Operation and Maintenance

Envistar Flex 060-1540

Home Concept FTX Flex 060-850



Order number:

Project name:



Unit specifications

Cooling unit ECO, ECX
 Reversible heat pump TCH
 Reversible heat pump TCR
 Home Concept configuration

Control equipment

MX
 US
 UC
 MK
 HS

Unit parts and accessories

Plate heat exchanger EXP
 Counter-flow exchanger EXM
 Rotary heat exchanger EXR
 Run-around coil unit EXL
 Air heater water EMT-VV, ELEV
 ThermoGuard ESET-TV, ELTV
 Air heater electric ESET-EV, ELEE
 Eff-var 1 2 3 4 5

Air cooler EMT-VK, ESET-VK, ELBC,
 ESET-DX, ELBD

Damper ESET-TR, EMT-01
 Intake section MIE-IU
 Exhaust air section EAU
 Recirculating unit EBE

Sound attenuator EMT-02, MIE-KL

Carbon filter section ECF

Filter bypass ENFT-10

Size

060	360	980
100	400	1080
150	480	1250
190	600	1280
240	740	1540
300	850	

Filter, supply air

Coarse-65% (G4)
 ePM10-60% (M5)
 ePM2,5-50%
 ePM1-50% (F7)
 ePM1-60% (F7)
 ePM1-70% (F8)
 ePM1-85% (F9)
 Carbon filter ePM1-70% (C7)
 Aluminium
 Excl. filter

Set of filters Black Ridge BR

Filter extract air

Coarse-65% (G4)
 ePM10-60% (M5)
 ePM2.5-50%
 ePM1-50% (F7)
 ePM1-60% (F7)
 ePM1-70% (F8)
 ePM1-85% (F9)
 Carbon filter ePM1-70% (C7)
 Aluminium
 Excl. filter



Table of Contents

1	Safety precautions	
1.1	Personal protective equipment	1
1.2	Prevent injury to personal or damage to air handling units	1
1.3	Product signs, information and warning stickers	2
1.4	Safety message	2
1.5	General safety messages	3
2	General	
2.1	Intended use	7
2.2	Unintended use	7
2.3	Manufacturer	7
2.4	Designations	7
2.5	CE marking (EU) and UKCA marking (UK)	8
2.6	Maintenance	8
2.7	Handling of refrigerant	8
2.8	Extended warranty	9
2.9	Spare parts	9
2.10	Dismantling and decommissioning	9
3	Technical description	
3.1	Envistar Flex air handling unit	10
4	Wiring instructions and fuse protection	
4.1	MX - Complete control equipment	
	Complete electrical connection to terminal without controller unit	11
4.2	MK – Fans and heat exchangers electrically connected to terminal	12
4.3	HS, US - Without control and without electrical connection	13
4.4	Wiring instructions, Fan (code ELFF)	14
4.5	Wiring instructions, Air Heater electric (code ESET-EV, ELEE*)	21
4.6	Wiring instructions, Rotary heat exchanger (code EXR/EXRD)	22

Table of Contents, cnt'd

5	Operation	
5.1	Hygiene inspection	23
5.2	Actions in case of standstill	23
5.3	Commissioning	24
6	Maintenance instructions	
6.1	Service schedule	25
6.2	Filters (code ELEF)	27
6.3	Rotary heat exchanger (code EXR)	31
6.4	Plate heat exchanger (code EXP, EXM)	36
6.5	Run-around coil unit (code EXL)	39
6.6	Air heater water (code EMT-VV, MIE-CL/ELEV)	42
6.7	Air heater electric (code ESET-EV, MIE-EL/ELEE)	44
6.8	Air cooler water (code EMT-VK, ESET-VK, ESET-DX, MIE-CL/ELBC, MIE-CL/ELBD)	46
6.9	Fan unit (code ELFF)	48
6.10	Damper (code ESET-TR, EMT-01)	52
6.11	Outdoor intake section with shut-off damper (code MIE-IU)	53
6.12	Outdoor exhaust air section with shut-off damper (code EAU)	54
6.13	Recirculating unit with shut-off/regulated damper (code EBE)	55
6.14	Sound attenuator (code EMT-02, MIE-KL)	56
6.15	Filter bypass (code ENFT-10)	57



1 Safety precautions

Follow all safety precautions in this document and pay attention to all warning signs on the air handling unit.

Failure to comply with the safety precautions may result in injury to persons or damage to air handling units.

1.1 Personal protective equipment

Personal protective equipment must always be used based on the risks present in the workplace.

The following personal protective equipment is recommended where the work requires:

- Protective shoes with steel cap
- Hearing protectors
- Safety helmet
- Gloves
- Goggles
- Covering clothing
- Protective overalls
- Mouthguard/protective mask
- Fall protection

1.2 Prevent injury to personal or damage to air handling units

To avoid injury to persons or damage to air handling units, pay attention to the following:





- Read the entire document before working on the unit.
- Comply with national and local laws and regulations for work safety.
- Do not wear loose clothing or jewellery that may get fasten.
- Do not step or climb on the unit.
- Use tools and equipment designed for your work.
- Use personal protective equipment when the work requires it.
- Observe the unit's product signs, information and warning stickers.
- Keep the unit clean and follow the Operation and Maintenance Instructions.
- Make sure that all covers are in place and that inspection hatches are closed before starting the unit.
- Lockable inspection hatches must be locked prior to starting the unit and after repairs/service.
- Use appropriate fall protection when working at heights - normally over 2 meters. Even work at lower heights may require protective measures.

1.3 Product signs, information and warning stickers

Keep signs and stickers free from soiling and replace them if they are lost, damaged or illegible. Contact IV Produkt for replacement stickers; specify the item number.

1.4 Safety message

The following warning symbols and signal words are used in this document to inform of risks.

	DANGER! Danger indicates an imminent dangerous situation which, if not avoided, can result in death or serious injury.
	WARNING! Warning indicates a potentially dangerous situation which, if not avoided, can lead to serious injury.
	CAUTION! Caution indicates a less potentially dangerous situation which, if not avoided, can lead to less serious or minor injuries.
	NB: NB: indicates a potentially hazardous situation which, if not avoided, may result in damage or impaired function of the air handling unit.

1.5 General safety messages

Comply with the following general safety messages.

Lockable safety switch

	<p>DANGER! Risk of serious injury. Electrical power can cause electric shock, burns and death.</p> <p>Working on/servicing the unit – Shut down the unit via the service switch in the control equipment, then turn the safety switch to the 0 position and lock it.</p> <p>There may be several safety switches serving the different parts of the unit. All safety switches must be switched off and locked before repairs/service.</p>
---	--

	<p>NB: The safety switch is not designed for starting/stopping the unit. Always use the service switch in the control equipment to start and shut down the unit.</p>
---	--

Electrical connections

	<p>DANGER! Risk of serious injury. Electrical power can cause electric shock, burns and death.</p> <p>Working on/servicing the unit – Shut down the unit via the service switch in the control equipment, then turn the safety switch to the 0 position and lock it.</p> <p>There may be several safety switches serving the different parts of the unit. All safety switches must be switched off and locked before repairs/service.</p>
---	--

	<p>WARNING! Risk of personal injury. Rotating fan impellers can cause crushing injuries or lacerations. The unit must not be energised until all ducts have been connected.</p>
---	---

	<p>NB: Wiring of connections and other electrical work may only be carried out by a qualified electrician or by service personnel recommended by IV Produkt.</p>
---	--

Lighting, option extra EMMT-07



DANGER!

Risk of serious injury.
 Electrical voltage can cause electric shock, burns and death.

When lighting (EMMT-07) is selected in the unit, this is fed externally and is not de-energized when the power on the unit's safety switch is cut.

Take the lighting wiring into account before repairs/service.

Inspection hatches



WARNING!

Risk of personal injury.
 Overpressure in unit.
 Allow the pressure to drop before you open the inspection doors.



WARNING!

Risk of personal injury.
 The doors in front of moving parts shall normally be locked; there are no contact guards.

During repairs/service, the inspection doors are locked with the supplied keys.

Make sure that all doors are in place, that inspection doors are closed and that lockable inspection doors are locked before starting the unit and after repairs/service.

Cooling unit/Reversible heat pump



WARNING!

Risk of personal injury.
 Hot surfaces can cause burns.

Working on/servicing the unit – Shut down the unit via the service switch in the control equipment, then turn the safety switch to the 0 position and lock it.

There may be several safety switches serving the different parts of the unit. All safety switches must be switched off and locked before repairs/service.

Wait at least 30 minutes before opening the compressor inspection hatches.

Heating coil



WARNING!
Risk of personal injury.
Hot surfaces can cause burns.

Working on/servicing the unit – Shut down the unit via the service switch in the control equipment, then turn the safety switch to the 0 position and lock it.

There may be several safety switches serving the different parts of the unit. All safety switches must be switched off and locked before repairs/service.

Wait at least 5 minutes before opening the battery inspection hatches.

Fan



WARNING!
Risk of personal injury.
Rotating fan impellers can cause crushing injuries or lacerations.

Working on/servicing the unit – Shut down the unit via the service switch in the control equipment, then turn the safety switch to the 0 position and lock it.

There may be several safety switches serving the different parts of the unit. All safety switches must be switched off and locked before repairs/service.

Wait at least 3 minutes before opening inspection hatches.

Rotary heat exchanger



WARNING!
Risk of personal injury.
Rotating thermal wheels can cause crushing injuries or lacerations.

Working on/servicing the unit – Shut down the unit via the service switch in the control equipment, then turn the safety switch to the 0 position and lock it.

There may be several safety switches serving the different parts of the unit. All safety switches must be switched off and locked before repairs/service.

Wait at least 3 minutes before opening inspection hatches.

Damper and damper motor



WARNING!

Risk of personal injury.

Moving parts can cause crushing injuries. Never place your hands near the damper motor or inside the damper when it closes.

Working on/servicing the unit – Shut down the unit via the service switch in the control equipment, then turn the safety switch to the 0 position and lock it.

There may be several safety switches serving the different parts of the unit. All safety switches must be switched off and locked before repairs/service.

Some dampers are closed via spring return in a de-energized state.

Wait at least 3 minutes for the damper to close.

Filter



WARNING!

Risk of personal injury – harmful dust.

Use a face mask/respiratory protection to avoid inhaling dust.

2 General

2.1 Intended use

The air handling units in the Envistar Flex series are designed for comfort ventilation in buildings.

When installed indoors, the unit must be positioned in an area that maintains a temperature between +7 and +30 °C, and with a moisture content of <3.5 g/kg in dry air in the winter. The unit can also be equipped for outdoor installation.

2.2 Unintended use

Any other use and setup in other environments are prohibited unless specifically permitted by IV Produkt AB.

It is not permitted to use the unit in potentially explosive environments, Eex.

2.3 Manufacturer

The Envistar air handling units (AHUs) are manufactured by:



IV Produkt AB
Sjöddevägen 7
SE-350 43 VÄXJÖ

2.4 Designations

Envistar Flex air handling units consist of a number of different block sections.

Each block section is supplied with a model identification label located on the inspection side.

The model identification label shows the order number and the required designations to identify the block part.

Ordernr / Order No / Tilaus nr / Nr zam / Auftragsnr.	
1234-56789	
Modell / Model / Malli / Model / Modell	
ENVISTAR FLEX	
Produktkod / Product code / Tuotekoodi / Kod produktu / Produktcode	
XXX-R-04-AA-2V-V-00	
Aggregatbeteckning / Project / Kohde / Agregat / Bezeichnung	
LA01	
Tillv.ort / Made in / Valmistettu / Produkcja / Herst.Ort	
VÄXJÖ, SWEDEN	
Tillv.m / Manuf.m. / Valmistus. k / Miesiav pr / Herst.Monat	
YYMM	
Art.nr. 19121-1001	

Typical model identification label

2.5 CE marking (EU) and UKCA marking (UK)



The air handling unit is CE and UKCA marked and meets the applicable requirements according to specified directives and standards in the Declaration of Conformity. The marking covers the assembly in the design in which it was delivered and provided that it has been assembled and commissioned in accordance with IV Produkt's instructions. The declaration does not cover assemblies that have been modified, components that have subsequently been added or other plants in which the assembly may be included. The unit may not be put into service until the system, in which it is a component, complies with the applicable requirements for CE and UKCA marking in the country where the unit is installed.

The Declaration of Conformity is available under Documentation at ivprodukt.docfactory.com or under Order Unique Documentation at docs.ivprodukt.com.

2.6 Maintenance

The ongoing maintenance of this unit can be carried out either by the person normally in charge of maintaining the building or through a contract with a well-reputed service company.

2.7 Handling of refrigerant

For refrigerant handling of cooling unit EcoCooler (code ECO, ECX) or reversible heat pump ThermoCooler HP (code TCH, TCR), refer to the separate Operation and Maintenance manual at docs.ivprodukt.com.

2.8 Extended warranty

In cases in which the equipment delivered is covered by a 5-year warranty, in accordance with ABM 07 with appendix ABM-V 07 or in accordance with NL 17 with appendix VU20, the IV Produkt Service and Warranty Manual is supplied with the product.

In order to claim an extended warranty, a complete, documented and signed IV Produkt Service and Warranty Manual must be presented.

2.9 Spare parts

Spare parts and accessories for this unit can be ordered from IV Produkt's nearest dealership. When ordering, the order number and designation must be given. These are stated on a model identification label, affixed to each functional section.

There is a separate spare parts list for the unit, refer to Order Unique Documentation at docs.ivprodukt.com.

2.10 Dismantling and decommissioning

When an air handling unit is to be dismantled, separate instructions must be followed, see [Dismantling and decommissioning the AHU](#) under Documentation at ivprodukt.docfactory.com.

3 Technical description

3.1 Envistar Flex air handling unit



The Envistar Flex is manufactured as a modular unit comprising block sections in various sizes. The versions are named according to the supply air and can be freely selected: right-hand or left-hand, up or down.

The units are equipped with either a rotary heat exchanger, counter-flow heat exchanger, plate heat exchanger or run-around coil unit.

The units are also available as single stacked supply air or extract air units in sizes 060-600. For more convenient transport, the unit can be delivered in block form in size 150-740.

The units can be supplied with or without integrated control equipment.

Cooling unit EcoCooler and reversible heat pump ThermoCooler HP are available as optional extras.

4 Wiring instructions and fuse protection

4.1 MX - Complete control equipment

Complete electrical connection to terminal without controller unit

- Code MX - unit supplied with process unit Siemens Climatix, fully connected and with complete integrated control equipment.
- Code UC - units supplied without controller unit but with sensor and damper actuator connected electrically to the terminal. Fans and heat exchangers are fused and connected electrically to the terminal. The terminal connections are positioned at a shared place in the unit. For further connection to an external process unit, we recommend using a multi-conductor cable.

Main switch

The main switch is located on the unit's control equipment.

Wiring diagrams

For wiring diagrams for units with control equipment, see the order-unique wiring diagram supplied with the unit at docs.ivprodukt.com (Control Diagram).

Unit functions, power supply and fuse protection

For power supply to the unit functions and recommended external fuse, refer to Order Unique Documentation at docs.ivprodukt.com (Technical Data and Control Diagram), or the product selection program IV Produkt Designer.

Recommended fuse protection refers to fuses with type C characteristics.



4.2 MK – Fans and heat exchangers electrically connected to terminal

Code MK - units supplied without control equipment but with fans and heat exchangers connected electrically to terminals.

Connections to terminal blocks are located on each unit section.

Safety switch

A safety switch must be fitted and wired on each power supply.

Wiring instructions and fuse protection

For wiring instructions and recommended fuses, refer to Order Unique Documentation at docs.ivprodukt.com (Terminal Connection and Technical Data).

Recommended fuse protection refers to fuses with type C characteristics.

4.3 HS, US - Without control and without electrical connection

- Code HS - for units without control equipment and without electrical connection, control diagrams are available for the heat exchanger (code EXM) under order-specific documentation at docs.ivprodukt.com, for other wiring instructions, refer to the following pages.
- Code US - for units without control equipment and without electrical connection, refer to the wiring instructions on the following pages.

Recommended fuse protection refers to fuses with type C characteristics.

Safety switch

A safety switch must be fitted and wired on each power supply.

Fan, power supply and fuse protection

The unit can be equipped with one to three fans on the supply air side and extract air side respectively.

For separate power supply of each fan, read and note the “Type” from the fan data plate.

NB: The fans may be different sizes/variants. Read both the supply air and extract air fan labels.

For the relevant power supply and recommended fuse protection, refer to docs.ivprodukt.com (Technical Data).

Fläkt / Fan / Puhallin Wentylator / Ventilator / Ventilateur			
Type	<input type="text"/>	-	r/m
	<input type="text"/> kW	<input type="text"/> A	<small>Uštekvens</small> <small>Out. frekvency</small> <small>Težusnauke</small> <small>Czeñstót. wyj.</small> <small>Ausg./frequen</small> <small>Z.</small> <small>Freq. sort</small> <small>Max. temp.</small>
	<input type="text"/> V		<input type="text"/> Hz
<small>K-faktor</small> <small>K-factor</small> <small>K-kerroin</small> <small>Wsp.K.</small> <small>K-faktor</small> <small>Facteur</small>	<input type="text"/>	$Q=1/K \times \sqrt{p}$	<input type="text"/> °C
Ref.			
ErP data			
Eff.degr.type	η total	N=	N=
Speed ctrl.			

Typical fan data label

4.4 Wiring instructions, Fan (code ELFF)

Ziehl EC 1x230 V
0,50 / 0,78 kW
fan impeller 025 / 028

Storlek 060-100

ELFF-025Z-EC01-0050

ELFF-025Z-ECA1-0050

ELFF-025Z-EC01-0078

ELFF-025Z-ECA1-0078

ELFF-028Z-EC01-0078

INKOPPLING / WIRING Ziehl 1x230 V - BD

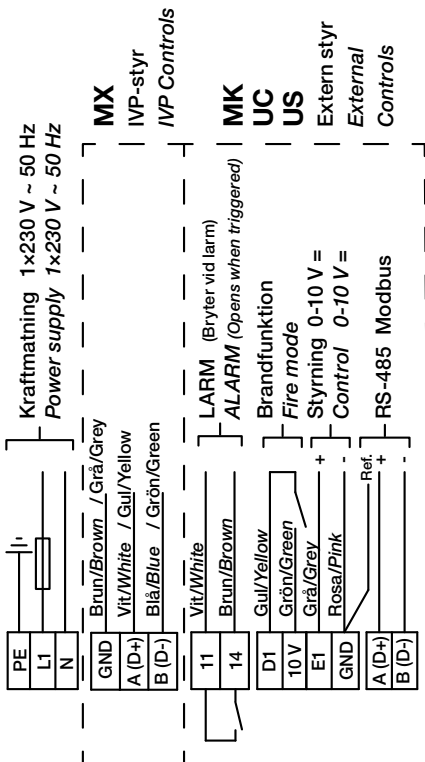

Art. Nr. 19151-0430_02

Ziehl EC 1x230 V
1,30 / 1,35 kW
fan impeller 031 / 035

Storlek 100-190

ELFF-031Z-EC02-0130

ELFF-035Z-EC02-0135

INKOPPLING / WIRING Ziehl 1x230 V - ZID.DC

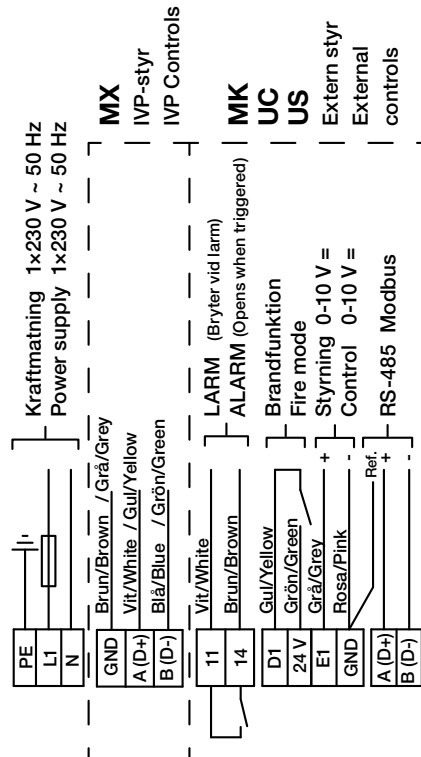

Art. Nr. 19151-0431_03

**Ziehl EC 3x400 V
 2,50 / 3,70 kW
 fan impeller 040**

Storlek 150-190

ELFF-040Z-EC02-0250

ELFF-040Z-EC02-0370

**INKOPPLING / WIRING
 Ziehl 3x400 V - DC, DG**

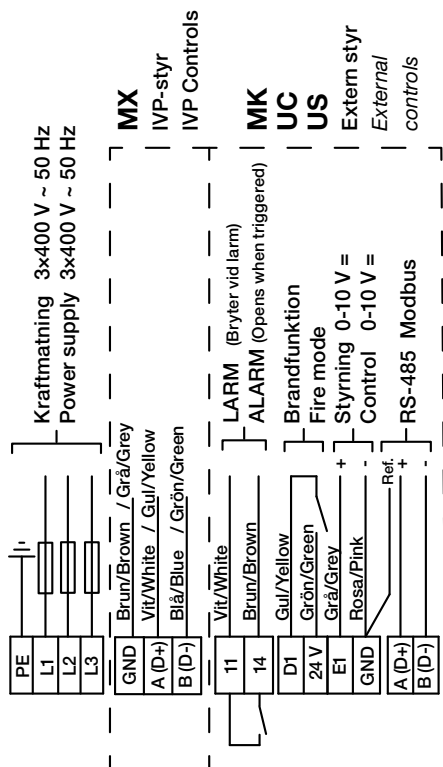

Art. Nr. 19151-0432_02

**Ziehl EC 3x400 V
 1,70 kW
 fan impeller 045**

Storlek 240-300

ELFF-045Z-EC02-0170

**INKOPPLING / WIRING
 Ziehl 3x400 V - DC, DG**

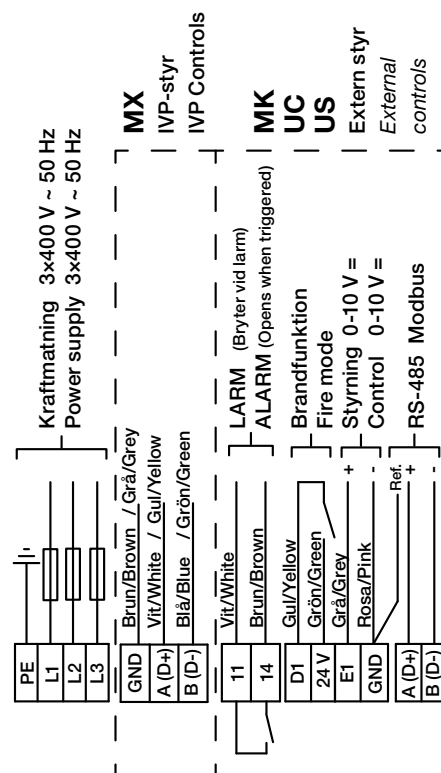

Art. Nr. 19151-0432_02

**Ziehl EC 3x400 V
 3,50 / 4,80 kW
 fan impeller 050**

Storlek 240-600

ELFF-050Z-EC02-0350

ELFF-050Z-EC02-0480

**INKOPPLING / WIRING
 Ziehl 3x400 V - DC, DG**

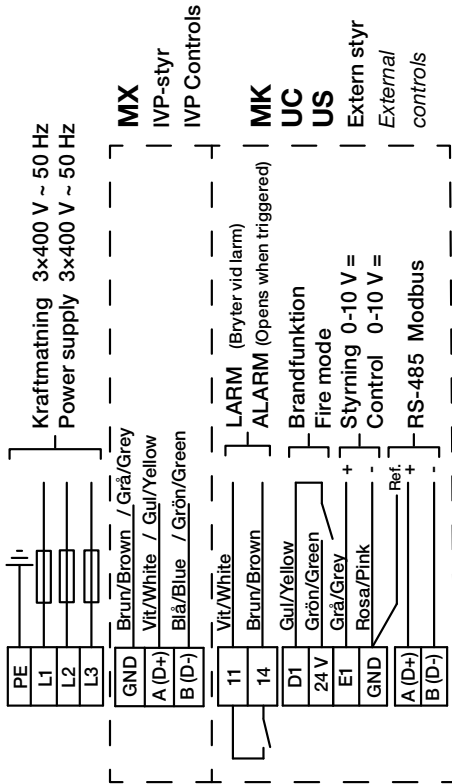

Art. Nr. 19151-0432_02

**Ziehl EC 3x400 V
 3,40 / 5,20 kW
 fan impeller 056**

Storlek 360-740

ELFF-056Z-EC02-0340

ELFF-056Z-EC02-0520

ELFF-056Z-ECA2-0340

ELFF-056Z-ECA2-0520

**INKOPPLING / WIRING
 Ziehl 3x400 V - DC, DG**

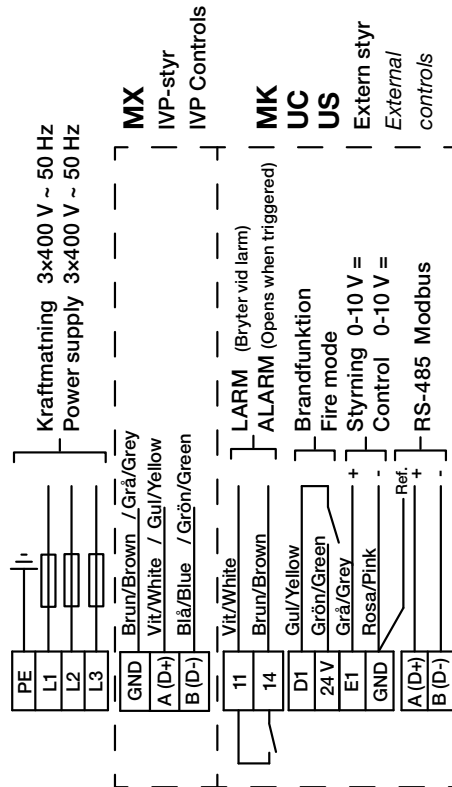

Art. Nr. 19151-0432_02

Ziehl EC dual fans
2 x 3x400 V
2,50 / 3,70 kW
fan impeller 2 x 040 / 45

Storlek 360-600

ELFF-040Z-EC02-0250

ELFF-040Z-EC02-0370

ELFF-040Z-ECA2-0370

INKOPPLING FLERA FLÄKTAR / WIRING SEVERAL FANS
ZIEHL 3x400 V - DC, DG, GG

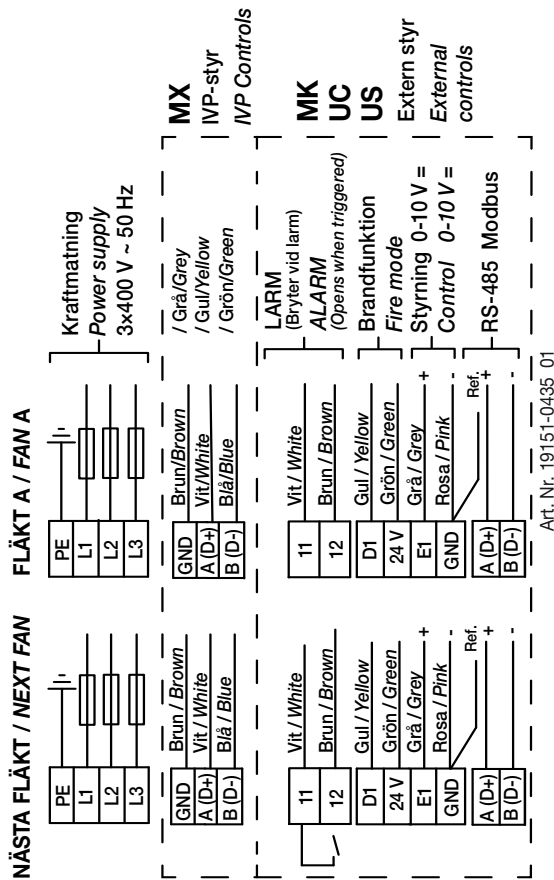

Ziehl EC dual fans
2 x 3x400 V
3,50 / 4,80 kW
fan impeller 2 x 50

Storlek 480-980

ELFF-050Z-EC02-0350

ELFF-050Z-EC02-0480

INKOPPLING FLERA FLÄKTAR / WIRING SEVERAL FANS
ZIEHL 3x400 V - DC, DG, GG

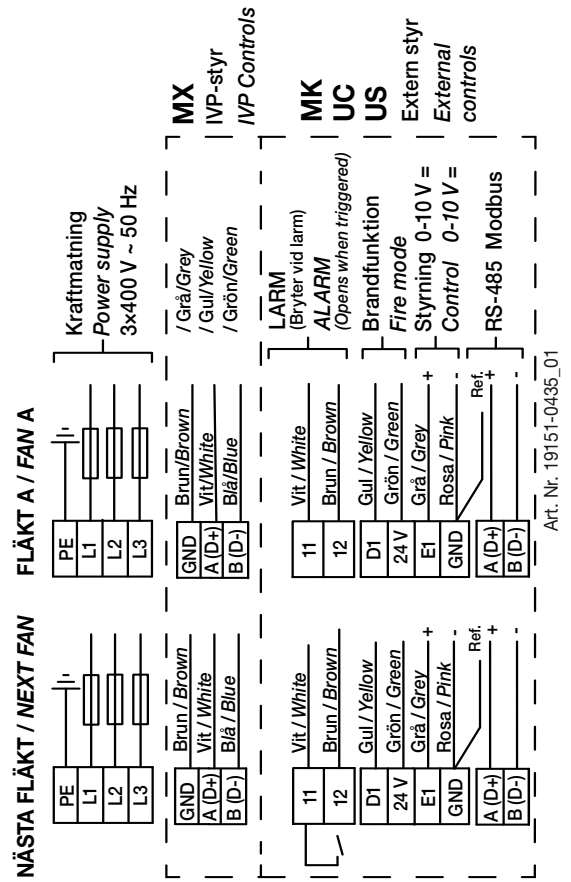

Ziehl EC dual fans
2 x 3x400 V
3,40 / 5,20 kW
fan impeller 2 x 056

Storlek 600-980, 1080, 1280

ELFF-056Z-EC02-0340

ELFF-056Z-ECA2-0340

ELFF-056Z-EC02-0520

ELFF-056Z-ECA2-0520

INKOPPLING FLERA FLÄKTAR / WIRING SEVERAL FANS
ZIEHL 3x400 V - DC, DG, GG

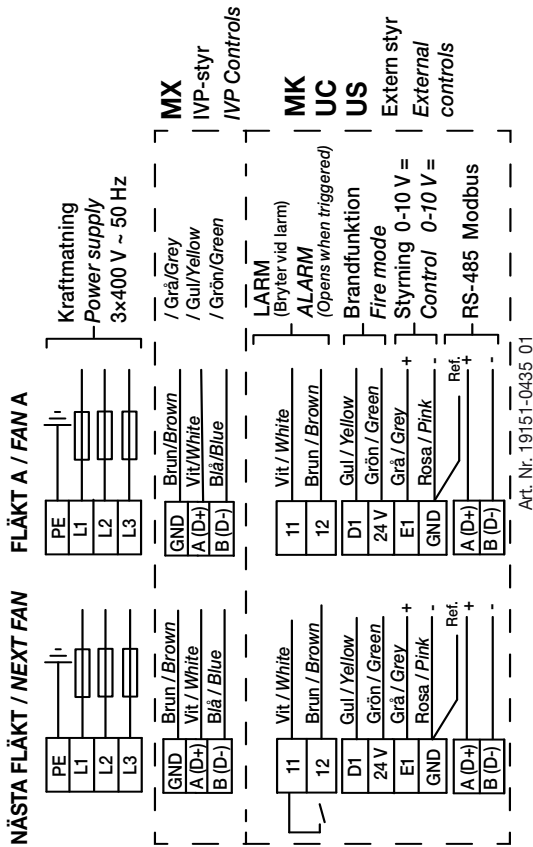

Ziehl EC triple fans
3 x 3x400V
3,40 / 5,20 kW
fan impeller 3 x 056

Storlek 1080, 1280

ELFF-056Z-EC02-0340

ELFF-056Z-ECA2-0340

ELFF-056Z-EC02-0520

ELFF-056Z-ECA2-0520

INKOPPLING FLERA FLÄKTAR / WIRING SEVERAL FANS
ZIEHL 3x400 V - DC, DG, GG

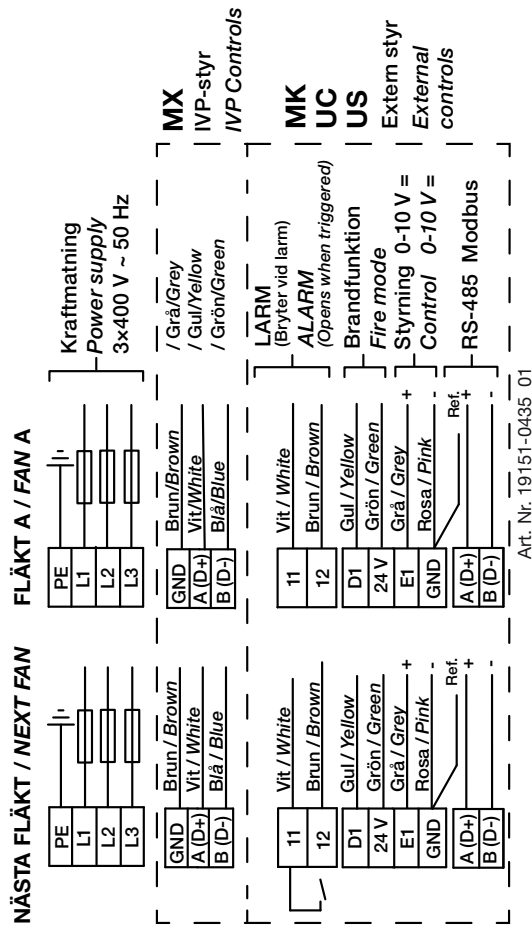

**EBM EC 3x400 V
 1,74-5,70 kW
 fan impeller 045-056**

Storlek 450-740

ELFF-045E-EC01-0174

ELFF-050E-EC01-0345

ELFF-050E-EC01-0570

ELFF-056E-EC01-0330

ELFF-056E-ECA2-0330

ELFF-056E-EC01-0500

ELFF-056E-ECA2-0500

**INKOPPLING / WIRING
 EBM 3x400 V - P8, M3, M5**

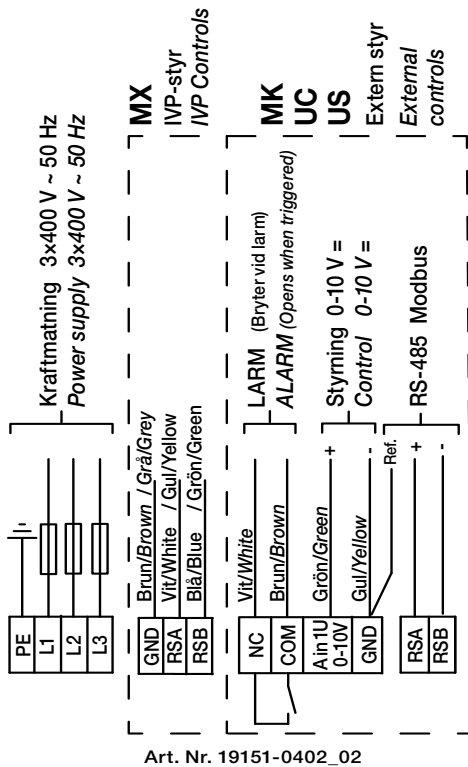

**EBM EC dual fans
 2 x 3x400 V
 1,74-5,7 kW
 fan impeller 2 x 045-056**

Storlek 400-980

ELFF-045E-EC01-0174

ELFF-045E-EC01-0290

ELFF-050E-EC01-0345

ELFF-050E-EC01-0570

ELFF-056E-EC01-0330

ELFF-056E-ECA2-0330

ELFF-056E-EC01-0500

ELFF-056E-ECA2-0500

**INKOPPLING DUBBELFLÄKT / WIRING DOUBLE FAN
 2xEBM 3x400 V - M3, M5**

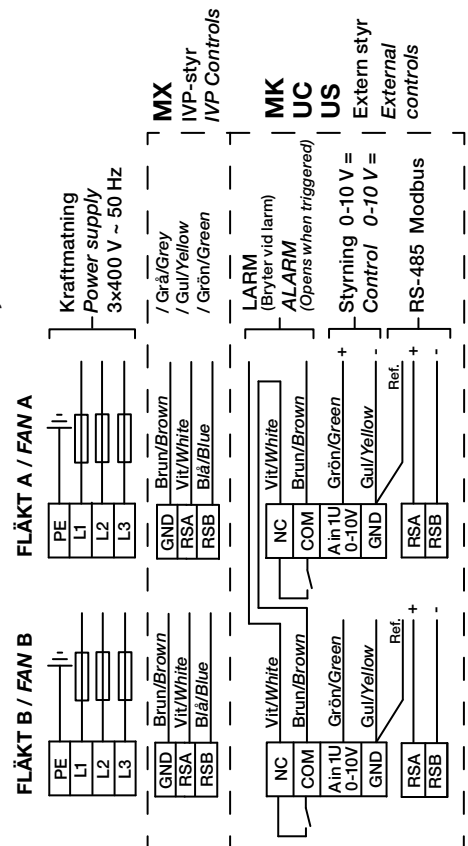

**DOMEL PFJ1 3x400 V
 4,3-6,5 kW
 fan impeller 063-071**

Storlek 480-980

ELFF-063G-PFJ1-0430

ELFF-063G-PFJ1-0650

ELFF-071G-PFJ1-0650

**INKOPPLING / WIRING
 OJ-DV 3x400 V**

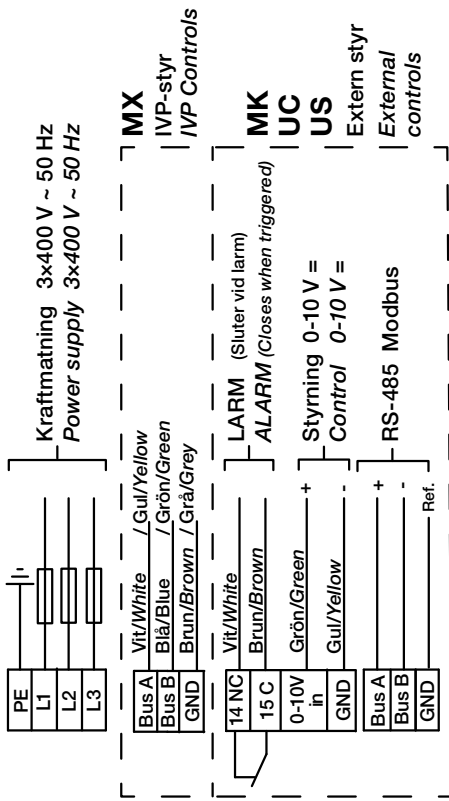

Art. Nr. 19151-0480_01

**DOMEL PFJ1 dual fans
 2 x 3x400 V
 4,3-6,5 kW
 fan impeller 2 x 063-071**

Storlek 740-1540

ELFF-063G-PFJ1-0430

ELFF-063G-PFJ1-0650

ELFF-071G-PFJ1-0650

**INKOPPLING DUBBELFLÄKT / WIRING DOUBLE FAN
 2xOJ-DV 3x400 V**

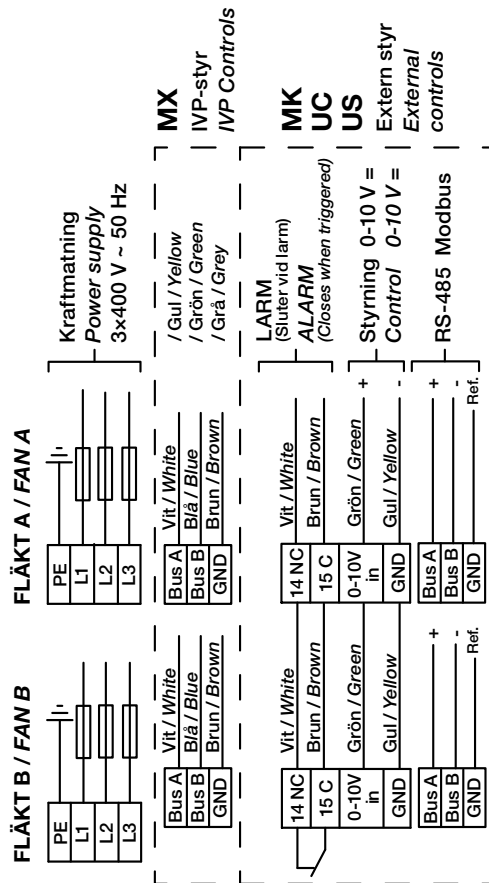

Art. Nr. 19151-0490_01

4.5 Wiring instructions, Air Heater electric (code ESET-EV, ELEE*)

For power supply, refer to order-specific documentation at docs.ivprodukt.com (Technical Data).

*With integrated control equipment (code ELEE-xxx-HS)

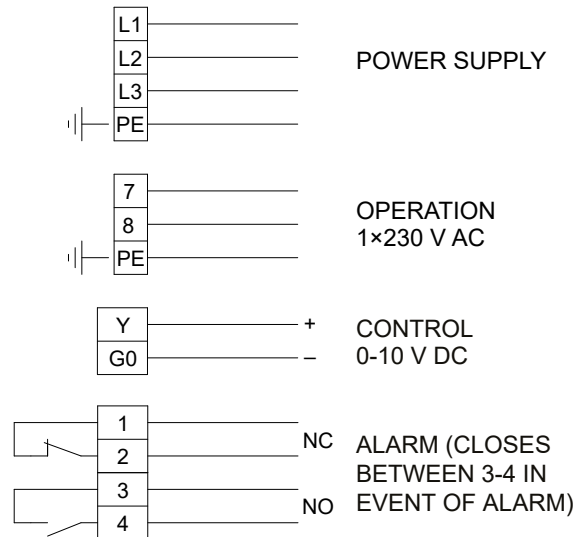



4.6 Wiring instructions, Rotary heat exchanger (code EXR/EXRD)

Size 060-980 OJ Electronics

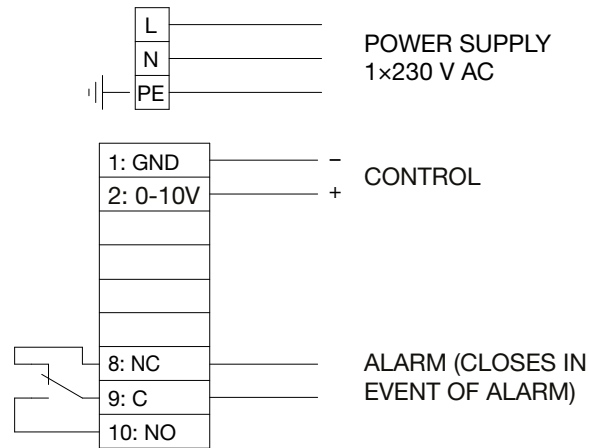

Size 1080-1540 OJ Electronics

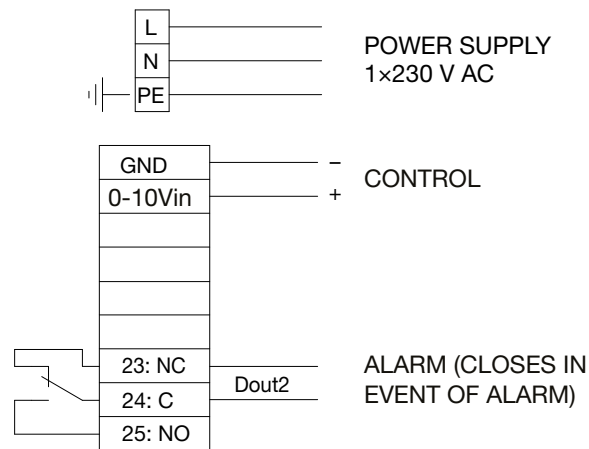

5 Operation

5.1 Hygiene inspection

Envistar Flex conforms to guidelines in VDI 6022 Part 1: Hygiene and Hygiene Inspections of HVAC Systems.

For this to apply, a hygiene inspection of the system must be carried out and the system must be cleaned thoroughly as needed before start-up.

For units, code MK, US,UC:

	<p>NB: Pressure surges on filters and air ducts must be prevented through the design of the duct system and the settings/ configuration of the control system (for example, gradual start of fans and open damper when the fans are in operation).</p>
---	--

5.2 Actions in case of standstill

According to guidelines for hygienic design VDI 6022 Part 1:

In case of prolonged standstill in air treatment systems (more than 48 hours), it should be ensured that no moist areas can be found downstream of the cooling coils or humidifier.

In order to avoid the accumulation of moisture – turn off the cooling coils and humidifier in good time and ventilate the air ducts dry (gradual shut-down). Also, be sure to set up or program the required functions in the building's automation/ control system for automatic dry blowing of air coolers and downstream sections.

5.3 Commissioning

Commissioning the unit must be carried out by qualified personnel in accordance with the Commissioning Record, which can be downloaded at docs.ivprodukt.com or ivprodukt.docfactory.com.

The Commissioning Record applies to units that are supplied with control equipment (code MX).

The validity of the product warranty is conditional on the system having been correctly commissioned. Working on the unit during the warranty period without the approval of IV Produkt shall render the warranty void.

Prior to commissioning, the contractor must:

	<p>DANGER! Risk of serious personal injury and/or damage to air handling unit. Read and understand the entire chapter "1.5 General safety messages" before working on, servicing, or inspecting the air handling unit.</p>
---	---

1. Connect the unit to the power supply via a lockable safety switch.
2. Connect the heating/cooling coil.
3. Connect all ducts.



6 Maintenance instructions

6.1 Service schedule

The service schedule comprises actions and service intervals for functional sections that can be part of the air handling unit. For current parts, refer to docs.ivprodukt.com (Technical data).





Make copies of the service schedule for future use before you fill in servicing data for the first time.

For hygiene inspections according to guideline VDI 6022, see separate [VDI 6022 Checklist for Operation and Maintenance, Hygiene checks](https://ivprodukt.docfactory.com) at ivprodukt.docfactory.com.

Service year 20		Order no.		Project name			
Comments				Service performed * (date and signature)			
Functional section	Code	Recommended action (insp.)	Page ref.	12 mths	24 mths	36 mths	48 mths
 Filter supply air, extract air	ELEF	Check pressure drop Change filter if necessary	27	signature	signature	signature	signature
 Rotary heat exchanger	EXR	Visual inspection Check press. balance Check diff. pressure Control rotor speed Clean if necessary	31	signature	signature	signature	signature
 Counter-flow/ Plate heat exchanger	EXM/EXP	Visual inspection Clean if necessary Check function	36	signature	signature	signature	signature
 Run-around coil unit	EXL	Visual inspection Check drainage Clean if necessary Check function	39	signature	signature	signature	signature
 Air heater water	EMT-VV, MIE-CL/ELEV, ESET-TV, MIE-CL/ELTV	Visual inspection Clean if necessary Check function	42	signature	signature	signature	signature
 Air heater electric	ESET-EV, MIE-EL/ELEE	Visual inspection Clean if necessary Check function	44	signature	signature	signature	signature
 Air cooler water/DX	ESET-VK, MIE-CL/ELBC, MIE-CL/ELBD	Visual inspection Check drainage Clean if necessary Check function	46	signature	signature	signature	signature
 Fan unit	ELFF	Visual inspection Clean if necessary Check the air flow	48	signature	signature	signature	signature
 Damper	EMT-01, ESET-TR	Visual inspection Clean if necessary Check tightness	52	signature	signature	signature	signature
 Outdoor intake section with damper	MIE-IU	Visual inspection Clean if necessary Check tightness	52	signature	signature	signature	signature



*More frequent servicing may be required in certain environments. Replace the filter if the pressure drop across the filter exceeds the specified final pressure drop.

cont. Service schedule

Service year 20		Order no.		Project name			
Comments				Service performed * (date and signature)			
Functional section	Code	Recommended action (insp.)	Page ref.	12 mths	24 mths	36 mths	48 mths
 Outdoor exhaust air section with damper	EAU	Visual inspection Clean if necessary Check tightness	54	signature	signature	signature	signature
 Recirculating unit section with damper	EBE	Visual inspection Clean if necessary Check tightness	55	signature	signature	signature	signature
 Sound attenuator	EMT-02, MIE-KL	Visual inspection Clean if necessary	56	signature	signature	signature	signature
 Reversible heat pump	TCH, TCR	Refer to separate Operation and Main- tenance Instructions	–	signature	signature	signature	signature
 Cooling unit, EcoCooler	ECO, ECX	Refer to separate Operation and Main- tenance Instructions	–	signature	signature	signature	signature

*More frequent servicing may be required in certain environments.

Home Concept model

Service year 20		Order no.		Project name			
Comments				Service performed * (date and signature)			
Functional section	Code	Recommended action (insp.)	Page ref.	12 mths	24 mths	36 mths	48 mths
 Carbon filter in filter cabinet	ELCF	Inspection indication Replace if necessary	28	signature	signature	signature	signature
 Filter bypass	ENFT-10	Visual inspection Clean if necessary Check tightness	57	signature	signature	signature	signature

*More frequent servicing may be required in certain environments.

6.2 Filters (code ELEF)

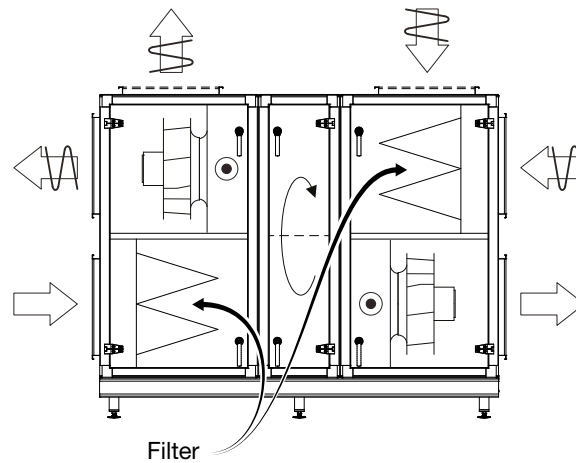

The air filters in an air handling unit are designed to prevent dust and other impurities from entering the building. They should also protect sensitive components inside the unit, e.g. water coils and heat exchangers, from exposure to impurities.

The dust separation efficiency varies considerably between various filter types. The dust collecting efficiency also varies substantially. It is therefore important to use filters of the same quality and capacity when you change them.

According to guidelines for hygienic design VDI 6022 Part 1: The supply air filter must be class ePM1-50% (F7) or have a higher filtration efficiency.

The filters are designed for one-time use. If they become fouled, the unit will lose capacity. The filters should therefore be changed if the pressure drop across them exceeds the specified final pressure drop. It is important to stop the unit before changing filters to prevent dust from coming loose and being drawn into the unit. The inside surfaces of the filter sections must therefore also be cleaned when the filters are changed.

Filter for Home Concept configuration (code ECF)

The filter cabinet is an optional extra for the Home Concept version and can be used for

- aluminium filter on the extract air side
- carbon filter on the supply air side

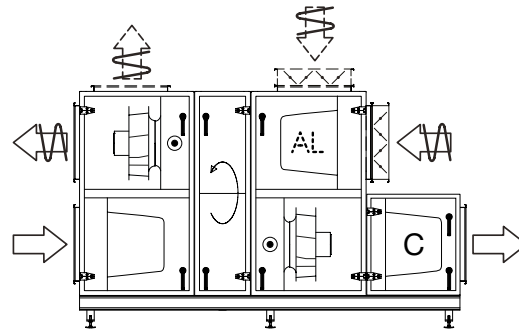

AL - aluminium filter, C - carbon filter, Black Ridge

The aluminium filter is intended for use where the extract air contains grease particles to avoid grease being sucked into the unit. The filter is a knitted flat-type filter. The aluminium filter can be cleaned using hot water and a mild detergent.

The carbon filter (code ELCF) can be used in rotary units (rotary heat exchanger) to remove odours in the form of organic and odorous gases/vapours. The carbon filters are fitted to the supply air side.

The carbon filters are Black Ridge filters, constructed as compact and highly efficient, molecular filters. The filters are designed for one-time use and the filter is combustible in its entirety.

Lifespan and filter control Carbon filter

The function and lifespan of the carbon filters depends on the volume of air that passes through and on the molecular density of odorous substances. This means that the time intervals for filter replacement can vary from unit to unit depending on operation mode and the volume of odorous substances in the air.

Units delivered with control equipment (code MX) are equipped with the filter control function – FLC (Filter Lifetime Control). FLC indicates when it is time to replace the carbon filter. Indication is through an alarm on the hand-held terminal display.

FLC calculates the volume of air passing through the carbon filters and triggers the alarm for filter replacement when the preset value has been reached. The value for air passing through is specified in mega cubic metres (Mm³). The function does not take into account the odour content of the air, which means that the indication should be regarded as a recommendation for checking the filter function. If no odours pass through, there is no need to replace the filter.

Preset FLC values, as per the table below, are based on max. air flow over 12 months of full-time operation. If required, the value can be lowered in order to: - change to more frequent filter replacement intervals for max. air flow - retain the filter replacement interval of 12 months for lower air flows.

To change the value, see separate Climatix control documentation.

Inspection



DANGER!
 Risk of serious personal injury and/or damage to air handling unit.
 Read and understand the entire chapter "1.5 General safety messages" before working on, servicing, or inspecting the air handling unit.

Check the pressure drops across the filters (not carbon filter Black Ridge in Home Concept version). Pressure drops are measured with a pressure gauge connected to the measurement outlets. The measurement outlets are connected to each side of the filter.

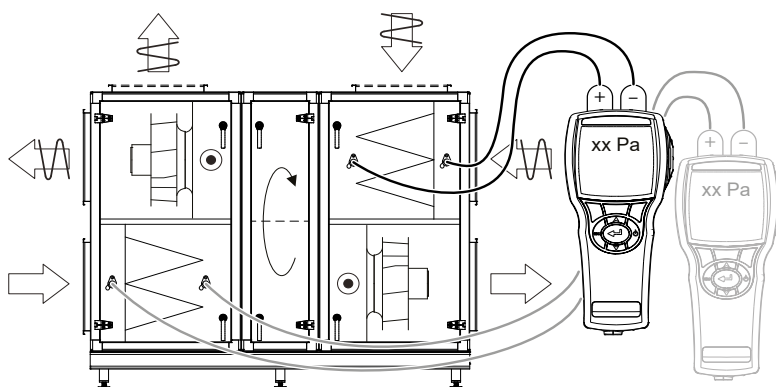

If the filter has reached its specified final pressure drop, it should be changed. The final pressure drop is specified on the filter section decal (filled in when the air handling unit is put into operation). Also carry out a visual inspection of the filter for damage and deposits.

FILTERDATA

Nominellt luftflöde m³/s
 Nominal air flow..... m³/h
 Antal filter Mått
 Number of filters..... Dimensions.....

 Filterklass/Filter Class.....
 Begynnelsestryckfall
 Initial Pressure Drop.....Pa
 Sluttryckfall
 Final Pressure Drop.....Pa

Art. Nr: 19121-1101_02SV

Filter data

For filter data, refer to [Filter Overview](#) under Documentation at ivprodukt.docfactory.com. Actual filters are shown in the unit specification in this document and under Order Unique Documentation at docs.ivprodukt.com (Technical Data and Spare Parts List).

Filter replacement

**DANGER!**

Risk of serious personal injury and/or damage to air handling unit.

Read and understand the entire chapter "1.5 General safety messages" before working on, servicing, or inspecting the air handling unit.

1. Shut down the unit via the service switch in the control equipment, safety switch in the 0 position.
2. Wait until the fans have stopped, then open the inspection door.
3. Release the eccentric rails.

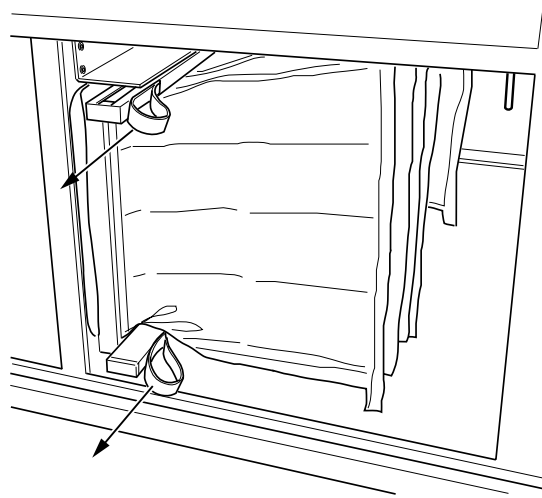

Example eccentric rails

4. Remove the old filter by pulling it towards you. Discarded filters should be disposed of correctly. The carbon filters are combustible in their entirety.
5. Clean the filter cabinets.
6. Install the new filter, press in the eccentric rails to engage them and close the inspection door.
7. Reset the FLC filter control function via the Climatix display, refer to separate Climatix control documentation. (Only applicable to the Home Concept configuration of the unit with carbon filter and control equipment (code MX).)
8. Start the unit.

6.3 Rotary heat exchanger (code EXR)

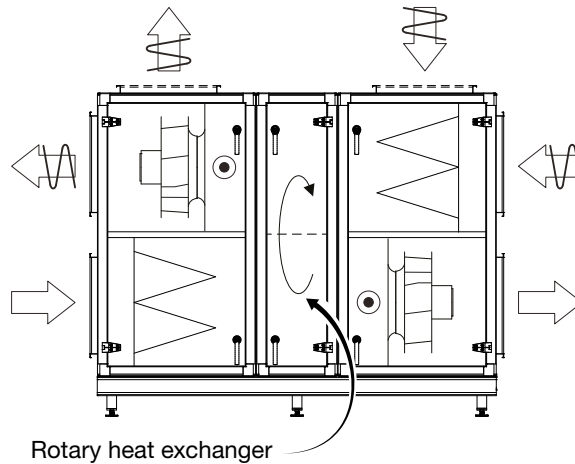

The purpose of the recovery unit is to recover heat from the extract air and transfer this heat to the supply air in order to minimise energy use.

Faults in recovery unit functionality result in reduced heat recovery efficiency and increased energy use and means that the design supply air temperature cannot be obtained when the outdoor temperature is low.

A conceivable reason for reduced recovery efficiency may be that the thermal wheel rotates too slowly because the drive belt is slipping. The rotor speed should not be lower than 8 rpm during full energy recovery.

It is not usual for the rotor passages to become fouled with dust, since the rotor is normally self-cleaning. However, this might occur if the dust is of a sticky nature.

A reduction of the extract air flow, for example, due to fouling of the extract air filter, entails reduced heat recovery efficiency.

Units in the Home Concept design are equipped with a function to control the pressure balance of the thermal wheel to ensure the correct leakage function and purging function. For units supplied with control equipment, the function is connected and activated at the factory. For units without control equipment, this function must be connected to the unit.

Inspection

	<p>DANGER! Risk of serious personal injury and/or damage to air handling unit. Read and understand the entire chapter "1.5 General safety messages" before working on, servicing, or inspecting the air handling unit.</p>
---	---

1. Shut down the unit via the service switch in the control equipment, safety switch in the 0 position.
2. Wait until the fans have stopped, then open the inspection door.
3. Check that the rotor rotates easily. If it is sluggish, you might have to adjust the bristled sealing strip.
4. Check that the rotor's bristled sealing strip seals against the side plates and that it is not worn. The bristled sealing strip is subject to wear and can be adjusted or replaced if the need arises.
5. Check that the drive belt is properly tensioned and does not slip. If it slips, it will have to be shortened. The rotor speed should not be lower than 8 rpm during full energy recovery.
6. Check that the drive belt is intact and clean.
7. Check that the rotor's inlet surfaces are not covered with dust or other impurities. NB: Avoid touching the rotor inlet and outlet surfaces with your hands or tools.
8. Check the pressure balance:

For the Home Concept configuration, the trim damper ESET/TR regulates the pressure balance automatically against the set value in the controller unit. Check that the measured pressure balance between measurement tapings P2 and P3 corresponds to the set pressure balance setpoint in the controller unit (-10 Pa).

Example:

Measurement outlets for P2: Downstream supply air fan (SF) generates negative pressure in relation to the atmospheric pressure (atm), for example, -100 Pa.

Measurement outlets for P3: Downstream extract air fan (EF) and trim damper generate greater negative pressure than at P2, for example, -110 Pa.

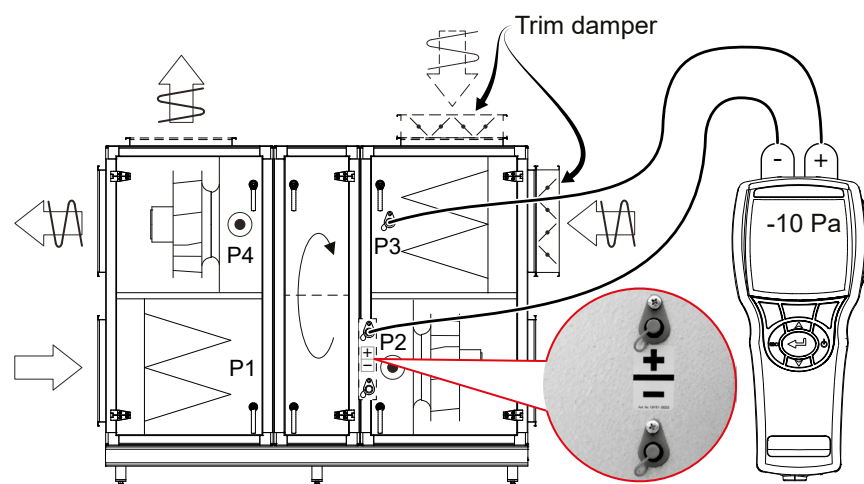

For the standard version: To ensure correct function of the purging sector, the negative pressure at P3 should be greater than the negative pressure at P2 (min. diff. 25 Pa). Otherwise an ESET-TR trim damper can be used on the extract air side in order to throttle in the correct pressure balance.

Example:

Measurement outlets for P2: Downstream supply air fan (SF) generates negative pressure in relation to the atmospheric pressure (atm), for example, -100 Pa.

Measurement outlets for P3: Downstream extract air fan (EF) and any trim damper generate greater negative pressure than at P2, for example, -125 Pa.

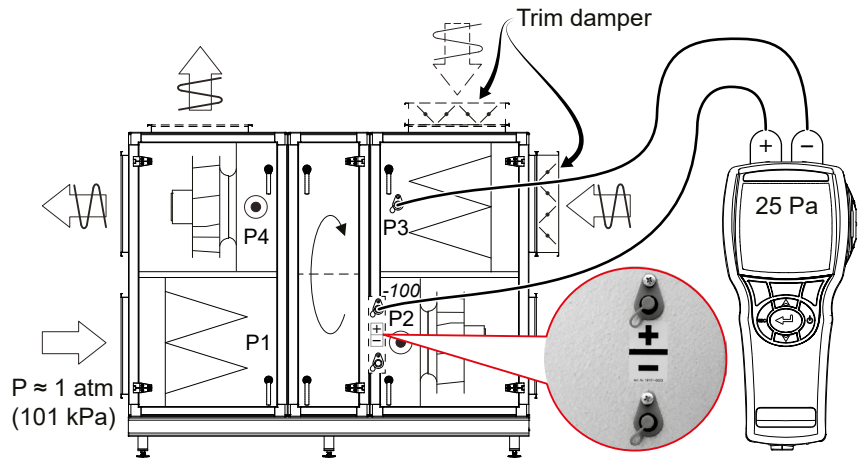

9. Check the differential pressure across the rotor. The purging sector is factory-installed, set to the maximum open position. Depending on the unit's pressure difference across the rotor, the purging sector may need adjustment. An incorrect setting may impair the efficiency. Inspection and adjustment should be carried out as follows:

- Measure and write down the differential pressure between the outdoor air (P1) and the extract air (P3).

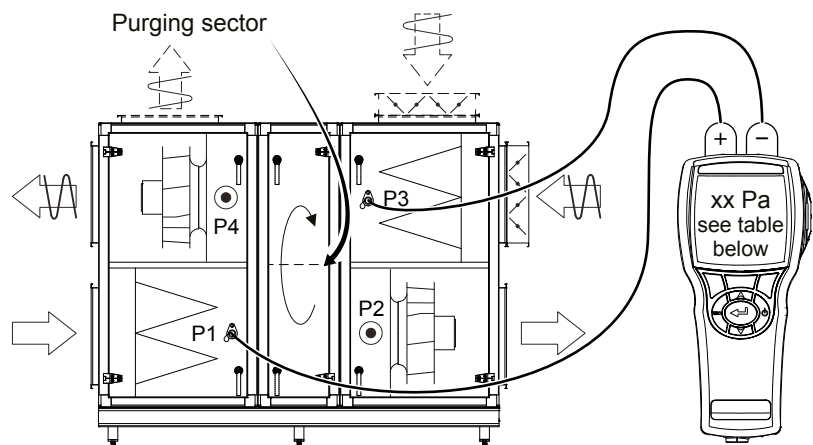

- Read the recommended setting (adjustment hole in the purging sector) from the table below.

	Thermal wheel variant	Adjustment hole in the purging sector				
		5 open*	4	3	2	1 closed
Diff. pressure between P1 and P3 (Pa)	R20, R30, R40, NO, NE, HY, HE, EX	< 200	200 – 400	400 – 600	> 600	–
	R50, R60, NP, NX, HP	< 300	300 – 500	500 – 700	> 700	–

**maximum open purging sector, preset mode from the factory*

- Adjust the purging sector if the need arises. The illustration shows the purging sector set to the maximum open position.

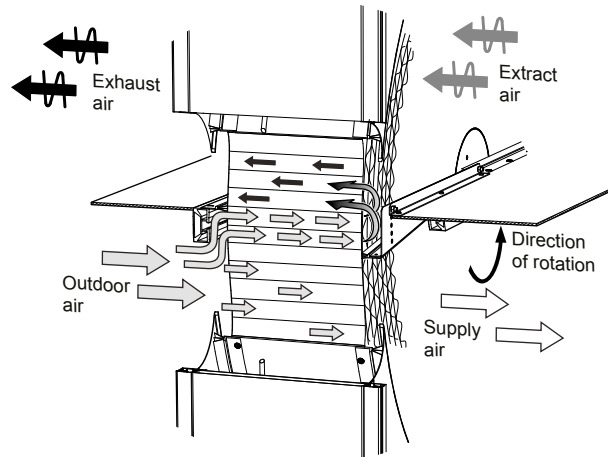

Schematic diagram - sizes and model may vary

Cleaning



DANGER!

Risk of serious personal injury and/or damage to air handling unit.

Read and understand the entire chapter "1.5 General safety messages" before working on, servicing, or inspecting the air handling unit.

- Remove dust by carefully vacuum cleaning using a soft brush.
- If the thermal wheel surfaces are severely fouled by greasy dust, spray the rotor with water mixed with a dishwashing detergent that will not corrode aluminium. Alternatively, detergents intended for heat exchangers, such as Re-Coilex (see below) are used.
- Compressed air at low pressure (max. 6 bar) can be used for blowing the surfaces clean. To avoid damage, the nozzle should not be held any closer to the rotor than 5–10 mm.

A hygroscopic rotor variant can absorb particles which in some cases give off odours. To prevent odours arising, exercise run the hygroscopic rotor using the integrated control function. If an odour persists, we recommend cleaning the thermal wheel with a mild, alkaline detergent.

For cleaning it is recommended that the purge sector is fully open and the rotational speed is 8 rpm as this assists with the suction of the detergent. Post-rinsing is not normally required.

Lubrication

The bearings and drive motor are permanently lubricated and do not require additional lubrication.

6.4 Plate heat exchanger (code EXP, EXM)

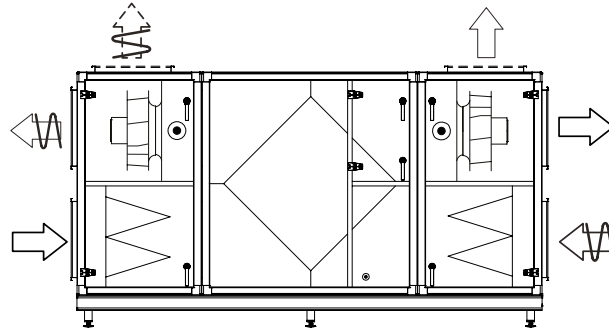

Crossflow plate heat exchanger, EXP

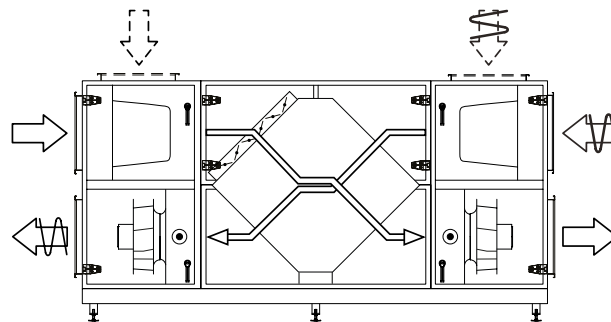

Counter-flow plate heat exchanger, EXM

The purpose of the plate heat exchanger is to recover heat from the extract air and transfer this heat to the supply air in order to minimise energy use.

Faults in plate heat exchanger functionality result in reduced heat recovery efficiency and increased energy use and means that the design supply air temperature cannot be obtained when the outdoor temperature is low.

Possible reasons for reduced recovery efficiency could be the fouling of the heat-exchanging surfaces (fins) or that the bypass damper is not closing completely.

A reduction of the extract air flow, for example, due to fouling of the extract air filter, entails reduced heat recovery efficiency.

If operation problems arise due to ice build-up on the extract air side, the function of the frost protection equipment should be checked.

Inspection



DANGER!
 Risk of serious personal injury and/or damage to air handling unit.
 Read and understand the entire chapter "1.5 General safety messages" before working on, servicing, or inspecting the air handling unit.

1. Shut down the unit via the service switch in the control equipment, safety switch in the 0 position.
2. Wait until the fans have stopped, then open the inspection hatch.
3. Inspect the fins for fouling.
4. Perform a visual inspection of the dampers and damper motors on frost protection equipment.
5. Check that the bypass damper is tightly shut when defrosting is not taking place.
6. Check the waste outlet and water trap function. A water trap without a non-return valve should be filled with water.

Cleaning



DANGER!
 Risk of serious personal injury and/or damage to air handling unit.
 Read and understand the entire chapter "1.5 General safety messages" before working on, servicing, or inspecting the air handling unit.

The plate heat exchanger is designed to prevent dirt and deposits from coming into contact with the heat transfer surfaces. Most of the particles in the air simply pass through the plate heat exchanger. The main risk for fouling of the counter-flow exchanger comes from slow-moving substances that condense on the surfaces, and also from fibres from tumble dryers, for example.

The recommended way to clean the plate heat exchanger is by vacuuming, compressed air blowing, and flushing with hot water (if necessary, add some mild detergent that is not corrosive to aluminium). Also clean the drip tray, bottom plate, drain and water trap.



NB:
 High pressure flushing must not be directed at the fins. Be careful in order to ensure that the fins do not become deformed or break.

At operating temperatures below 0 °C, the plate heat exchanger must be dry before commissioning.

Functional description, defrost and bypass function (ODS) (EXMM-XP/NP)

Under certain operating conditions, frost and ice may build-up on the extract air side of the plate heat exchanger. In order to optimise heat recovery, there is a built-in defrost function. This is based on the principle that the defrost function is engaged when the pressure drop over the extract air side of the counter-flow exchange exceeds a certain value.

Defrosting takes place through the regulation of dampers on the outdoor air side of the counter-flow exchanger. The dampers have separate damper motors that are controlled by a defrost program. Damper control means that there are a number of different combinations of damper positions, for instance that one of the dampers can be partly open while another is closed and the third damper is fully open.

During full heat recovery, the dampers must be fully open and the bypass damper must be closed.

When the unit is switched off, all dampers must be closed.

When there is a risk of frost, the dampers can be in different positions.

The defrost and bypass function is preset at the factory and any adjustments must be performed by IV Produkt.

Functional Description Frosting function (BYP) (EXMM-NP, EXPP-NO/NP/XP)

Under certain operating conditions, frost and ice may build-up on the extract air side of the plate heat exchanger. In order to optimise heat recovery, and avoid freezing, there is a built-in frosting function. The principle is based on the frosting function starting when the temperature of the exhaust air side's coldest surface falls below a certain value.

The freezing process is prevented by reducing heat recovery gradually through regulating dampers on the heat exchanger's outdoor air side. The dampers for the extract air/exhaust air temperature close and the bypass damper opens. In this way, the extract air temperature is increased and freezing is avoided.

During full heat recovery and when the unit is switched off, the dampers should be fully open (bypass damper closed).

The frosting and bypass functions are preset at the factory and any adjustments may only be performed by IV Produkt.

6.5 Run-around coil unit (code EXL)

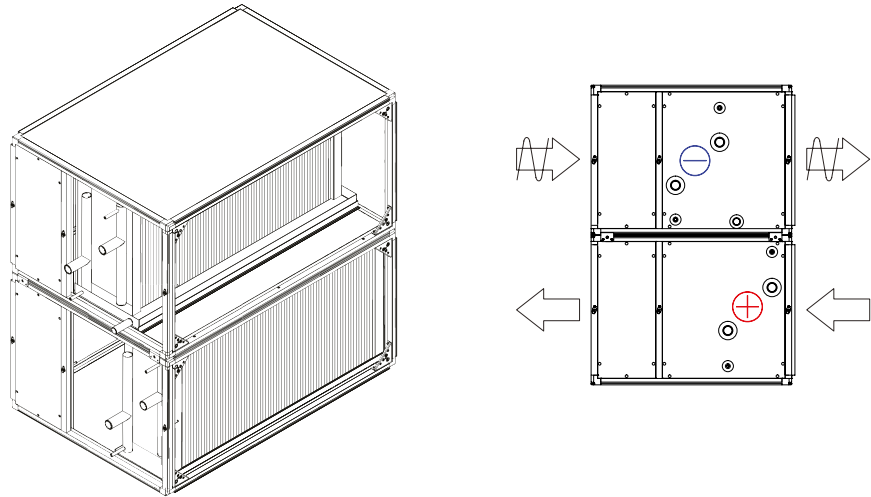

The run-around coil unit is used to recover heat from the extract air and transfer this heat to the supply air for reduced energy use. The run-around coil unit consists of the extract air coil with drip tray and the supply air coil (heating coil) mounted in the casing.

Moisture precipitation in the extract air's heat recovery coil entails a risk of freezing and possibly frost/ice forming. This freezing is counteracted by installing and connecting a freezing sensor that controls the valve actuator (liquid flow) in the extract air coil.

The coils will have impaired capacity if dust forms a coating on the coil surfaces. Not only does this impair the heat transfer capacity of the coil, it also increases the pressure drop on the air side. Even if the ventilation system is fitted with high quality filters, as time passes dust deposits will form on the front edges of the coil fins (at the inlet side). To utilise its full capacity, the coils must be well vented. The pipework should be vented by opening the bleeder screws in pipe connections and/or an air vessel.

Inspection

	<p>DANGER! Risk of serious personal injury and/or damage to air handling unit. Read and understand the entire chapter "1.5 General safety messages" before working on, servicing, or inspecting the air handling unit.</p>
---	---

Check:

1. The coil fins to detect possible mechanical deformity
2. That the coils are not leaking
3. The drip tray and drain with water trap (clean if necessary)
4. That the water trap (without non-return valve) is filled with water
5. That the pressure in expansion vessels (in the bellows/membrane of the expansion vessel) in pressure-relieved systems is at the same pressure as during installation. If necessary, fill the expansion vessel's bellows/membrane with compressed air to the correct pressure
6. That the system pressure, which is read on the pressure gauge in the pipe circuit (normally located at expansion vessels), maintains the same pressure as during installation. If necessary, fill the system with the intended liquid to the correct system pressure.

Cleaning

	<p>DANGER! Risk of serious personal injury and/or damage to air handling unit. Read and understand the entire chapter "1.5 General safety messages" before working on, servicing, or inspecting the air handling unit.</p>
---	---

If the fins on the coils are dirty, vacuum them from the inlet side. Alternatively, you can blow them clean with compressed air from the outlet side. If they are particularly dirty, clean them with hot water mixed with dishwashing detergent (that will not corrode aluminium).

Bleeding



DANGER!
 Risk of serious personal injury and/or damage to air handling unit.
 Read and understand the entire chapter "1.5 General safety messages" before working on, servicing, or inspecting the air handling unit.

Bleed the heating coil and the pipework if needed. Bleeder screws are on top of the coils or on the pipe connections.

Function



DANGER!
 Risk of serious personal injury and/or damage to air handling unit.
 Read and understand the entire chapter "1.5 General safety messages" before working on, servicing, or inspecting the air handling unit.

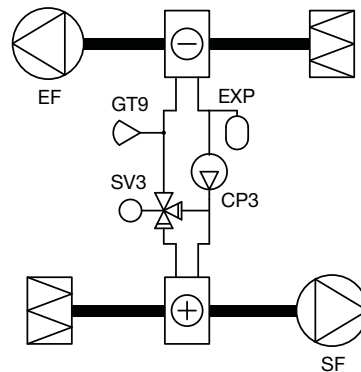

- SF Supply air fan
- EF Extract air fan
- CP3 Circulation pump energy recovery circuit
- SV3 Valve actuator energy recovery circuit
- GT9 Freezing sensor

Check that the circulation pump is running in the correct direction and that the valve changes to opening/closing when the setpoints/conditions are changed.

6.6 Air heater water (code EMT-VV, MIE-CL/ELEV)

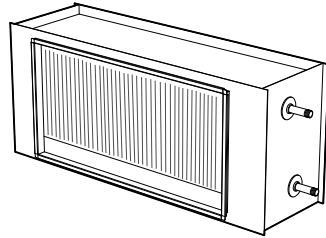

Air heater water (code EMT-VV)

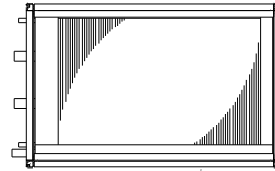

Air heater water (code MIE-CL/ELEV)

The heating coil consists of a number of copper tubes with aluminium fins pressed on them. The coil will have impaired capacity if dust forms a coating on the coil surfaces. Not only does this impair the heat transfer capacity of the coil, it also increases the pressure drop on the air side.

Even if the ventilation system is fitted with high quality filters, as time passes dust deposits will form on the front edges of the coil fins (at the inlet side). To utilise its full capacity, the coil must be well vented. The pipework should be vented by opening the bleeder screws in pipe connections and/or an air vessel.

Inspection

	<p>DANGER! Risk of serious personal injury and/or damage to air handling unit. Read and understand the entire chapter "1.5 General safety messages" before working on, servicing, or inspecting the air handling unit.</p>
---	---

Check:

1. The coil fins to detect possible mechanical deformity
2. That the water coil is not leaking.

Cleaning

	<p>DANGER! Risk of serious personal injury and/or damage to air handling unit. Read and understand the entire chapter "1.5 General safety messages" before working on, servicing, or inspecting the air handling unit.</p>
---	---

If the fins on the coil are dirty, vacuum clean from the inlet side. Alternatively, you can blow them clean with compressed air from the outlet side. If they are severely fouled, you can clean them with warm water mixed with dishwashing detergent that will not corrode aluminium.

Bleeding

	<p>DANGER! Risk of serious personal injury and/or damage to air handling unit. Read and understand the entire chapter "1.5 General safety messages" before working on, servicing, or inspecting the air handling unit.</p>
---	---

Bleed the heating coil and the pipework if needed. Bleeder screws are on top of the coil or on the tube connections.

Function

	<p>DANGER! Risk of serious personal injury and/or damage to air handling unit. Read and understand the entire chapter "1.5 General safety messages" before working on, servicing, or inspecting the air handling unit.</p>
---	---

Check that the coil is radiating heat. This can be done by temporarily increasing the temperature setting (setpoint).

Additional maintenance for ThermoGuard (code ESET-TV, MIE-CL/ELTV)

	<p>DANGER! Risk of serious personal injury and/or damage to air handling unit. Read and understand the entire chapter "1.5 General safety messages" before working on, servicing, or inspecting the air handling unit.</p>
---	---

1. The ThermoGuard coil must be fitted with a safety valve, the function of which should be checked regularly (at least once a year). If you see that the valve is leaking, this is normally due to impurities from the pipe system that have accumulated on the valve seat.
 In normal cases, it is sufficient to carefully turn the valve knob and in this way "flush" the valve seat clean. If the safety valve continues to leak, you will have to replace it with a new one of the same type and with the same opening pressure.
2. Any shut-off valves on the supply or return lines may not be closed if freezing temperatures are likely.
3. If a Thermoguard coil has frozen, let it thaw completely before restarting operation. If the heat recovery unit is installed upstream of the coil, it is often sufficient to run heat recovery to thaw the coil. If this does not work, some other external heating source will have to be used for thawing the water coil.

	<p>NB! To ensure correct ThermoGuard coil function, the entire coil must be allowed to thaw before returning it to full operation. Make sure that water is circulating in the entire coil when you start it up.</p>
---	--

6.7 Air heater electric (code ESET-EV, MIE-EL/ELEE)

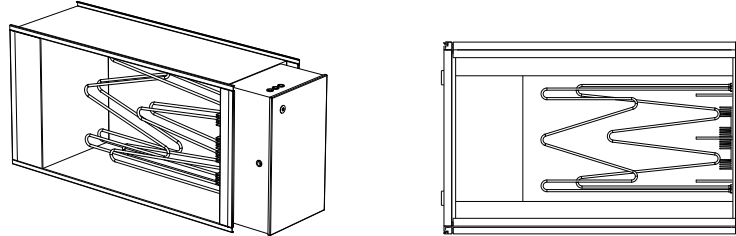

Air heater electric (code ESET-EV) and air heater electric (code MIE-EL/ELEE)

The electric heater consists of encapsulated stainless steel smooth pipe elements. Heavy soiling on the heating elements may cause the temperature to get too hot. This can shorten their service life. This might also entail an odour of burnt dust and, in the worse case, the risk of fire. Overheated elements may become deformed or loosen from their suspended brackets and heat the air unevenly.

Inspection

	<p>DANGER! Risk of serious personal injury and/or damage to air handling unit. Read and understand the entire chapter "1.5 General safety messages" before working on, servicing, or inspecting the air handling unit.</p>
---	---

Check that the elements are correctly positioned and that they are not deformed in any way.

Cleaning

	<p>DANGER! Risk of serious personal injury and/or damage to air handling unit. Read and understand the entire chapter "1.5 General safety messages" before working on, servicing, or inspecting the air handling unit.</p>
---	---

Vacuum or wipe surfaces with a moist cloth to remove any dust or impurities.

Function



DANGER!

Risk of serious personal injury and/or damage to air handling unit.

Read and understand the entire chapter "1.5 General safety messages" before working on, servicing, or inspecting the air handling unit.

1. Simulate reduced required output by temporarily lowering the temperature setting (setpoint), so that all the electric output steps (contactors) switch out.
2. Then sharply increase the setpoint setting and check that the electrical steps switch in.
3. Restore the temperature setting.
4. Stop the air handling unit (NB: Do not break the circuit with the safety switch). All the electric output steps should switch out (i.e. the contactors in the OFF position). Stopping the unit may be delayed approx. 2–5 minutes to allow the fans to cool the heat energy stored in the air heater.

The electric heater is equipped with dual temperature limiters. The one that resets itself automatically should be set to 70°C.

The overheat protection with manual reset interrupts operation when the heater reaches approx. 120°C and is located on the cover panel on the side of the heater. **Determine the cause of overheating and take corrective action before you reset the protection device.**

Please note that the risk of overheating increases as the air flow through the unit decreases. The air speed should not be lower than 1.5 m/s.

6.8 Air cooler water (code EMT-VK, ESET-VK, ESET-DX, MIE-CL/ELBC, MIE-CL/ELBD)

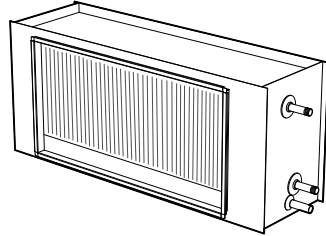

Air cooler (code ESET-VK, ESET-DX)

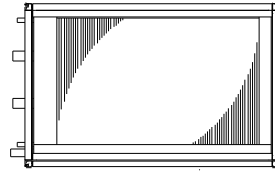

Air cooler (code MIE-CL/ELBC, MIE-CL/ELBD)

The cooling coil consists of a number of copper tubes with aluminium fins pressed onto them. The coil will have impaired capacity if dust forms a coating on the coil surfaces.

Not only does this impair the heat transfer capacity of the coil, it also increases the pressure drop on the air side.

Even if the ventilation system is fitted with high quality filters, as time passes dust deposits will form on the front edges of the coil fins (at the inlet side). A drip tray with drain is located under the cooling coil for collecting and removing condensation water, and in some cases there is a droplet eliminator downstream of the cooling coil which prevents drops of water accompanying the air stream.

Inspection

	<p>DANGER! Risk of serious personal injury and/or damage to air handling unit. Read and understand the entire chapter "1.5 General safety messages" before working on, servicing, or inspecting the air handling unit.</p>
---	---

Check:

1. The coil fins to detect possible mechanical deformity
2. That the water coil is not leaking
3. That cooling energy is uniformly distributed across the coil surfaces (in operation)
4. The drip tray and drain with water trap (clean if necessary)
5. That the water trap without non-return valve is filled with water.

Cleaning



DANGER!

Risk of serious personal injury and/or damage to air handling unit.

Read and understand the entire chapter "1.5 General safety messages" before working on, servicing, or inspecting the air handling unit.

If the fins on the coil are dirty, vacuum clean from the inlet side. Alternatively, you can blow them clean with compressed air from the outlet side. If they are severely fouled, you can clean them with warm water mixed with dishwashing detergent that will not corrode aluminium. For more information, refer to [Cooling coil, cleaning](#) under Documentation at ivprodukt.docfactory.com.

Bleeding (NB: ESET-VK and MIE-CL/ELBC only)



DANGER!

Risk of serious personal injury and/or damage to air handling unit.

Read and understand the entire chapter "1.5 General safety messages" before working on, servicing, or inspecting the air handling unit.

Bleed the water coil and the pipework if needed. Bleeder screws are on top of the coil or on the tube connections.

Function



DANGER!

Risk of serious personal injury and/or damage to air handling unit.

Read and understand the entire chapter "1.5 General safety messages" before working on, servicing, or inspecting the air handling unit.

Check that the coil is emitting cooling energy. This can be done by temporarily lowering the temperature setting (setpoint). Note that cooling is blocked when the outdoor temperature drops below the set value for cooling start.

6.9 Fan unit (code ELFF)

The purpose of the fans is to transport air through the system, i.e. the fan must overcome the flow resistance in air terminals, air ducts and the unit.

The fan speed is regulated to provide correct air flow. If the fans generate a lower air flow, this will impair the function of the ventilation system.

- If the supply air flow is too low, the system will be out of balance, causing poor room climate.
- If the extract air flow is too low, the ventilation capacity will be unsatisfactory. Imbalance may also force moist air out into the building structure. One reason why the fans are generating too little air flow may be that impurities have collected on the fan impeller blades.
- If a centrifugal fan is rotating in the wrong direction, the air flow will still go the right way, but with a considerable reduction in capacity. Therefore check the direction of rotation.

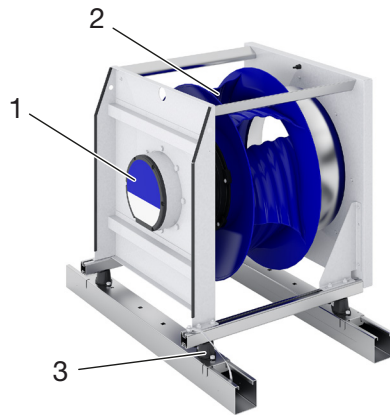

Example fan size 060-1080, 1280

1. EC motor with control unit
2. Fan impeller
3. Vibration damper

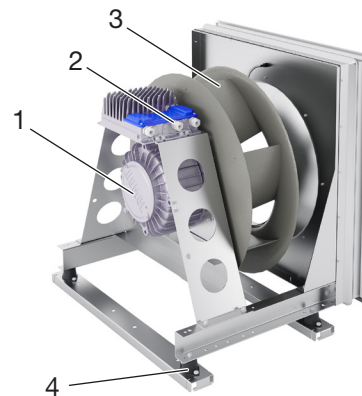

Example, fan size 480-1540

1. Motor
2. Control unit
3. Fan impeller
4. Vibration damper

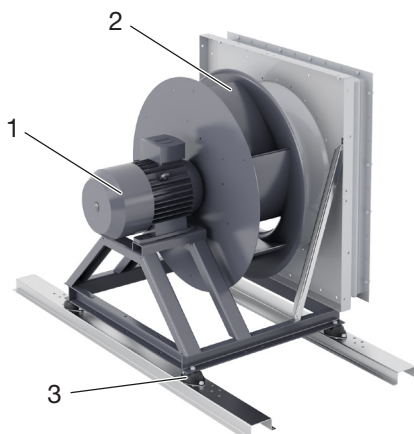

Example, fan size 1540

1. Motor
2. Fan impeller
3. Anti-vibration mounting

Inspection



DANGER!
 Risk of serious personal injury and/or damage to air handling unit.
 Read and understand the entire chapter "1.5 General safety messages" before working on, servicing, or inspecting the air handling unit.

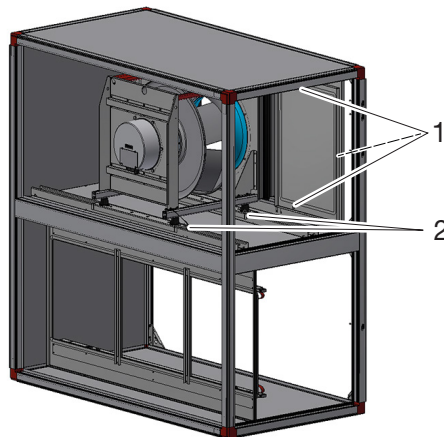

Example, fan unit

1. Screw
 2. Pin/screw

1. Prepare access:

Size 060–400:

The fans are mounted on rails. Remove one end of the fan assembly's earth braid. Loosen the screws (position 1) and the pins/screws (position 2) and pull out the fan units (fan and motor are mounted on rails).

Size 480-1540:

The fans are permanently mounted to rails. Access normally occurs through the inspection door/doors. Fans mounted on rails can be pulled out if necessary. Remove one end of the fan assembly's earth braid. Loosen the screws (position 1) and the pins/screws (position 2) and pull out the fan units. NB: For multiple fans, the screws securing all plates must be loosened.

2. Check that the fan impeller rotates easily, rotates in the right direction, is in balance and does not vibrate. Also check that the fan impeller is clean from any accumulation of particles. Imbalance may be due to a coating or damage to the fan impeller blades.
3. Listen to the sound from the motor bearings. If the bearings are in good condition, you will hear a slight purring sound. A scraping or pounding sound may mean that the bearings are damaged and service is then required.
4. Check that the fan impellers are firmly mounted and that they overlap the inlet cones.

5. The fan impeller and motor are mounted on a support fitted with rubber anti-vibration mountings. Check that the anti-vibration mountings are securely mounted and are intact.
6. Check the mounting screws as well as the suspension devices and support.
7. Check that the gaskets on the connection plates around the connection openings are intact and firmly fitted.
8. Check that the measurement tubes are securely fitted on each measurement outlet.
9. Remount the fan units.
10. Check the air flows by:
 - reading the flow display on the Climatix display unit for units with control equipment (code MX).
 - measuring Δp in the connections (measurement outlets) for flow measurement +/- for units without control equipment (code UC, MK, US).

Use the unit's flow sign and see which flow corresponds to the measured Δp .

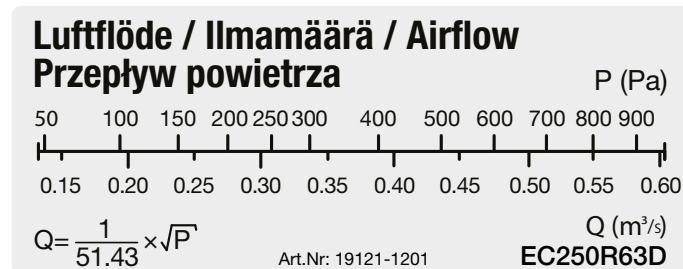

Example of flow sign

Cleaning



DANGER!

Risk of serious personal injury and/or damage to air handling unit.

Read and understand the entire chapter "1.5 General safety messages" before working on, servicing, or inspecting the air handling unit.

1. Follow items 1-7 under *Inspection*.
2. Wipe the fan impeller blades to remove any coatings. Use an environmentally friendly degreasing agent.
3. The external surfaces of the motor must be kept clean from dust, dirt and oil. Clean with a dry cloth. In the event of heavy soiling, use an environmentally friendly degreasing agent. The motor is likely to overheat inside if thick layers of dirt prevent air from entering the motor to cool the stator structure.
4. Vacuum clean the air handling unit so that particles will not be blown out into the duct system.
5. Clean the other parts in the same way as the fan impellers. Check that the inlet cones are securely mounted.
6. Remount the fan units.

Resetting the overheat protection (For ELFF with code -EC01-, -EC02-, -ECA2-)



DANGER!

Risk of serious personal injury and/or damage to air handling unit.

Read and understand the entire chapter "1.5 General safety messages" before working on, servicing, or inspecting the air handling unit.

1. Cut the power supply to the fan motor.
2. Wait at least 20 seconds after the fan impeller has stopped rotating.
3. Close the power supply to the fan motor.

6.10 Damper (code ESET-TR, EMT-01)

Dampers may have different functions and be positioned in different places.

- EMT-01 shut-off/ regulated damper
- ESET-TR trim damper with manual control

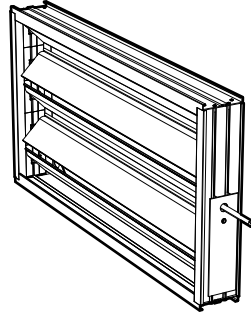

The purpose of the dampers is to regulate the air flow. Faulty function gives rise to disturbances that may result in serious problems.

- If the damper does not open fully, the air flow is reduced.
- If the damper leaks, this will result in increased energy use.
- If the trim damper for the rotor purging function is not working or is incorrectly set, it may result in odours from the extract air being transferred to the supply air via the rotor.
- If the damper is placed on the outdoor air side and does not close completely when the unit stops, the heating coil may freeze.

Inspection

	<p>DANGER! Risk of serious personal injury and/or damage to air handling unit. Read and understand the entire chapter "1.5 General safety messages" before working on, servicing, or inspecting the air handling unit.</p>
---	---

1. Check the function of the damper actuator.
2. Check the dampers for tightness when they are closed. If they are not sealed, adjust the damper actuator to make the dampers tight (does not apply to trim dampers).
3. Check the sealing strips.
4. If the damper is not working, check that there are no screws penetrating the drive mechanism/damper blades to interfere with damper function.

Cleaning

	<p>DANGER! Risk of serious personal injury and/or damage to air handling unit. Read and understand the entire chapter "1.5 General safety messages" before working on, servicing, or inspecting the air handling unit.</p>
---	---

Clean the damper blades with a cloth. In the event of heavy soiling, an environmentally friendly degreasing agent can be used.

6.11 Outdoor intake section with shut-off damper (code MIE-IU)

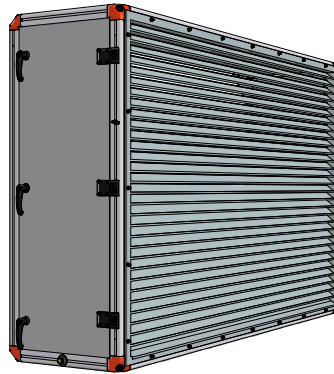

Outdoor intake section with shut-off damper is equipped with intake louvre and drainage.

Inspection



DANGER!
 Risk of serious personal injury and/or damage to air handling unit.
 Read and understand the entire chapter "1.5 General safety messages" before working on, servicing, or inspecting the air handling unit.

1. Check the function of the damper actuator.
2. Check the dampers for tightness when they are closed. If they are not sealed, adjust the damper actuator to make the damper tight.
3. Check the sealing strips.
4. If the damper is not working, check that there are no screws penetrating the drive mechanism/damper blades to interfere with damper function.
5. Check the function of the drainage.

Cleaning



DANGER!
 Risk of serious personal injury and/or damage to air handling unit.
 Read and understand the entire chapter "1.5 General safety messages" before working on, servicing, or inspecting the air handling unit.

Clean the damper blades with a cloth. In the event of heavy soiling, an environmentally friendly degreasing agent can be used.

6.12 Outdoor exhaust air section with shut-off damper (code EAU)



Outdoor exhaust air section is used to reduce the risk of short-circuiting between outdoor air and exhaust air.

Inspection

	<p>DANGER! Risk of serious personal injury and/or damage to air handling unit. Read and understand the entire chapter "1.5 General safety messages" before working on, servicing, or inspecting the air handling unit.</p>
---	---

1. Check the function of the damper actuator.
2. Check the dampers for tightness when they are closed. If they are not sealed, adjust the damper actuator to make the damper tight.
3. Check the sealing strips.
4. If the damper is not working, check that there are no screws penetrating the drive mechanism/damper blades to interfere with damper function.

Cleaning

	<p>DANGER! Risk of serious personal injury and/or damage to air handling unit. Read and understand the entire chapter "1.5 General safety messages" before working on, servicing, or inspecting the air handling unit.</p>
---	---

Clean the damper blades with a cloth. In the event of heavy soiling, an environmentally friendly degreasing agent can be used.

6.13 Recirculating unit with shut-off/regulated damper (code EBE)



The recirculating unit with shut-off/regulated damper is used to, for example, recirculate air in conjunction with heating of the premises at night.

Inspection



DANGER!
 Risk of serious personal injury and/or damage to air handling unit.
 Read and understand the entire chapter "1.5 General safety messages" before working on, servicing, or inspecting the air handling unit.

1. Check the function of the damper actuator.
2. Check the dampers for tightness when they are closed. If they are not sealed, adjust the damper actuator to make the damper tight.
3. Check the sealing strips.
4. If the damper is not working, check that there are no screws penetrating the drive mechanism/damper blades to interfere with damper function.

Cleaning



DANGER!
 Risk of serious personal injury and/or damage to air handling unit.
 Read and understand the entire chapter "1.5 General safety messages" before working on, servicing, or inspecting the air handling unit.

Clean the damper blades with a cloth. In the event of heavy soiling, an environmentally friendly degreasing agent can be used.

6.14 Sound attenuator (code EMT-02, MIE-KL)

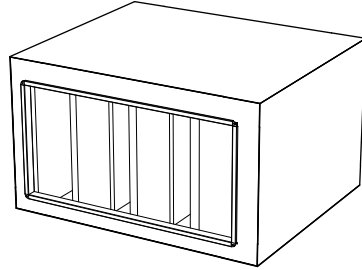

Sound attenuator (code EMT-02)

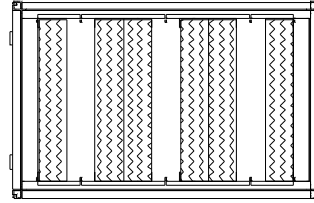

Sound attenuator (code MIE-KL)

The function of the sound attenuator is to reduce the sound level in the system.

Inspection

	<p>DANGER! Risk of serious personal injury and/or damage to air handling unit. Read and understand the entire chapter "1.5 General safety messages" before working on, servicing, or inspecting the air handling unit.</p>
--	---

Check that the baffle elements are intact and have clean surfaces. Take action if necessary.

Cleaning

	<p>DANGER! Risk of serious personal injury and/or damage to air handling unit. Read and understand the entire chapter "1.5 General safety messages" before working on, servicing, or inspecting the air handling unit.</p>
---	---

Vacuum and/or wipe all surfaces with a damp cloth. If more intense cleaning is needed, do so with rotating nylon brushes.

6.15 Filter bypass (code ENFT-10)

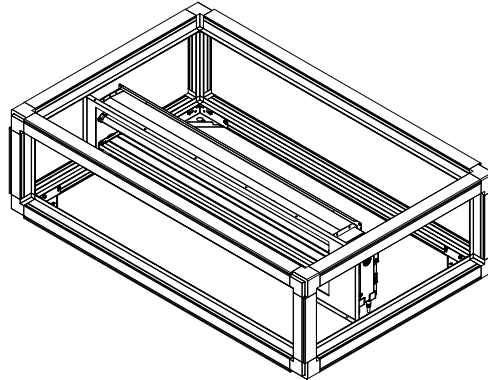

The purpose of the filter bypass is to reroute the air flow in the event of a fire. Faulty function gives rise to disturbances that may result in serious problems.

Inspection



DANGER!
 Risk of serious personal injury and/or damage to air handling unit.
 Read and understand the entire chapter "1.5 General safety messages" before working on, servicing, or inspecting the air handling unit.

1. Check the function of the damper actuator.
2. Check that damper tightens when closed. If they are not sealed, adjust the damper actuator to make the damper tight.
3. Check the sealing strips.
4. If the damper is not working, check that there are no screws penetrating the drive mechanism/damper blades to interfere with damper function.

Cleaning



DANGER!
 Risk of serious personal injury and/or damage to air handling unit.
 Read and understand the entire chapter "1.5 General safety messages" before working on, servicing, or inspecting the air handling unit.

Vacuum and/or wipe all surfaces with a damp cloth. If more intense cleaning is needed, do so with rotating nylon brushes.



Air handling with focus on LCC

You are welcome to contact us

Switchboard:	+46 470 – 75 88 00	
Control system support:	+46 470 – 75 89 00	styr@ivprodukt.se
Service:	+46 470 – 75 89 99	service@ivprodukt.se
Spare parts:	+46 470 – 75 86 00	reservdelar@ivprodukt.se
Visit our website:		www.ivprodukt.com
Documentation for your unit:		docs.ivprodukt.com
Technical documentation:		du@ivprodukt.se