

Installation of 3-phase transformers

Noratel standardmodels - vector group / wiring diagram / marking of terminals

Wiring diagram 1

- Article no. 3-040-xxxxxx
- 3x230/400 Volt

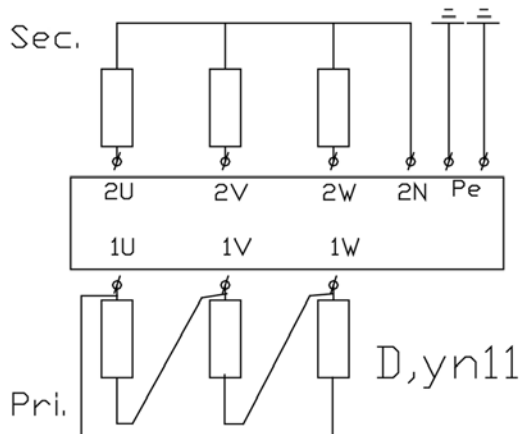

Wiring diagram 2

- Article no. 3-010-xxxxxx
- 3x400/230 Volt

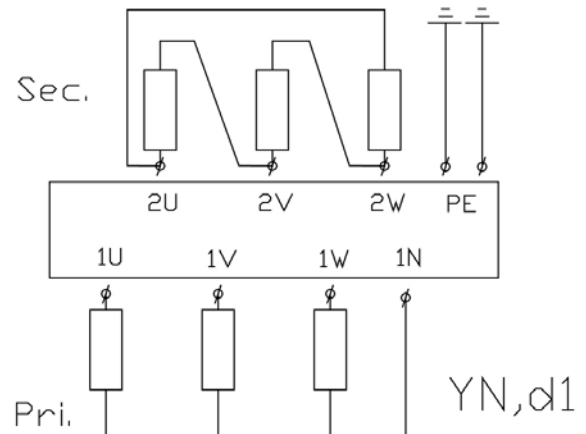

- If the 3x400 Volt secondary voltage is suppose to feed a TN-S network the Neutral conductor (N) must be connected to ground - from this point should then be continued separated as Protective Earth (PE) and Neutral (N) conductor to consuming device

- In the case of 3x400 Volt primary voltage (supply voltage), do not connect the Neutral (N) conductor



In the case of a TN-S network based on a standard European 400 Volt, - where 3x400 Volt is primary voltage (supply voltage) on the transformer, the Neutral (N) conductor is NOT to be connected.

The reason is for this is, if there is a unbalanced load on the secondary side there is a risk of high currents in the Neutral (N) conductor and in some cases primary cables have burned due to improper installation.

- **Note!**

Accompanying COPAL bimetal sheet (63 kVA->) shall be used when connecting cables with copper lugs.

Noratel 3-phase standardmodels - terminals / fuses / losses

Noratel Art. no.	Power kVA	Voltage Pri. / Sec. V	Terminal Type	Torque		Wir. diagram no.	Recommended primary fuse		No-load loss W	Full load loss W
				CU-kabel NM	Alu. kabel NM		230 V	400 V		
3-040-600900	0,63	3x230/400	TRKSD 4 OG	*	*	I	4A		23	65
		alt. 3x400/230	TRKSD 4 OG	*	*	I		4A	23	65
3-040-601100	1,25	3x230/400	WKN 4/U	0,5 - 0,7	0,7	I	6A		36	94
		alt. 3x400/230	WKN 4/U	0,5 - 0,7	0,7	I		6A	36	94
3-040-601400	2,5	3x230/400	WKN 4/U	0,5 - 0,7	0,7	I	10A		56	126
		alt. 3x400/230	WKN 4/U	0,5 - 0,7	0,7	I		10A	56	126
3-040-601700	4	3x230/400	WKN 10/U	2,0 - 2,5	2,5	I	16A		90	258
		alt. 3x400/230	WKN 10/U	2,0 - 2,5	2,5	I		16A	90	258
3-040-602150	6,3	3x230/400	WKN 10/U	2,0 - 2,5	2,5	I	20A		128	374
3-010-505740	6,3	3x400/230	WKN 10/U	2,0 - 2,5	2,5	2		13A	128	374
3-040-602306	10	3x230/400	UT 16 GY	2,0 - 2,5	2,5	I	32A		168	462
3-010-505752	10	3x400/230	UT 16 GY	2,0 - 2,5	2,5	2		20A	168	462
3-040-602400	12,5	3x230/400	WKN 16/U	2,0 - 2,5	2,5	I	32A		247	673
3-040-602500	16	3x230/400	WKN 35/U	3,0 - 4,0	4,0	I	50A		270	655
3-010-505760	16	3x400/230	WKN 35/U	3,0 - 4,0	4,0	2		25A	270	655
3-040-602600	20	3x230/400	WKN 35/U	3,0 - 4,0	4,0	I	63A		280	652
3-010-505765	20	3x400/230	WKN 35/U	3,0 - 4,0	4,0	2		40A	280	652
3-040-603100	25	3x230/400	WKN 35/U	3,0 - 4,0	4,0	I	80A		387	883
3-010-505770	25	3x400/230	WKN 35/U	3,0 - 4,0	4,0	2		40A	387	883
3-040-603200	30	3x230/400	WKN 35/U	3,0 - 4,0	4,0	I	80A		494	966
3-010-505780	30	3x400/230	WKN 35/U	3,0 - 4,0	4,0	2		50A	494	966
3-040-700410	40	3x230/400	UKH 70	6,0 - 10,0	10,0	I	125A		132	1200
		alt. 3x400/230	UKH 70	6,0 - 10,0	10,0	I		80A		
3-040-700510	50	3x230/400	UKH 70	8,0 - 10,0	10,0	I	150A		172	1250
		alt. 3x400/230	UKH 70	8,0 - 10,0	10,0	I		100A		
8-040-800630	63	3x230/400	Alu-bar 30x10	*	*	I	200A		191	1430
		alt. 3x400/230	Alu-bar 30x10	*	*	I		125A		
3-040-700810	80	3x230/400	Alu-bar 30x10	*	*	I	250A		232	1600
		alt. 3x400/230	Alu-bar 30x10	*	*	I		160A		
8-040-801000	100	3x230/400	Alu-bar 30x10	*	*	I	315A		258	2200
		alt. 3x400/230	Alu-bar 30x10	*	*	I		160A		
8-040-801250	125	3x230/400	Alu-bar 30x10	*	*	I	355A		356	2780
		alt. 3x400/230	Alu-bar 30x10	*	*	I		250A		
8-040-801600	160	3x230/400	Alu-bar 40x10	*	*	I	500A		378	3300
		alt. 3x400/230	Alu-bar 40x10	*	*	I		315A		
8-040-802000	200	3x230/400	Alu-bar 40x10	*	*	I	630A		470	3910
		alt. 3x400/230	Alu-bar 40x10	*	*	I		400A		
3-040-702510	250	3x230/400	Alu-bar 60x10	*	*	I	800A		640	4100
		alt. 3x400/230	Alu-bar 60x10	*	*	I		500A		

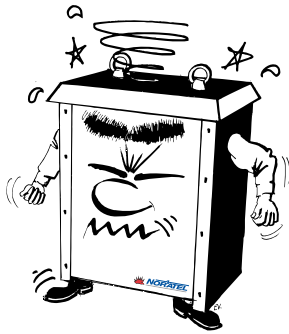

Transportation & handling

- Any transformer with unprotected windings are exposed to impact and touch. Direct blow to the windings and accessories may cause insulation failure or short circuit
- Use the eye lugs or pallet and a fork lift
Transformer weight specified on the label
- Keep the plastic packaging on for as long as possible even when installing

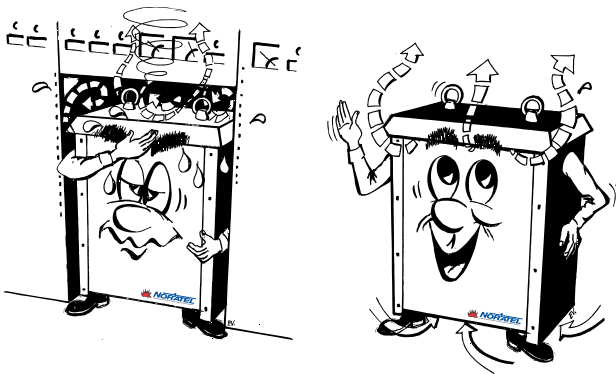

Placement / connection

- If terminal blocks are mounted on the transformer these are approved for connecting both copper and aluminum cables
- Remember that an IP23 transformer is designed for free air flow from around all sides, from bottom to top
- When adding / connecting cables please pay attention to airflow and heat
- Fresh air from below the transformer - Warm air out on the top!

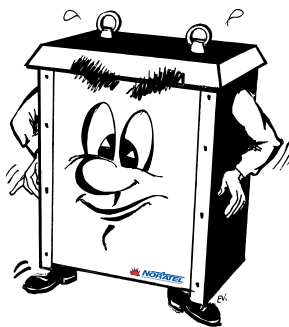

Fuses / Protection

- Recommended primary fuse is specified in the table.
- Primary fuse is must be of **slow blow** type
- The transformer must be protected against overload and short circuit in the installation - maximum current is indicated on the nameplate

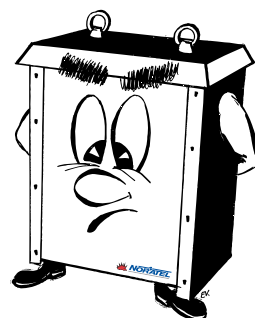

Storage

- Transformers should be stored dry in the temperature range 0-40°C, maximum relative humidity 80%
- Do not store anything heavy on the transformer
- Keep the plastic packaging on the storage



Operation / Maintenance

- Keep the transformer free of rain and similar conditions



- Do not use welding equipment, grinders or similar equipment close to the transformers unless they are surrounded completely with protective wrapping



- Do not sit or walk on the capsule



- Do not cover the transformer
- Do not store any heavy equipment on top of the transformer

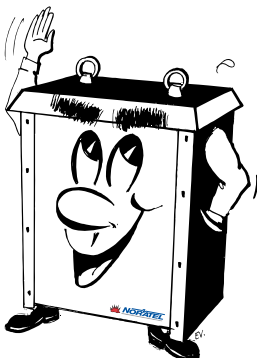

Good luck!