

# A-SENSE AND UG3-A-SENSE

Carbon dioxide and temperature sensor. Duct or room installation.



## TECHNICAL DATA

<b>Power supply:</b>	24 V AC/DC±20%, 50-60 Hz half-wave-rectified input)
<b>Current drain:</b>	< 3 W (120 mA) average
<b>Linear outputs:</b>	OUT1 and OUT2, 0/2-10V DC, max 2 mA or 0/4-20 mA, Rload < 500 Ohm. Outputs are configured with jumpers for voltage/current and 0-100% / 20-100%
<b>Relay output (optional):</b>	OUT3: NO. Contactless relay, min. load 1 mA/5 V, max. load 0.5 A/125V AC or 1A/24V DC
<b>Operating temperature:</b>	0 to + 50°C
<b>Storage temperature:</b>	-20 to + 70°C
<b>Operating humidity:</b>	0 to 95% RH (non-condensing)
<b>Start time:</b>	≤ 1 min. (@ full spec ≤ 15 minutes)
<b>Sensor life expectancy:</b>	> 15 years
<b>Measurement principle:</b>	Non-dispersive infrared (NDIR) with automatic baseline correction (ABC)
<b>Gas collection:</b>	Diffusion
<b>Response time (T1/e):</b>	2 min. diffusion time
<b>Accuracy:</b>	Normally ±1% of measuring range ±5% of measured value
<b>Annual zero point drift:</b>	< ±0.3% of measuring range
<b>Temperature measurement principle:</b>	Thermistor
<b>Measuring range:</b>	-20 to +60°C
<b>Accuracy temperature:</b>	Normally ± 1°C*
<b>PC progr. software:</b>	UIP4
<b>Dimensions (HxWxD):</b>	Wall installation 120x82x30 mm Duct installation 180x150x154 mm
<b>Protection:</b>	Wall installation IP20 Duct installation IP54
<b>Air sampling tube:</b>	Aluminium, weight 400g.

## FEATURES

- Infrared technology (NDIR)
- Auto self-diagnostics
- Normally maintenance-free
- Network communication via RS485 as an option
- Modbus as an option

## FUNCTION

A-SENSE is a microprocessor-based temperature and carbon dioxide transmitter for installation in the climate zone. A-SENSE senses the surrounding air, converts the result into analog and digital signals, and sends them on to higher-level systems. A-SENSE is available with or without display and relay, and for room or duct installation. Auto-calibration (ABC-function) is the key to maintenance-free operation. The precondition for this is a normal indoor environment, or applications in which there is some type of ventilation (at least a few times a week.)

## GENERAL INFORMATION

A-SENSE is designed to control ventilation by transmitting the measured carbon dioxide content and temperature to the system DUC (dataundercentral = data subcentre). According to the BBR 94 rules of The National Swedish Board of Housing, Building and Planning, the flow of outside air where people spend time more than occasionally, should amount to at least 7 litres per second per person. Assuming that the individuals in the room are adults doing sedentary work and that the outdoor concentration is 350 ppm, this flow corresponds to a carbon dioxide content of about 1040 ppm. According to The National Board of Health and Welfare (Socialstyrelsen) (SOSFS 1989:51) and The National Board of Occupational Safety and Health (Arbetskyddsstyrelsen) (AFS 1993: 5) the carbon dioxide content can therefore be used as an indicator that the air flow, and therefore the air quality, is satisfactory. A carbon dioxide content below 1000 ppm should therefore be aimed at, according to both those official bodies.

## MAINTENANCE

A-SENSE is normally maintenance-free if the auto-calibration function (ABC) is activated.

## WIRING DIAGRAM

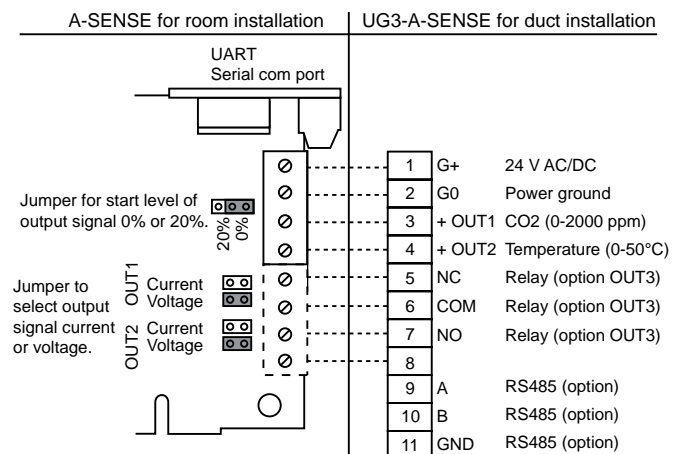

\* In the duct mounted version (UG3-A-SENSE), the temperature accuracy is dependent of the ambient temperature by the UG3-A-SENSE. In case of big temperature difference inside and outside the duct, the accuracy can be more than ±1°C. Note that the temperature measurement function requires air flow in the duct.

# A-SENSE AND UG3A-SENSE

Carbon dioxide and temperature sensor. Duct or room installation.



## INSTALLATION

Wall mounted version: Mounting place; avoid exposure of direct sunlight, air draught from ventilation, doors or windows. When mounted over a conduit box or conduits, these must be made tight in order to avoid air draught that could affect the sensors function and accuracy.

Duct mounted version: The venturi pipe is made of aluminium and can easily be shortened to suit the diameter of the duct. Hole diameter is 38 mm. For insulated and/or circular ducts use a special mounting bracket and a gasket. The hole diameter is then 51 mm.

The length of the venturi pipe shall be chosen based upon how wide the ventilation duct is. The venturi pipes are available in 3 lengths; 0,6, 1,5 and 2,8 m. When the ventilation duct is wider than 0,6 m (dia), the venturi pipe should penetrate the **whole** duct. Please see below sketch.

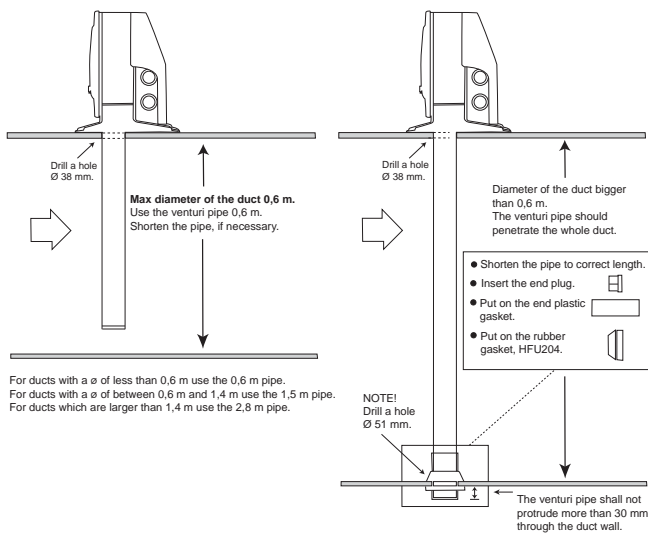

For more information please see the installation instruction enclosed with the product.

## ORDERING EXAMPLE

Item code	Designation
A-SENSE	Wall mounting without display
A-SENSE-D	Wall mounting with display
A-SENSE-MB	Wall mounting Modbus, without display
UG3-A-SENSE	Duct sensor without display, incl. VR-0.6M
UG3-A-SENSE-D	Duct sensor with display, incl. VR-0.6M
UG3-A-SENSE-MB	Duct sensor Modbus, without display, incl. VR-0.6M

For A-SENSE with relay output, IP54 industrial enclosure, Modbus or RS485, please contact our sales department.

## ACCESSORIES

Item code	Designation
USB CABLE	Programming cable
2001M	Zero-calibration bag
VR-0.6M	Venturi pipe 0.6 meter for UG-3
VR-1.5M	Venturi pipe 1.5 meter for UG-3
VR-2.8M	Venturi pipe 2.8 meter for UG-3
UG-MB	Mounting bracket for UG-3/4

## STANDARD CONFIGURATION OF OUTPUTS

Terminal	Standard configuration	Standard-configuration
OUT 1	0-10 V DC	0-2000 ppm CO <sub>2</sub>
OUT 2	0-10 V DC	0-50°C
OUT 3 option relay	Closed Opened	>1000 ppm CO <sub>2</sub> <900 ppm CO <sub>2</sub>

## DIMENSIONS (mm)

