

UG-3-A40 UNIGUARD SUPERFLOW STAND-ALONE-UNIT 24V

Optical smoke detector with service alarm for duct installation.



TECHNICAL DATA

Voltage Supply: 24V AC/DC $\pm 10\%$
Detector type: Optical UG-3-A40
Max. power consumption: 165 mA
Operating temperature: -10°C to $+55^{\circ}\text{C}$
Maximum humidity: 99% rH
Duct air velocity range: Approx. 0,2 to 20 m/s

Approvals

Detector head: EN-54-7
Relay output: Potential free
Smoke alarm relays: Two changing contacts 250V, 5A
Service alarm: One breaking contact 250V, 5A
LED on smoke detector: Green - service alarm
Red - smoke alarm
LED on PCB: Green - normal operation
Yellow - service alarm
Red - smoke alarm

Adaptor housing: ABS
Protection: IP54
Air sampling tube: Aluminium.

Standard length 0,6 m. Hole diameter 38 mm.

The length of the venturi pipe shall be chosen based upon how wide the ventilation duct is. The venturi pipes are available in 3 lengths; 0,6, 1,5 and 2,8 m. When the ventilation duct is wider than 0,6 m (dia), the venturi pipe should penetrate the **whole** duct. Please see below sketch.

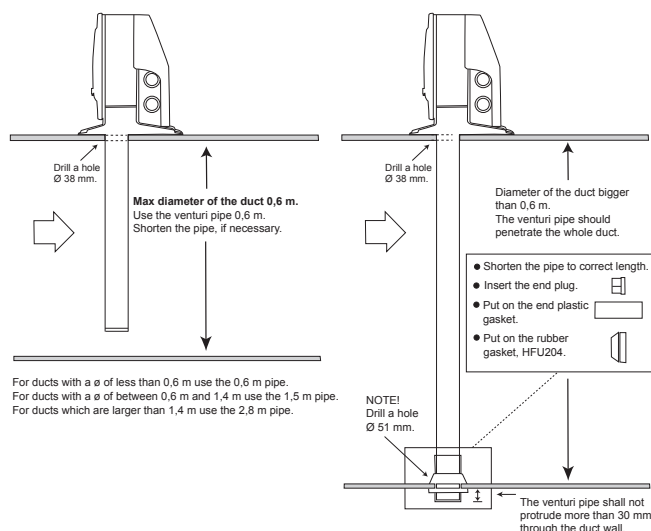

CHARACTERISTICS

- Patented venturi pipe and duct housing
- One-pipe air sampling system Uniguard Superflow
- New cross-section (shape) of the venturi pipe gives an optimum of venturi effect
- Service alarm
- Test hole on cover
- Simple installation
- Sensitive flow indicator
- Simple service and maintenance
- Installer-friendly connection of cables
- Foolproof installation of venturi pipe

FUNCTION

Uniguard has been developed to detect smoke in ventilation ducts and combines a smoke detector and an adaptor system where both tube and housing are specially designed for optimum airflow through the smoke detector.

There is a built-in **alarm relay** to control fire-safety dampers, to stop ventilation fans, or to activate acoustic and optical alarms etc.

There is a built-in **service alarm** relay to let you know when maintenance is needed, before a false alarm occurs.

The detector contains an intelligent controlling circuit. This circuit is adjusting the sensitivity to give an optimal function during the whole life time of the detector. When the controlling circuit can no longer compensate for contamination, a service alarm is indicated.

Uniguard Superflow has 4 premounted IP67 approved cable entries with built-in cable anchorage for diameter 4-11 mm, type Klikseal.

The detector has a bayonet fitting to simplify mounting and removal.

ORDER EXAMPLE

| Item code | Designation |
|-----------|---|
| UG-3-A40 | Uniguard Superflow stand-alone-unit 24V |

ACCESSORIES

| Item code | Designation |
|-----------|---|
| UG-MB | Mounting bracket (for insulated/circular ducts) |
| UG-COVER | Waterproof housing (for mounting outdoors, in cold attics etc.) |
| VR-0.6M* | Venturi tube (length 0,6 m) |
| VR-1.5M* | Venturi tube (length 1,5 m) |
| VR-2.8M* | Venturi tube (length 2,8 m) |
| ST-EXTEND | Extension of venturi tube VR & ST, 1.06M |

* The venturi tubes are sold separately.

UG-3-A40 UNIGUARD SUPERFLOW STAND-ALONE-UNIT 24V

Optical smoke detector with service alarm for duct installation.



BASIC PRINCIPLES FOR POSITIONING

For the airflow through the adaptor to be representative of the airflow in the ventilation duct, install the detector at a place where flow meters etc. normally are mounted, please see our installation instructions.

You can also use your national or local rules for moutage according to "Methods for measuring airflow in ventilation systems".

INSTALLATION

The venturi pipe is made of aluminium and can easily be shortened to suit the diameter of the duct. Hole diameter is 38 mm. For insulated or circular ducts - use the mounting bracket, hole diameter is then 51 mm.

MAINTAINANCE

When the detector becomes contaminated, sensitivity is increased, triggering the service alarm. This can be avoided for a considerable time by cleaning the detector once a year with a vacuum cleaner.

AIR FLOW MONITORING

The detector is fitted with a red plastic switch tongue. When the detector is correctly installed, the tongue is bent outwards by the air flow. The switch tongue provides a simple confirmation that there is no leakage and that the air flow from the duct is in fact flowing through the housing.

FUNCTION TEST

When installation is complete, the detector should be tested. This can be carried out with smoke or suitable aerosol testspray.

NB: When installing outdoors or in cold attics etc., where there is a risk for condensation, the detector should be insulated from the surrounding air with e.g. our weatherproof housing UG-COVER. In such cases it should be marked with a sign "Hidden Detector".

FUNCTION

- Normal operation:** In normal operation the alarm relay is energized, and the relay contacts are closed between C and NC.
- Smoke alarm:** The LED of the detector is showing red light and the relay contacts are changing to C and NO.
- Reset:** Press the reset button to reset the detector into normal operation.
- Service alarm:** When the detector is sensing smoke or is dirty the LED of the detector will first show green colour before going into alarm with red light. If the detector is dirty, it will show green light. This is an optical indication (a pre-alarm or service-alarm) which means that the detector is contaminated and if it is not cleaned, it will give a false alarm later on.

Failure:

If there is something wrong with the detector, the alarm relay will change contacts:

- When the detector module is removed
- When the supply voltage is interrupted

DIMENSIONS (mm)

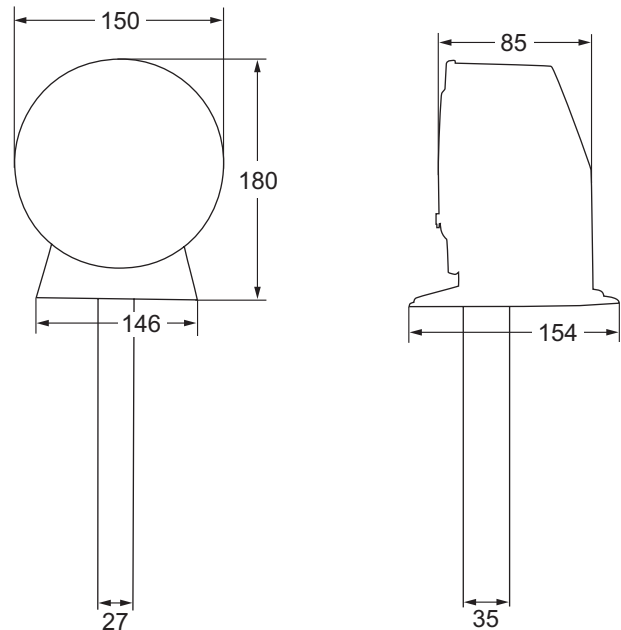

WIRING DIAGRAM

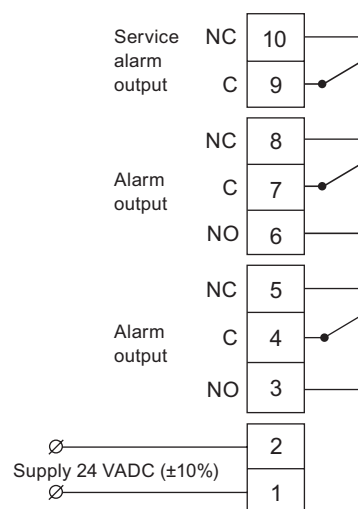

Alarm relay:
TWO changing contacts, max 250V, 5A, each.

The relay outputs are shown in normal operation/power on condition.