Operation and Maintenance

Envistar Compact



Order number:

Project:



Unit specifications

Unit type

ACER

ACEC Output var 1 2 3

Home Concept model

Control equipment

MX

UC

MK

US

Unit parts and accessories

Recovery rotor ACRR

Air heater water ECET-VV

ThermoGuard ECET TV

Air heater electric ECET-EV

Output var 1 2 3

Air cooler water

ETKB-VK ECET-DX

Damper ECET-UM, ECET-TR

Sound attenuator ECET-LD

Size

04

06

10

16

Filter supply air

ePM10-60% / M5

ePM1-50% / F7

ePM1-60% / F7

Excl. filter

Set of filters Black Ridge BR

Filter extract air

ePM10-60% / M5

ePM1-50% / F7

ePM1-60% / F7

Excl. filter

Set of filters Aluminium filter AL



Table of Contents

1	Safety precautions	1
1.1	Personal protective equipment	1
1.2	Prevent injury to personal and damage to air handling units	1
1.3	Product signs, information and warning stickers	2
1.4	Safety message	2
1.5	General safety messages	3
2	General	6
2.1	Intended use	6
2.2	Manufacturer	6
2.3	Designations	6
2.4	CE marking and EU Declaration of Conformity	7
2.5	Maintenance	8
2.6	Handling of refrigerant	8
2.7	Extended warranty	9
2.8	Spare parts	9
2.9	Dismantling and decommissioning	9
3	Technical description	10
3.1	Envistar Compact air handling unit	10
3.2	Home Concept	10
3.3	StarCooler cooling unit (code ACEC)	11
4	Wiring instructions and fuse protection	13
4.1	MX – Complete control equipment	
	UC – Complete electrical connection to terminal without controller unit	13
4.2	MK – Fans and heat exchangers electrically connected to terminal	13
4.3	US, HS - Without control and without electrical connection	14



Table of Contents, Cnt'd

5	Operation	16
5.1	Hygiene inspection	16
5.2	Actions in case of standstill	16
5.3	Commissioning	17
6	Maintenance instructions	18
6.1	Service schedule	18
6.2	Filter (code ACEF)	20
6.3	Rotary heat exchanger (code ACRR)	24
6.4	Air heater water (ECET-VV) and Thermoguard (ECET-TV)	28
6.5	Air heater electric (code ECET-EV)	30
6.6	Air cooler water (code ECET-VK) and Air cooler for direct expansion (code ECET-DX)	32
6.7	Fan unit	34
6.8	Damper (code ECET-UM, ECET-TR)	38
6.9	Sound attenuator (code ECET-LD)	39
6.10	StarCooler cooling unit (code ACEC)	40
7	Troubleshooting	41
7.1	StarCooler cooling unit (code ACEC)	41



1 Safety precautions

Follow all safety precautions in this document and pay attention to all warning signs on the air handling unit.

Failure to comply with the safety precautions may result in injury to persons or damage to air handling units.

1.1 Personal protective equipment

Personal protective equipment must always be used based on the risks present at the workplace. Comply with national and local laws and regulations.

The following personal protective equipment is recommended where the work requires:

- Protective shoes with steel cap
- Hearing protectors
- Safety helmet
- Gloves
- Goggles
- Covering clothing
- Protective overalls
- Mouthguard/protective mask
- Fall protection

1.2 Prevent injury to personal and damage to air handling units

To avoid injury to persons or damage to air handling units, pay attention to the following:





- Read the entire document before working on the unit.
- Comply with national and local laws and regulations for work safety.
- Do not wear loose clothing or jewellery that may get fasten.
- Do not step or climb on the heater.
- Use recommended tools and equipment intended for the job.
- Use recommended personal protective equipment when the work requires it.
- Observe the unit's product signs, information and warning stickers.
- Keep the unit clean and follow operating and care instructions.
- Make sure that all hatches are in place, that inspection hatches are closed and that lockable inspection hatches are locked before starting the unit and after repairs/service.
- Use appropriate fall protection when working at heights - normally over 2 meters. Even work at lower heights may require protective measures.

1.3 Product signs, information and warning stickers

Keep signs and stickers free from soiling and replace them if they are lost, damaged or illegible. Contact IV Produkt for replacement stickers; specify the item number.

1.4 Safety message

The following warning symbols and signal words are used in this document to inform of risks.

 DANGER!	Danger - indicates an imminent dangerous situation which, if not avoided, can result in death or serious injury.
 WARNING!	Warning - indicates a potentially dangerous situation which, if not avoided, can lead to serious injury.
 CAUTION!	Caution - indicates a less potentially dangerous situation which, if not avoided, can lead to less serious or minor injuries.
 NB!	NB! – indicates a potentially hazardous situation which, if not avoided, may result in damage or impaired operation of the air handling unit.

1.5 General safety messages

Comply with the following general safety messages.

Lockable safety switch

	<p>DANGER! Risk of serious injury. Electrical power can cause electric shock, burns and death.</p> <p>Working on/servicing the unit – Shut down the unit via the service switch in the control equipment, then turn the safety switch to the 0 position and lock it.</p> <p>There may be several safety switches serving the different parts of the unit. All safety switches must be switched off before repairs/service.</p>
---	---

	<p>NB! The safety switch is not designed for starting/stopping the unit. Always use the service switch in the control equipment to start and shut down the unit.</p>
---	--

Electrical connection

	<p>DANGER! Risk of serious injury. Electrical power can cause electric shock, burns and death.</p> <p>Working on/servicing the unit – Shut down the unit via the service switch in the control equipment, then turn the safety switch to the 0 position and lock it.</p> <p>There may be several safety switches serving the different parts of the unit. All safety switches must be switched off before repairs/service.</p>
---	---

	<p>WARNING! Risk of personal injury. Rotating fan impellers can cause crushing injuries or lacerations. The unit must not be energised until all ducts have been connected.</p>
---	---

	<p>NB: Wiring of connections and other electrical work may only be carried out by a qualified electrician or by service personnel recommended by IV Produkt.</p>
---	--

Inspection hatches

**WARNING!**

Risk of personal injury.
Overpressure in unit.

Allow the pressure to drop before you open the inspection doors.

**WARNING!**

Risk of personal injury.

The doors in front of moving parts shall normally be locked; there are no safety guards.

During repairs/service, the inspection doors are locked with the supplied keys.

Make sure that all hatches are closed and that lockable inspection hatches are secured before starting the unit and after repairs/service.

Cooling unit

**WARNING!**

Risk of personal injury.

Hot surfaces can cause burns.

Working on/servicing the unit – Shut down the unit via the service switch in the control equipment, then turn the safety switch to the 0 position and lock it.

There may be several safety switches serving the different parts of the unit. All safety switches must be switched off before repairs/service.

Wait at least 30 minutes before opening the compressor inspection doors.

Heating coil

**WARNING!**

Risk of personal injury.

Hot surfaces can cause burns.

Working on/servicing the unit – Shut down the unit via the service switch in the control equipment, then turn the safety switch to the 0 position and lock it.

There may be several safety switches serving the different parts of the unit. All safety switches must be switched off before repairs/service.

Wait at least 5 minutes before opening the battery inspection doors.

Fan



WARNING!

Risk of personal injury.

Rotating fan impellers can cause crushing injuries or lacerations.

Working on/servicing the unit – Shut down the unit via the service switch in the control equipment, then turn the safety switch to the 0 position and lock it.

There may be several safety switches serving the different parts of the unit. All safety switches must be switched off before repairs/service.

Wait at least 3 minutes before opening inspection hatches.

Rotary heat exchanger



WARNING!

Risk of personal injury.

Rotating thermal wheels can cause crushing injuries or lacerations.

Working on/servicing the unit – Shut down the unit via the service switch in the control equipment, then turn the safety switch to the 0 position and lock it.

There may be several safety switches serving the different parts of the unit. All safety switches must be switched off before repairs/service.

Wait at least 3 minutes before opening inspection hatches.

Damper



WARNING!

Risk of personal injury.

Moving parts can cause crushing injuries. Never place your hands inside the damper when it closes.

Working on/servicing the unit – Shut down the unit via the service switch in the control equipment, then turn the safety switch to the 0 position and lock it.

There may be several safety switches serving the different parts of the unit. All safety switches must be switched off before repairs/service.

Some dampers are closed via spring return in a de-energized state.

Wait at least 3 minutes for the damper to close.

Filter



WARNING!

Risk of personal injury – harmful dust.

Use a face mask/respiratory protection to avoid inhaling dust.

2 General

2.1 Intended use

The air handling units in the Envistar Compact series are intended for comfort ventilation in buildings.

When installed indoors, the unit must be installed in an area that maintains a temperature between +7 and +30°C, and with a moisture content of <3.5 g/kg in dry air in the winter. The unit can also be equipped for outdoor installation.

Any other use and installation in other environments are prohibited unless specifically permitted by IV Produkt AB.

It is not permitted to use the unit in potentially explosive environments, Eex.

2.2 Manufacturer

The Envistar air handling units (AHUs) are manufactured by:

IV Produkt AB
 Sjöuddevägen 7
 S-350 43 VÄXJÖ

2.3 Designations

The Envistar Compact is manufactured as a compact unit, and the StarCooler cooling unit can be integrated as an optional extra.

The compact unit and cooling unit (if selected) have a model type plate affixed to the front.

The model type plate shows the series number and the requisite designations to identify the unit.



Typical model identification label

2.4 CE marking and EU Declaration of Conformity

The air handling units and any cooling unit (if selected) are CE marked, which means that upon delivery they conform to applicable provisions in EU Machinery Directive 2006/42/EC as well as to other EU Directives applicable to the types of air handling units, e.g. Pressure Equipment Directive PED 2014/68/EU.

As certification confirming that the requirements have been met, we provide an EU Declaration of Conformity, which is available under Documentation at ivprodukt.docfactory.com, or under Order Unique Documentation at docs.ivprodukt.com.

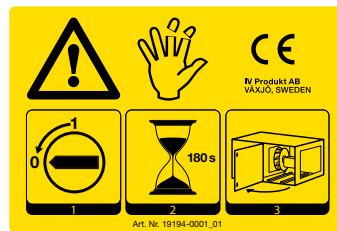

Typical CE label for air handling units

Cooling unit	
Order number	<input type="text"/>
Code Key	<input type="text"/>
Model	<input type="text"/>
Name of project	<input type="text"/>
Date of manufacture	<input type="text"/>
PS Max allowable pressure	<input type="text"/>
PT Test pressure	<input type="text"/>
TS Temperature range	<input type="text"/>
Protection level - low	<input type="text"/>
Protection level - high	<input type="text"/>
Refrigerant / Fluid group	<input type="text"/>
GWP	<input type="text"/>
Refrigerant charge Circuit 1	<input type="text"/>
Refrigerant charge Circuit 2	<input type="text"/>
Refrigerant charge Circuit 3	<input type="text"/>
<small>Contains fluorinated greenhouse gases covered by the Kyoto protocol.</small>	
 0409 IV Produkt AB VÄXJÖ, SWEDEN	

Typical CE label for cooling units

For units without integrated control equipment

The EC declaration applies only to units in the condition in which they have been delivered and installed at the facility in accordance with the enclosed installation instructions. The declaration does not include components that were subsequently added or measures subsequently taken on the unit.

2.5 Maintenance

The ongoing maintenance of this unit can be carried out either by the person normally in charge of maintaining the building or through a contract with a well-reputed service company.

2.6 Handling of refrigerant

The following information summarises the requirements and guidelines for handling the refrigerant used in cooling units. For further information, see the F-gas Regulation (EU/517/2014 on fluorinated greenhouse gases) and the Swedish Refrigerant Regulation (SFS 2016:1128). The purpose of the regulations is to contribute to achieving EU goals for reduced climate impact in accordance with the Kyoto Protocol.

Operator responsibilities

Generally speaking, the unit operator must:

- Minimise and prevent leakage
- Take corrective action to remedy any leakage that arises
- Ensure that the service and repair of the refrigerant circuit is carried out by a certified refrigeration technician
- Ensure that refrigerant is handled in an environmentally secure manner and in accordance with national regulations.

By operator, we refer to the European Parliament's definition: "...the natural or legal person exercising actual power over the technical functioning of the equipment and systems...".

Leakage inspection and registration

The following applies to one-piece units with 5 CO₂ e(tonnes) refrigerant content or more per circuit – Envistar Compact with StarCooler (code ACEC, size 16):

- **Leakage inspection** must be carried out by a certified refrigeration technician:
 - When installing/commissioning the unit
 - Periodically at least once per 12 months, i.e. no more than 12 months between inspections
 - Within one month after any work is performed (for example sealing a leak, replacing a component).
- The operator must **record** events, such as the volume and type of refrigerant topped up, refrigerant taken into possession, results of inspections and work done, person and company who carried out service and maintenance.

For size 04-10, no periodic leak detection or record keeping is needed, but the requirement for leak inspection during installation does apply.

2.7 Extended warranty

In cases in which the equipment delivered is covered by a 5-year warranty, in accordance with ABM 07 with appendix ABM-V 07 or in accordance with NL 17 with appendix VU20, the IV Produkt Service and Warranty Manual is supplied with the product.

In order to claim an extended warranty, a complete, documented and signed IV Produkt Service and Warranty Manual must be presented.

2.8 Spare parts

Spare parts and accessories for this unit can be ordered from IV Produkt's nearest sales office. When ordering, the order number and designation must be given. These are stated on a model type plate, affixed to each component. There is a separate spare parts list for the unit, refer to Order Unique Documentation at docs.ivprodukt.com.

2.9 Dismantling and decommissioning

When an air handling unit is to be dismantled, separate instructions must be followed, see [Dismantling and decommissioning the AHU](#) under Documentation at ivprodukt.docfactory.com.

3 Technical description

3.1 Envistar Compact air handling unit



Envistar Compact is fabricated as a packaged unit in various sizes and as a right- or left-handed version. All units are equipped with rotary heat exchangers and are available as outdoor models. The units can be connected to ducts at the ends or via two of the connections at the top.

The integrated cooling unit StarCooler (code ACEC) is available as an option.

The units can be supplied with or without integrated control equipment.

Envistar Compact with rotor (code ACER) and Envistar Compact with rotor and cooling unit StarCooler (code ACEC) are factory-assembled compact units that are tested and documented at the factory.

3.2 Home Concept

The Home Concept version of the units have, among other things, specially adapted control equipment and air balancing dampers for the extract air. A filter cabinet for aluminium or carbon filters is available as an optional extra.

Envistar Compact with integrated cooling unit is not available in the Home Concept version.

3.3 StarCooler cooling unit (code ACEC)

The cooling unit is equipped with a reciprocating compressor.

Function

Function COOL

The cooling compressor starts when potential-free contact closes from the control unit.

Interlocking

The compressor is interlocked across the ventilation unit. When the ventilation unit stops, the potential-free connector opens for cooling mode and the compressor stops.

Compressor protection

In the event of excess current, or if the safety circuit alarm trips the motor protection, the compressors stop, the connector for the sum alarm closes and an alarm is sent to the control unit.

In the event of an alarm, correct the fault and reset the protective motor switch.



NB!

The high pressure switch has a manual reset button.

The safety circuit alarm will trip in the event of two different faults.

- High pressure in the system, HP
- Low pressure in the system, LP

If the safety circuit alarm trips repeatedly, an authorised refrigeration service company must be called in.

Electrical connection

The junction box contains the following:

- Motor circuit breaker
- Contactor
- Starting equipment

The junction box is mounted inside the cooling unit and has been internally pre-wired and tested at the factory.

Cooling circuit function

A cooling system has four basic components: evaporator, condenser, expansion valve and compressor.

The compressor carries out the work required to run the cooling process.

The evaporator is located in the supply air for the unit. The heat from the outdoor air is taken up in this coil, thereby cooling the supply air.

The energy supplied to the cooling system from the evaporator and the compressor leaves the unit via the condenser in the extract air.

It is important to ensure that the air volumes are above the specified minimum flow on both the outdoor air and extract air side. The process cannot work if these air volumes are not available.

The energy supplied to the cooling system from the evaporator and the compressor leaves the unit via the condenser in the extract air.

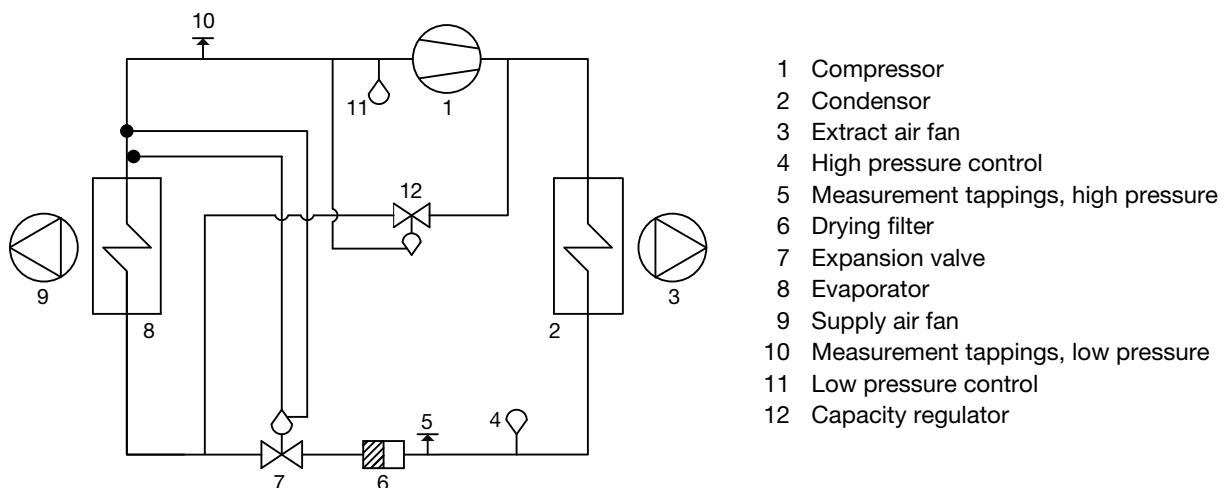

Flow chart for refrigerant system

4 Wiring instructions and fuse protection

4.1 MX – Complete control equipment

UC – Complete electrical connection to terminal without controller unit

Applies to:

- Code MX - units supplied prewired with complete, integrated Siemens Climatix control equipment.
- Code UC - units supplied without controller unit but with sensor and damper actuator connected electrically to the terminal block. Fans and heat exchangers are fused and connected electrically to the terminal. The terminal connections are positioned at a shared place in the unit. For further connection to an external process unit, we recommend using a multi-conductor cable.

Safety switch

A safety switch must be fitted and wired on each power supply.

Wiring diagrams

For wiring diagrams for units with integrated control equipment, refer to the order unique wiring diagram supplied with the unit or docs.ivprodukt.com (Control Diagram).

Unit functions, power supply and fuse protection

For the power supply to the unit functions and recommended external fuse, refer to Order Unique Documentation at docs.ivprodukt.com (Technical Data and Control Diagram), or the product selection program IV Produkt Designer.

4.2 MK – Fans and heat exchangers electrically connected to terminal

Code MK - units supplied without control equipment but with fans and heat exchangers connected electrically to terminals.

Connections to terminal blocks are located on each unit section.

For wiring instructions and recommended fuses, refer to Order Unique Documentation at docs.ivprodukt.com (Terminal Connection and Technical Data).

Safety switch

A safety switch must be fitted and wired on each power supply.

4.3 US, HS - Without control and without electrical connection

- Code US - for units without control equipment and without electrical connection, control diagrams are available for the cooling unit (code ACEC) under order unique documentation at docs.ivprodukt.com, for other connection instructions, see below.
- Code HS - for units without control equipment and without electrical connection with automatic defrosting system, refer to the connection instructions below.

Safety switch

A safety switch must be fitted and wired on each power supply.

Ziehl EC 1x230 V 0,50 / 0.78 kW fan impeller 025 / 028 / 031

Sizes 04, 06 and 10

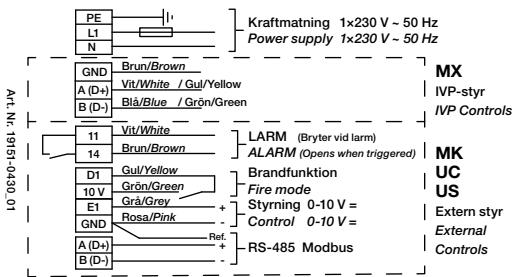

INKOPPLING / WIRING
 Ziehl 1x230 V - BD

Ziehl EC 3x400 V 2.40 / 2.50 kW fan impeller 040

Size 16

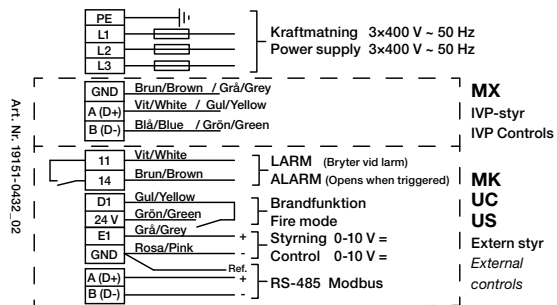

INKOPPLING / WIRING
 Ziehl 3x400 V - DC, DG

Ziehl EC 1x230 V 1.35 kW fan impeller 031

Size 10

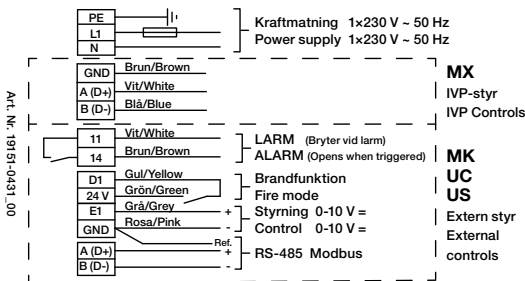

INKOPPLING / WIRING
 Ziehl 1x230 V - DC

Rotary heat exchanger (code ACRR)

OJ Electronics

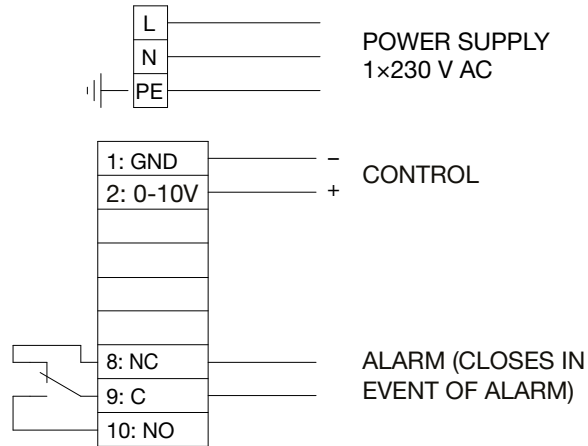

Air heater electric (code ECET-EV)

For power supply, output variant and recommended fuse, refer to Order Unique Documentation at docs.ivprodukt.com (Technical Data).

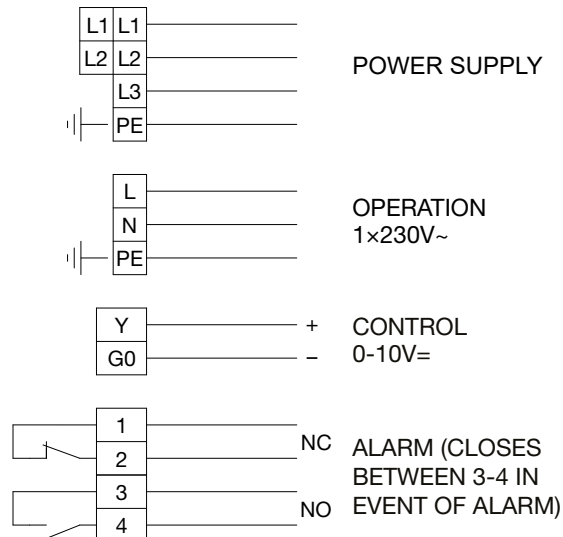

5 Operation

5.1 Hygiene inspection

Envistar Compact conforms to guidelines in VDI 6022 Part 1: Hygiene and Hygiene Inspections of HVAC Systems.

For this to apply, a hygiene inspection of the system must be carried out and the system must be cleaned thoroughly as needed before start-up.

For units (code MK, US,UC):



NB!

Pressure surges on filters and air ducts must be prevented through the design of the duct system and the settings/ configuration of the control system (e.g. gradual start of fans, open damper when the fans are in operation).

5.2 Actions in case of standstill

According to guidelines for hygienic design VDI 6022 Part 1:

In case of prolonged standstill in air treatment systems (more than 48 hours), it should be ensured that no moist areas can be found downstream of the cooling coils or humidifier.

In order to avoid the accumulation of moisture – turn off the cooling coils and humidifier in good time and ventilate the air ducts dry (gradual shut-down). Also, be sure to set up or program the required functions in the building's automation/ control system for automatic dry blowing of air coolers and downstream sections.

5.3 Commissioning

Commissioning of the unit must be carried out by qualified personnel in accordance with the Commissioning Record, which can be downloaded at docs.ivprodukt.com or ivprodukt.docfactory.com.

The commissioning procedure applies to units that are supplied with control equipment (code MX).

The validity of the product warranty is conditional on the system having been commissioned correctly. Working on the unit during the warranty period without the approval of IV Produkt shall render the warranty void.

Installation of cooling units requires leak inspection by a certified cooling technician.

Prior to commissioning, the contractor must:



DANGER!
Risk of serious personal injury and/or damage to air handling unit.
Read and understand the entire chapter "1.5 General safety messages" before working on, servicing, or inspecting the air handling unit.

1. Connect the unit to the power supply via a lockable safety switch.
2. Connect the heating/cooling coil.
3. Connect all ducts.

Follow the troubleshooting instructions in the troubleshooting chart before contacting a service representative for servicing a unit under warranty. This will prevent any unnecessary service calls.







6 Maintenance instructions

6.1 Service schedule

The service schedule comprises actions and service intervals for functional sections that can be part of the air handling unit. For current parts, refer to docs.ivprodukt.com (Technical data).

Make copies of the service schedule for future use before you fill in servicing data for the first time.

For hygiene inspections according to guideline VDI 6022, refer to the separate [VDI 6022 Checklist for Operation and Maintenance, Hygiene checks](https://ivprodukt.docfactory.com) at ivprodukt.docfactory.com.

Service year 20		Order no.		Project				
Comments				Service performed * (date and signature)				
Functional section	Code	Recommended action (insp.)	Page ref.	12 mths	24 mths	36 mths	48 mths	
	Filter supply air, extract air	ACEF	Check pressure drop Change filter if necessary	14	signature	signature	signature	signature
	Rotary heat exchanger	ACRR	Visual inspection Check press. balance Check diff. pressure Control rotor speed Clean if necessary	16	signature	signature	signature	signature
	Air heater water	ECET-VV, ECET-TV	Visual inspection Clean if necessary Check function	19	signature	signature	signature	signature
	Air heater electric	ECET-EV	Visual inspection Clean if necessary Check function	20	signature	signature	signature	signature
	Air cooler water	ECET-VK, ECET-DX	Visual inspection Check drainage Clean if necessary Check function	21	signature	signature	signature	signature
	Fan unit	-	Visual inspection Clean if necessary Check the air flow	22	signature	signature	signature	signature
	Damper	ECET-UM, ECET-TR	Visual inspection Clean if necessary Check tightness	25	signature	signature	signature	signature
	Sound attenuator	ECET-LD	Visual inspection Clean if necessary	26	signature	signature	signature	signature



* In some environments, service may be needed more often. Replace the filter if the pressure drop across the filter exceeds the specified final pressure drop.

Cooling unit

Service year 20								Order no.....		Project			
Comments						Service performed * (date and signature)							
Functional section		Code	Recommended action (insp.)	Page ref.	12 mths	24 mths	36 mths	48 mths					
 Cooling unit		ACEC	Visual inspection Check drainage. Clean if necessary Check function Check for leakage and report if necessary	27	signature	signature	signature	signature					

*More frequent servicing may be required in certain environments.

Home Concept

Service year 20								Order no.....		Project			
Comments						Service performed * (date and signature)							
Functional section		Code	Recommended action (insp.)	Page ref.	12 mths	24 mths	36 mths	48 mths					
 Aluminium filter in filter cabinet		ACET-08F-size-AL	Check pressure drop Clean if necessary	14	signature	signature	signature	signature					
 Carbon filter in filter cabinet		ACET-08F-size-BR	Inspection indication Replace if necessary	14	signature	signature	signature	signature					

* More frequent servicing may be required in certain environments.

6.2 Filter (code ACEF)

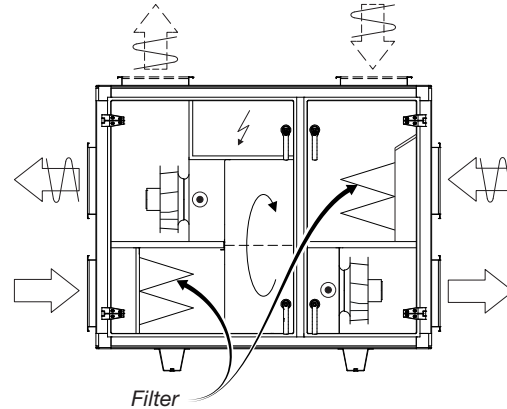

The air filters in an air handling unit are designed to prevent dust and other impurities from entering the building. They should also protect sensitive components inside the unit, e.g. water coils and heat exchangers, from exposure to impurities.

The dust separation efficiency varies considerably between various filter types. The dust collecting efficiency also varies substantially. It is therefore important to use filters of the same quality and capacity when you change them.

According to guidelines for hygienic design VDI 6022 Part 1: The supply air filter must be class ePM1-50% (F7) or have a greater filtration efficiency.

The filters are designed for one-time use. If they become fouled, the unit will lose capacity. The filters should therefore be changed if the pressure drop across them exceeds the specified final pressure drop.

It is important to stop the unit before changing filters to prevent dust from coming loose and being drawn into the unit. The inside surfaces of the filter sections should therefore also be cleaned when the filters are changed.

For the Home Concept version (code ACET-08)

The filter cabinet is an optional extra for the Home Concept version and can be used for

- aluminium filter on the extract air side
- carbon filter on the supply air side

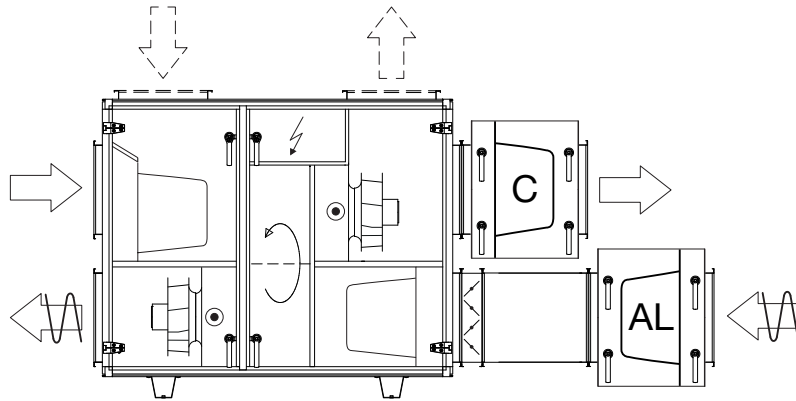

AL - aluminium filter, C - carbon filter, Black Ridge

The aluminium filter is intended for use where the extract air contains grease particles to avoid grease being sucked into the unit. The filter is a knitted flat-type filter. The aluminium filter can be cleaned using hot water and a mild alkaline detergent.

The carbon filter can be used to remove odours in the form of organic and odorous gases/vapours. The carbon filters are fitted to the supply air side. The carbon filters are Black Ridge filters, constructed as compact and highly efficient, molecular filters. The filters are designed for one-time use and the filter is combustible in its entirety.

Lifespan and filter control Carbon filter

The function and lifespan of the carbon filters depends on the volume of air that passes through and on the molecular density of odorous substances. This means that the time intervals for filter replacement can vary from unit to unit depending on operation mode and the volume of odorous substances in the air.

Units delivered with integrated control equipment (code MX) are equipped with the filter control function – FLC (Filter Lifetime Control). FLC indicates when it is time to replace the carbon filter. Indication is through an alarm on the hand-held terminal display.

FLC calculates the volume of air passing through the carbon filters and triggers the alarm for filter replacement when the preset value has been reached. The volume of air passing through is measured in mega cubic metres (Mm³). The function does not take into account the odour content of the air, which means that the indication should be regarded as a recommendation for checking the filter function. If no odours pass through, there is no need to replace the filter.

Preset FLC values, as per the table below, are based on max. air flow over 12 months of full-time operation. If required, the value can be lowered in order to: - change to more frequent filter replacement intervals for max. air flow - retain the filter replacement interval of 12 months for lower air flows. To change the value, see separate Climatix control documentation.

Filter data

For filter data, refer to [Filter Overview](#) under Documentation at ivprodukt.docfactory.com. Actual filters are shown in the unit specification in this document and under Order Unique Documentation at docs.ivprodukt.com (Technical Data and Spare Parts List).

Inspection

	<p>DANGER! Risk of serious personal injury and/or damage to air handling unit. Read and understand the entire chapter "1.5 General safety messages" before working on, servicing, or inspecting the air handling unit.</p>
--	---

Check the pressure drops across the filters (not carbon filter Black Ridge in Home Conceptversion). Pressure drop is measured with a manometer connected to measurement outlets. The measurement outlets are connected to each side of the filter.

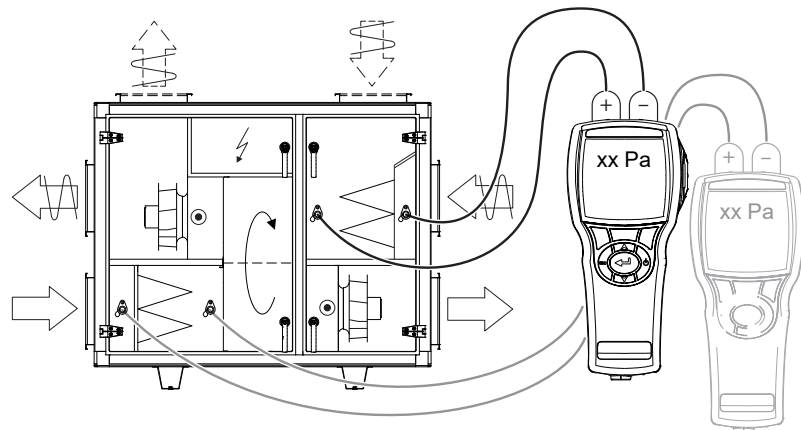

If the filter has reached its specified final pressure drop, it should be changed. The final pressure drop is specified on the filter section decal (filled in when the air handling unit is put into operation).

Also carry out a visual inspection of the filter for damage and deposits.

FILTERDATA

Nominellt luftflöde m³/s
 Nominal air flow..... m³/h

Antal filter Mått
 Number of filters.....Dimensions.....

.....

.....

Filterklass/Filter Class.....

Begynnelsestryckfall
 Initial Pressure Drop.....Pa

Sluttryckfall
 Final Pressure Drop.....Pa

Art. Nr: 19121-1101_02SV

Filter replacement



DANGER!
 Risk of serious personal injury and/or damage to air handling unit.
 Read and understand the entire chapter "1.5 General safety messages" before working on, servicing, or inspecting the air handling unit.

1. Shut down the unit via the service switch in the control equipment, safety switch in the 0 position.
2. Wait until the fans have stopped, then open the inspection door.
3. Release the eccentric rails.
4. Remove the old filter by pulling it towards you.
5. Clean the filter cabinets.
6. Install the new filter, press in the eccentric rails to engage them and close the inspection door.
7. Reset the FLC filter control function via the Climatix display, refer to separate Climatix control documentation. (Only applicable to the Home Concept version of the unit with carbon filter and integrated control equipment (code MX).)
8. Start the unit.

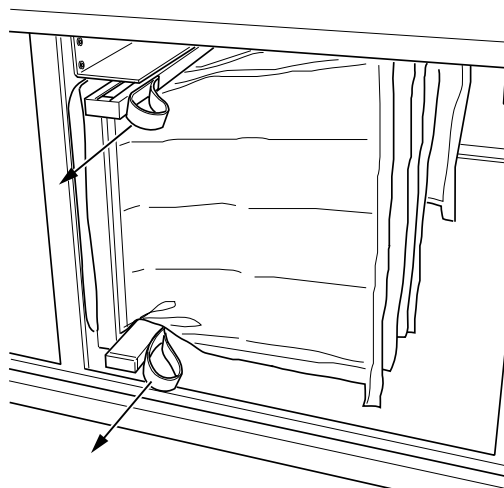

Eccentric rails inside the unit

6.3 Rotary heat exchanger (code ACRR)

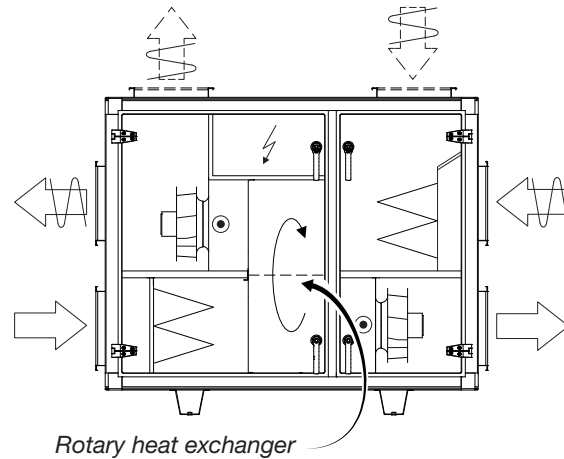

The purpose of the recovery unit is to recover heat from the extract air and transfer this heat to the supply air in order to minimise energy use.

Faults in recovery unit functionality result in reduced heat recovery efficiency and increased energy use and means that the design supply air temperature cannot be obtained when the outdoor temperature is low.

A conceivable reason for reduced recovery efficiency may be that the rotor rotates too slowly because the drive belt is slipping. The rotor speed should not be lower than 8 rpm during full energy recovery.

It is not usual for the rotor passages to become fouled with dust, since the rotor is normally self-cleaning. However, this might occur if the dust is of a sticky nature.

A reduction of the extract air flow, e.g. due to fouling of the extract air filter, entails reduced heat recovery efficiency.

The Home Concept version of the units is equipped with a control function for the pressure balance over the purge sector, which means that the pressure balance does not have to be inspected or adjusted. For units supplied with integrated control equipment, the function is connected and activated at the factory. For units not supplied with control equipment this function has to be connected to the unit.

Inspection



DANGER!
 Risk of serious personal injury and/or damage to air handling unit.
 Read and understand the entire chapter "1.5 General safety messages" before working on, servicing, or inspecting the air handling unit.

1. Shut down the unit via the service switch in the control equipment, safety switch in the 0 position.
2. Wait until the fans have stopped, then open the inspection door.
3. Check that the rotor rotates easily. If it is sluggish, you might have to adjust the bristled sealing strip.
4. Check that the rotor's bristled sealing strip seals against the side plates and that it is not worn. The bristled sealing strip is subject to wear and can be adjusted or replaced if the need arises.
5. Check that the drive belt is properly tensioned and does not slip. If the belt slips, it will have to be shortened. The rotor speed should not be lower than 8 rpm during full energy recovery.
6. Check that the drive belt is intact and clean.
7. Check that the rotor's inlet surfaces are not covered with dust or other impurities. NB: Avoid touching the rotor inlet and outlet surfaces with your hands or tools.
8. Check the pressure balance:

For design Home Concept, the trim damper ETET/TR regulates the pressure balance automatically against the set value in the controller unit. Check that the measured pressure balance between measurement tappings P2 and P3 corresponds to the set pressure balance setpoint in the controller unit (-10 Pa).

Example:

Measurement outlets for P2: Downstream supply air fan (SF) generates negative pressure in relation to the atmospheric pressure (atm), e.g. -100 Pa

Measurement outlets for P3: Downstream extract air fan (EF) and trim damper generate greater negative pressure than at P2, e.g. -110 Pa.

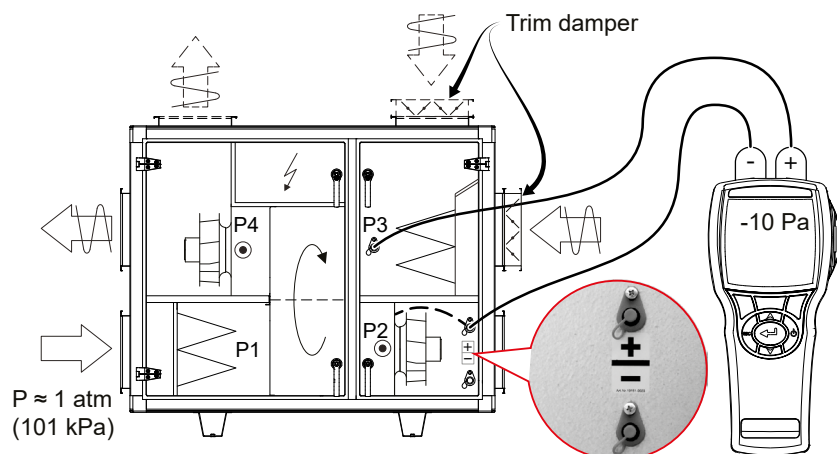

For the standard version: To ensure correct function of the purging sector, the negative pressure at P3 should be greater than the negative pressure at P2 (min. diff. 25 Pa). Otherwise an ETET-TR trim damper can be used on the extract air side in order to throttle in the correct pressure balance.

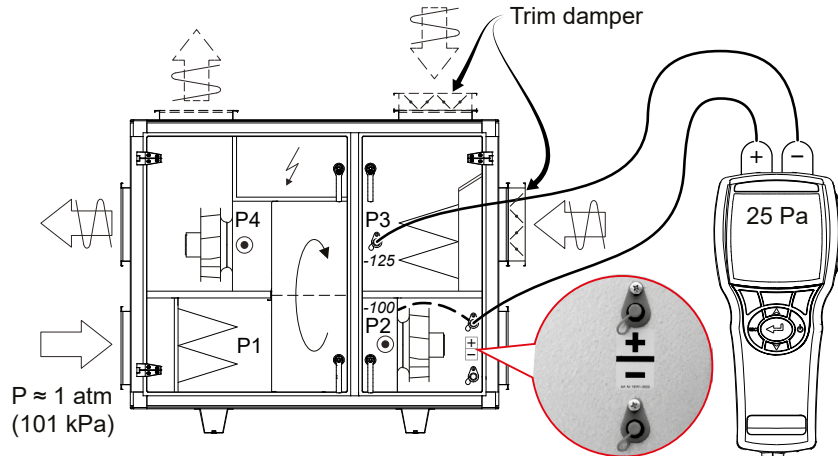

9. Check the differential pressure across the rotor. The purging sector is factory-installed, set to the maximum open position. Depending on the unit's pressure difference across the rotor, the purging sector may need adjustment. An incorrect setting may impair the efficiency. Inspection and adjustment should be carried out as follows:
 - Measure and write down the differential pressure between the outdoor air (P1) and the extract air (P3).

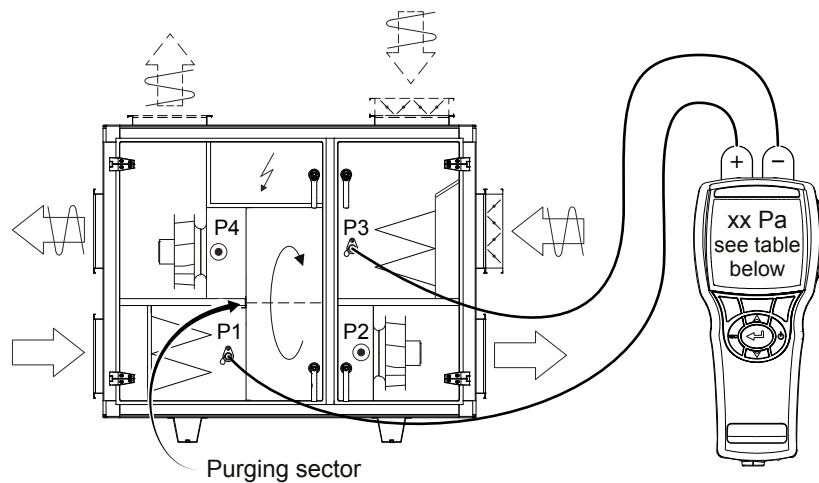

- Read the recommended setting (adjustment hole in the purging sector) from the table below.

	Rotor variant	Adjustment hole in the purging sector		
		3 open*	2 intermediate position	1 closed
Diff. pressure between P1 and P3 (Pa)	R20, R30, R40, NO, NE, HY, HE, EX	< 300	> 300	-
	R50, R60, NP, NX, HP	< 400	> 400	-

*maximum open purge sector, preset position from the factory

- Adjust the purging sector if the need arises. The illustration shows the purging sector set to the maximum open position.

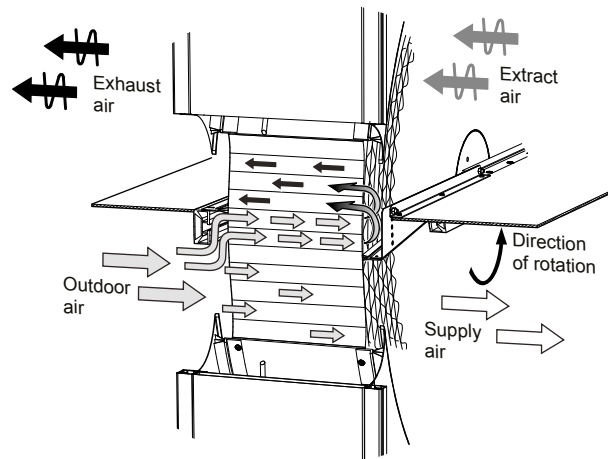

Schematic diagram - sizes and model may vary.

Cleaning



DANGER!

Risk of serious personal injury and/or damage to air handling unit.

Read and understand the entire chapter "1.5 General safety messages" before working on, servicing, or inspecting the air handling unit.

- Remove dust by carefully vacuum cleaning using a soft brush.
- In the event of stubborn and heavy-duty dirt, the rotor can be sprayed with a mild, alkaline detergent.
- Compressed air at low pressure (max. 6 bar) can be used for blowing the surfaces clean. To avoid damage, the nozzle should not be held any closer to the rotor than 5–10 mm.

A hygroscopic rotor variant can absorb particles which in some cases give off odours. To prevent odours arising, exercise run the hygroscopic rotor using the integrated control function. If an odour persists, we recommend cleaning the rotor with a mild, alkaline detergent.

Lubrication

The bearings and drive motor are permanently lubricated and do not require additional lubrication.

6.4 Air heater water (ECET-VV) and Thermoguard (ECET-TV)

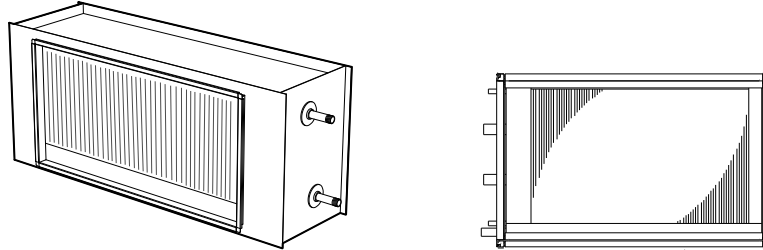

Air heater water (code ECET-VV) and Thermoguard air heater water (code ECET-TV)

The heating coil consists of a number of copper tubes with aluminium fins pressed on them. The coil will have impaired capacity if dust forms a coating on the coil surfaces. Not only does this impair the heat transfer capacity of the coil, it also increases the pressure drop on the air side.

Even if the ventilation system is fitted with high quality filters, as time passes dust deposits will form on the front edges of the coil fins (at the inlet side). To utilise its full capacity, the coil must be well vented. The pipework should be vented by opening the bleeder screws in pipe connections and/or an air vessel.

Inspection

	<p>DANGER! Risk of serious personal injury and/or damage to air handling unit. Read and understand the entire chapter "1.5 General safety messages" before working on, servicing, or inspecting the air handling unit.</p>
---	---

Check:

1. The coil fins to detect possible mechanical deformity
2. That the water coil is not leaking.

Cleaning

	<p>DANGER! Risk of serious personal injury and/or damage to air handling unit. Read and understand the entire chapter "1.5 General safety messages" before working on, servicing, or inspecting the air handling unit.</p>
---	---

If the fins on the coil are dirty, vacuum clean from the inlet side. Alternatively, you can blow them clean with compressed air from the outlet side. In the event of stubborn dirt, use a mild, alkaline detergent.

Bleeding



DANGER!
 Risk of serious personal injury and/or damage to air handling unit.
 Read and understand the entire chapter "1.5 General safety messages" before working on, servicing, or inspecting the air handling unit.

Bleed the heating coil and the pipework if needed. Bleeder screws are on top of the coil or on the tube connections.

Function



DANGER!
 Risk of serious personal injury and/or damage to air handling unit.
 Read and understand the entire chapter "1.5 General safety messages" before working on, servicing, or inspecting the air handling unit.

Check that the coil is radiating heat. This can be done by temporarily increasing the temperature setting (setpoint).

Additional maintenance for Thermoguard (code ECET-TV)



DANGER!
 Risk of serious personal injury and/or damage to air handling unit.
 Read and understand the entire chapter "1.5 General safety messages" before working on, servicing, or inspecting the air handling unit.

1. The ThermoGuard coil must be fitted with a safety valve, the function of which should be checked regularly (at least once a year). If you see that the valve is leaking, this is normally due to impurities from the pipe system that have accumulated on the valve seat.
 In normal cases, it is sufficient to carefully turn the valve knob and in this way "flush" the valve seat clean. If the safety valve continues to leak, you will have to replace it with a new one of the same type and with the same opening pressure.
2. Any shut-off valves on the supply or return lines may not be closed if freezing temperatures are likely.
3. If a Thermoguard coil has frozen, let it thaw completely before restarting operation. If the heat recovery unit is installed upstream of the coil, it is often sufficient to run heat recovery to thaw the coil. If this does not work, some other external heating source will have to be used for thawing the water coil.



NB!
 To ensure correct ThermoGuard coil function, the entire coil must be allowed to thaw before returning it to full operation. Make sure that water is circulating in the entire coil when you start it up.

6.5 Air heater electric (code ECET-EV)

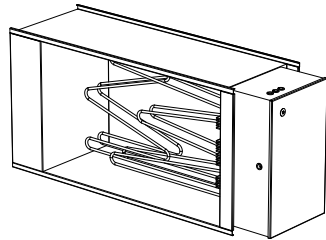

Air heater electric (code ECET-EV)

The heating coil consists of unshathed electric heating rods. A substantial accumulation of dust or other impurities on the heating rods will cause them to overheat. This could shorten their service life. This might also entail an odour of burnt dust and, in the worse case, the risk of fire. Overheated electric heating rods may become deformed or loosen from their suspension fasteners and heat the air unevenly.

Inspection

	<p>DANGER! Risk of serious personal injury and/or damage to air handling unit. Read and understand the entire chapter "1.5 General safety messages" before working on, servicing, or inspecting the air handling unit.</p>
--	---

Check that the electric heating rods are correctly positioned and that they are not deformed in any way.

Cleaning

	<p>DANGER! Risk of serious personal injury and/or damage to air handling unit. Read and understand the entire chapter "1.5 General safety messages" before working on, servicing, or inspecting the air handling unit.</p>
---	---

Vacuum and/or wipe all surfaces with a cloth.

Function

**DANGER!**

Risk of serious personal injury and/or damage to air handling unit.

Read and understand the entire chapter "1.5 General safety messages" before working on, servicing, or inspecting the air handling unit.

1. Simulate reduced required output by temporarily lowering the temperature setting (setpoint), so that all the electric output steps (contactors) switch out.
2. Then sharply increase the setpoint setting and check that the electric output steps switch in.
3. Restore the temperature setting.
4. Shut down the unit via the service switch in the control equipment, safety switch in the 0 position.
5. All the electric output steps should switch out (i.e. the contactors in the OFF position). Stopping the unit may be delayed approx. 2–5 minutes to allow the fans to cool the heat energy stored in the air heater.

The electric heater is equipped with dual temperature limiters. The one that re-sets itself automatically should be set to 70°C.

The overheat protection with manual reset interrupts operation when the heater reaches approx. 120°C and is located on the cover panel on the side of the heater. **Determine the cause of overheating and take corrective action before you reset the protection device.**

Please note that the risk of overheating increases as the air flow through the unit decreases. The air speed should not be lower than 1.5 m/s.

6.6 Air cooler water (code ECET-VK) and Air cooler for direct expansion (code ECET-DX)

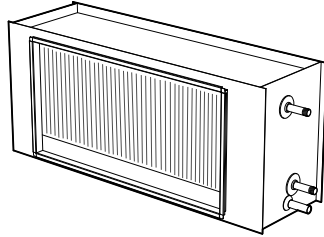

Air cooler water (code ECET-VK)

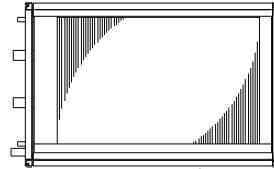

Air cooler for direct expansion (code ECET-DX)

The cooling coil consists of a number of copper tubes with aluminium fins pressed onto them. The coil will have impaired capacity if dust forms a coating on the coil surfaces.

Not only does this impair the heat transfer capacity of the coil, it also increases the pressure drop on the air side.

Even if the ventilation system is fitted with high quality filters, as time passes dust deposits will form on the front edges of the coil fins (at the inlet side). A drip tray with drain is located under the cooling coil for collecting and removing evaporation water.

Inspection

	<p>DANGER! Risk of serious personal injury and/or damage to air handling unit. Read and understand the entire chapter "1.5 General safety messages" before working on, servicing, or inspecting the air handling unit.</p>
---	---

Check:

1. The coil fins to detect possible mechanical deformity
2. That the water coil is not leaking
3. That cooling energy is uniformly distributed across the coil surfaces (in operation)
4. The drip tray and drain with water trap (clean if necessary)
5. That the water trap (without non-return valve) is filled with water.

Cleaning



DANGER!
Risk of serious personal injury and/or damage to air handling unit.
Read and understand the entire chapter "1.5 General safety messages" before working on, servicing, or inspecting the air handling unit.

If the fins on the coil are dirty, vacuum clean from the inlet side. Alternatively, you can blow them clean with compressed air from the outlet side. In the event of stubborn dirt, use a mild, alkaline detergent.

Bleeding (only applies to ECET-VK)



DANGER!
Risk of serious personal injury and/or damage to air handling unit.
Read and understand the entire chapter "1.5 General safety messages" before working on, servicing, or inspecting the air handling unit.

Bleed the cooling coil and the pipe connections if needed. Bleeder screws are on top of the coil or on the tube connections.

Function



DANGER!
Risk of serious personal injury and/or damage to air handling unit.
Read and understand the entire chapter "1.5 General safety messages" before working on, servicing, or inspecting the air handling unit.

Check that the coil is emitting cooling energy. This can be done by temporarily lowering the temperature setting (setpoint). Note that cooling is blocked when the outdoor temperature drops below the set value for cooling start.

6.7 Fan unit

The purpose of the fans is to transport air through the system, i.e. the fan must overcome the flow resistance in air terminals, air ducts and the unit.

The fan speed is regulated to provide correct air flow. If the fans generate a lower air flow, this will impair the function of the ventilation system.

- If the supply air flow is too low, the system will be out of balance, causing poor room climate.
- If the extract air flow is too low, the ventilation capacity will be unsatisfactory. Imbalance may also force moist air out into the building structure. One reason why the fans are generating too little air flow may be that impurities have collected on the fan impeller blades.

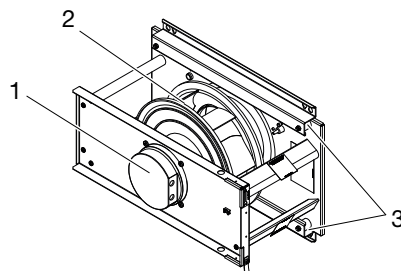

Fan unit, sizes 04 and 06

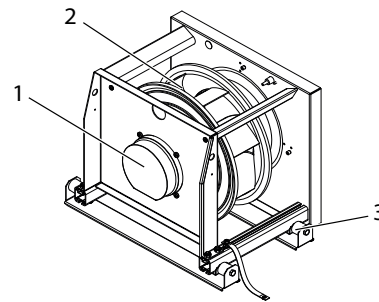

Fan unit, sizes 10 and 16

1. EC motor with control unit
2. Fan impeller
3. Anti-vibration mounting

Inspection

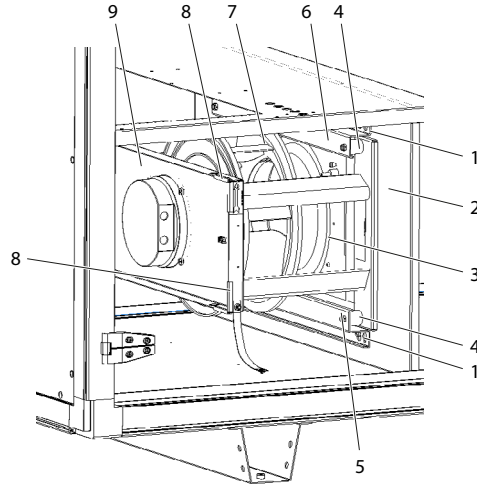

Example fan unit size 04-06

1. Screws suspension
2. Connection plate
3. Inlet cone
4. Anti-vibration mounting
5. Anti-vibration support lower
6. Anti-vibration support upper
7. Fan impeller with motor
8. Edge cover
9. Fan support, upper

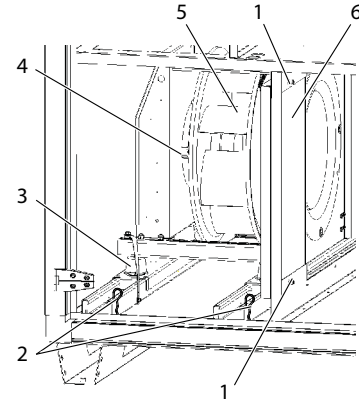

Example fan unit size 10-16

1. Screws side cover
2. Pins
3. Anti-vibration mounting
4. Motor
5. Fan impeller
6. Side cover



DANGER!
Risk of serious personal injury and/or damage to air handling unit.
Read and understand the entire chapter "1.5 General safety messages" before working on, servicing, or inspecting the air handling unit.

1. Remove one end of the fan assembly's earth braid. If necessary, split the motor cable's quick connector.
For size 04-06: Remove the screws (position 1) in the connection plate (position 2) and unhook the fan unit from the key holes in the anti-vibration supports (position 5 and 6), both upper and lower.
For size 10-6: Remove the screws (position 1) and the pins (position 2). Remove the side cover (pos 6). Pull out the fan units (fan and motor are mounted on slide rails).
2. Check that the fan impeller rotates easily, is in balance and does not vibrate. Also check that the fan impeller is clean from any accumulation of particles. Imbalance may be due to a coating or damage to the fan impeller blades.
3. Listen to the sound from the motor bearings. If the bearings are in good condition, you will hear a slight purring sound. A scraping or pounding sound may mean that the bearings are damaged and service is then required.

4. **For size 04-06:** Check that the fan impeller with motor (position 7) is firmly mounted in the upper fan support (position 9) and that it has not shifted sideways toward the inlet cone (position 3). Also check to make sure that the inlet cone is properly secured. Check that the anti-vibration mountings (position 4) are intact and are firmly fitted.
5. **For size 10-16:** Fan impeller (pos 5) and motor (pos 4) are mounted on a frame equipped with anti-vibration mountings. Check that the anti-vibration mountings (position 3) are intact and are firmly fitted.
6. **For size 04-06:** Make sure the edge cover (pos 8) on the fan support upper (pos 9) sits firmly.
7. Check the mounting bolts, screws as well as the suspension devices and support.
8. Check that the gasket on the connection plate around the connection opening is intact and is firmly fitted.
9. Check that the measurement tubes are securely fitted on each measurement outlet.
10. Remount the fan units.
11. Check the air flows by:
 - reading the flow display on the Climatix display unit for units with control equipment (code MX).
 - measuring Δp in the connections (measurement outlets) for flow measurement +/- for units without control equipment (code UC, MK, US).

Use the unit's air flow label and see which flow corresponds to the measured Δp .

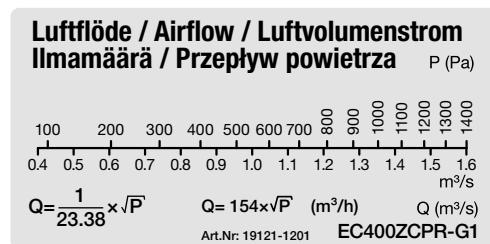

Example of air flow label

Cleaning



DANGER!
Risk of serious personal injury and/or damage to air handling unit.
Read and understand the entire chapter "1.5 General safety messages" before working on, servicing, or inspecting the air handling unit.

1. Follow item 1 under *Inspection*.
2. Wipe the fan impeller blades to remove any coatings. Use a mild alkaline detergent.
3. The external surfaces of the motor must be kept clean from dust, dirt and oil. Clean with a dry cloth. In the event of stubborn dirt, use a mild alkaline detergent. The motor is likely to overheat inside if thick layers of dirt prevent air from entering the motor to cool the stator structure.
4. Vacuum clean the air handling unit so that particles will not be blown out into the duct system.
5. Clean the other parts in the same way as the fan impellers. Check that the inlet cones are securely mounted.
6. Follow item 10-11 under *Inspection*.

6.8 Damper (code ECET-UM, ECET-TR)

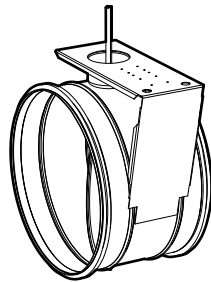

Size 04

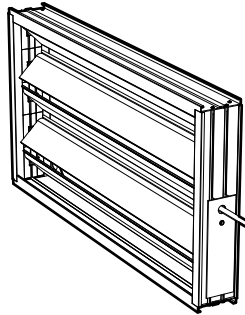

Sizes 06, 10 and 16

The purpose of the dampers is to regulate the air flow. Faulty function gives rise to disturbances that may result in serious problems.

- If the damper does not open fully, the air flow is reduced.
- If the damper leaks, this will result in increased energy use.
- If the trim damper for the rotor purging function is not working or is incorrectly set, it may result in odours from the extract air being transferred to the supply air via the rotor.
- If the damper is placed on the outdoor air side and does not close completely when the unit stops, the heating coil may freeze.

Units that are supplied with integrated control equipment are equipped with the pressure-controlled rotor purging function control function in order to optimise the trim damper function and minimise the risk of transferring odour.

Inspection

	<p>DANGER! Risk of serious personal injury and/or damage to air handling unit. Read and understand the entire chapter "1.5 General safety messages" before working on, servicing, or inspecting the air handling unit.</p>
---	---

1. Check the function of the damper actuator.
2. Check the dampers for tightness when they are closed. If they are not sealed, adjust the damper actuator to make the dampers tight (does not apply to trim dampers).
3. Check the sealing strips.
4. If the damper is not working, check that there are no screws penetrating the drive mechanism/damper blades to interfere with damper function.

Cleaning

	<p>DANGER! Risk of serious personal injury and/or damage to air handling unit. Read and understand the entire chapter "1.5 General safety messages" before working on, servicing, or inspecting the air handling unit.</p>
---	---

Clean the damper blades with a cloth. In the event of stubborn dirt, use a mild, alkaline detergent.

6.9 Sound attenuator (code ECET-LD)

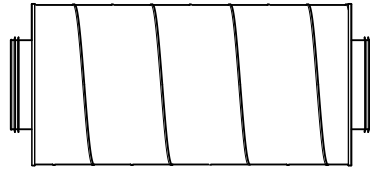

Size 04

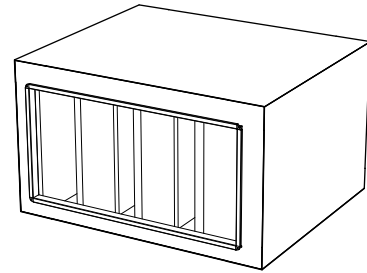

Sizes 06, 10 and 16

The function of the sound attenuator is to reduce the sound level in the system.

Inspection



DANGER!
 Risk of serious personal injury and/or damage to air handling unit.
 Read and understand the entire chapter "1.5 General safety messages" before working on, servicing, or inspecting the air handling unit.

Check that the baffle elements are intact and have clean surfaces. Take action if necessary.

Cleaning



DANGER!
 Risk of serious personal injury and/or damage to air handling unit.
 Read and understand the entire chapter "1.5 General safety messages" before working on, servicing, or inspecting the air handling unit.

Vacuum and/or wipe all surfaces with a damp cloth. In the event of stubborn dirt, use a mild, alkaline detergent.

6.10 StarCooler cooling unit (code ACEC)

General

The cooling unit has been designed and fabricated along given operation parameters that must be met in order for the unit to operate optimally and provide good operating economy. The operation parameters must not be changed unless a check is first made to ascertain that the changes will be within the unit's operating range.

Leakage inspection and registration

For information on the operator's responsibility with regards to leakage inspection and registration, see "2.6 Handling of refrigerant" page 8.

Visual check

	<p>DANGER! Risk of serious personal injury and/or damage to air handling unit. Read and understand the entire chapter "1.5 General safety messages" before working on, servicing, or inspecting the air handling unit.</p>
---	---

Check:

1. The fins on the condenser and evaporator to detect mechanical deformations
2. The drip tray and drain with water trap (clean if necessary)
3. That the water trap (without non-return valve) is filled with water.

Cleaning

	<p>DANGER! Risk of serious personal injury and/or damage to air handling unit. Read and understand the entire chapter "1.5 General safety messages" before working on, servicing, or inspecting the air handling unit.</p>
---	---

If the fins on the batteries are dirty, clean them by vacuuming from the inlet side, or carefully blow them clean with compressed air from the outlet side. In the event of stubborn dirt, use a mild, alkaline detergent.

Function

	<p>DANGER! Risk of serious personal injury and/or damage to air handling unit. Read and understand the entire chapter "1.5 General safety messages" before working on, servicing, or inspecting the air handling unit.</p>
---	---

Check that the cooling unit operates as it should by temporarily lowering the temperature setting (setpoint). Note that cooling is blocked during weak air flow or when the outdoor temperature drops below the set value for cooling start.

7 Troubleshooting

7.1 StarCooler cooling unit (code ACEC)

Troubleshooting via symptoms

Symptom	Possible cause	Corrective action
Low cooling power – too high temperature in the cooled object/medium	The power supply has been interrupted	Check the control/safety switches and fuses
	None or too low air flow across evaporator	Check that nothing inhibits the air flow
	The thermostat/control equipment is incorrectly set/defective	Adjust the settings or replace the equipment
	The capacity controller is set for too-high initial pressure	Turn the opening screw anti-clockwise 1/6 turn at a time; read the temperature change after 5 minutes, and so forth. See the figure below.
	Compressor is not operating	See symptom “Compressor is not operating”
	The rotor runs in cooling recovery	Turn off the cooling recovery function
Compressor is not operating	The power supply has been interrupted	Check the control/safety switches and fuses
	Compressor has opened a safety circuit	Check and reset, if needed
	Defective compressor	Check/replace
The low pressure control switches out the compressor	Insufficient refrigerant volume	The cooling system has a leak. Find the leak and seal it. Add more refrigerant.
	No or too low air flow across the evaporator	Check the air flow
	Expansion valve is defective	Check/replace
	The low pressure control is defective	Check/replace
The high pressure switch switches out the compressor	None or too low air flow across condenser	Check the air flow across the condenser Make sure that the external fire damper exercise cycle interlocks the unit (if selected)
	The high pressure switch is defective	Inspect, replace
Frost on the evaporator	The expansion valve is incorrectly preset/defective	Check/replace
	Insufficient refrigerant volume	Look for leakage, seal the leak and top up with refrigerant
	Low supply air flow	Adjust the air flow



Air handling with focus on LCC

You are welcome to contact us

Switchboard:	+46 (0)47 075 88 00	
Control support:	+46 (0)47 075 89 00	styr@ivprodukt.se
Service:	+46 (0)47 075 89 99	service@ivprodukt.se
Spare parts:	+46 (0)47 075 88 00	spareparts@ivprodukt.com
Visit us at:	www.ivprodukt.com	
Documentation for your unit:	docs.ivprodukt.com	
Technical documentation:	docs@ivprodukt.se	