

---

# Operation and Maintenance

## Envistar Top



Order number:  
Project:



# Unit specifications

## Unit type

TEM

TXM

TER

TXR

TEC  1V  2V

TTC

Home Concept Version

## Unit parts and accessories

Rotary heat exchanger TXRR

Counter-flow exchanger TXMM

Air heater water ETAB-VV Output var  
1  2  3

ThermoGuard ETAB-TV  
Output var. 1  2

Air heater electric ETAB-EV  
Output var. 1  2  3

Air heater electric ETKB-EV Output var.  
1  2  3  4

Air cooler water ETKB-VK

Damper ETSP-UM, ETSP-TR, ETRL

Sound attenuator ETLD

## Size

04  06  09  10

12  16  21

## Control equipment

MX

UC

MK

US

HS

## Filter supply air

ePM10-60% / M5

ePM1-50% / F7

Excl. filter

## Filter extract air

ePM10-60% / M5

ePM1-50% / F7

Excl. filter



# Table of Contents

<b>1 Safety precautions</b>	
1.1 Lockable safety switch .....	5
1.2 Inspection doors .....	5
1.3 Electrical connection .....	5
1.4 Cooling unit/Reversible heat pump .....	5
<b>2 General</b>	
2.1 Intended use .....	6
2.2 Manufacturer .....	6
2.3 Designations .....	6
2.4 CE marking and EU Declaration of Conformity .....	7
2.5 Maintenance .....	7
2.6 Handling of refrigerant .....	8
2.7 Extended warranty .....	9
2.8 Spare parts .....	9
2.9 Dismantling and decommissioning .....	9
<b>3 Technical description</b>	
3.1 Envistar Top air handling unit .....	10
3.2 Home Concept model .....	10
3.3 EcoCooler cooling unit (code TEC) .....	11
3.4 Reversible heat pump ThermoCooler HP (code TTC) .....	14
<b>4 Wiring instructions and fuse protection</b>	
4.1 MX – Complete control equipment and UC – Complete electrical connection to terminal without controller unit ...	17
4.2 MK – Fans and heat exchangers electrically connected to terminal .....	18
4.3 HS, US - Without control and without electrical connection .....	18



# Table of Contents, cntd

## 5 Operation

5.1 Hygiene inspection .....	20
5.2 Actions in case of standstill .....	20
5.3 Commissioning .....	21
5.4 Cooling Status – Cooling unit (code TEC), size 04 .....	22
5.5 Cooling Status – Cooling unit (code TEC), size 06-12 .....	25
5.6 Cooling Status – Cooling unit, size (code TEC) 16-21 .....	27
5.7 Cooling Status - reversible heat pump (code TTC) .....	29

## 6 Maintenance instructions

6.1 Service schedule .....	31
6.2 Filters (code ELEF) .....	33
6.3 Rotary heat exchanger (code TXRR) .....	36
6.4 Counter-flow exchanger (code TXMM) .....	41
6.5 Air heater water (code ETAB-VV) and Thermoguard (ETAB-TV) .....	43
6.6 Air Heater electric (Code ETAB-EV, ETKB-EV, ETAB-SV) .....	45
6.7 Air cooler water (code ETKB-VK) .....	46
6.8 Fan unit (code ELFF) .....	47
6.9 Damper (code ETSP-UM, ETSP-TR, ETRL) .....	50
6.10 Sound attenuator (code ETLD) .....	51
6.11 Cooling unit (code TEC) and reversible heat pump (code TTC) .....	52

## 7 Alarm management and troubleshooting

7.1 Cooling unit (code TEC) - size 04 and 16-21 .....	53
7.2 Cooling unit (code TEC) - size 06-12 .....	55
7.3 Reversible heat pump (code TTC) .....	59



# 1 Safety precautions

Observe warning labels on the unit as well as the following safety precautions:

## 1.1 Lockable safety switch



**WARNING!**

High voltage, risk of personal injury.

Working on/servicing the unit – Shut down the unit via the service switch in the control equipment, then turn the safety switch to the 0 position and lock it.

**NB:**

The safety switch is not designed for starting/stopping the unit. Always use the control equipment to start and shut down the unit.

## 1.2 Inspection doors



**WARNING!**

Positive pressure inside the unit, risk of personal injury.

Allow the pressure to drop before you open the inspection doors.



**WARNING!**

Rotating fan impeller, risk of personal injury. Shut down the unit via the service switch in the control equipment, then turn the safety switch to the 0 position and lock it. Wait at least 3 minutes before opening inspection doors.

**NB:**

The doors in front of moving parts should normally be locked; there are no safety guards. Before carrying out work, unlock the doors with the key provided.

## 1.3 Electrical connection



**WARNING!**

Rotating fan impeller, risk of personal injury. The unit must not be energised until all ducts have been connected.

**NB!**

Wiring of connections and other electrical work may only be carried out by a qualified electrician or by service personnel recommended by IV Produkt.

## 1.4 Cooling unit/Reversible heat pump



**WARNING!**

Hot surfaces, risk of personal injury. Shut down the unit via the service switch in the control equipment, then turn the safety switch to the 0 position and lock it. Wait at least 30 minutes before opening the compressor inspection doors.

## 2 General

### 2.1 Intended use

The air handling units in the Envistar Top series are intended for comfort ventilation in buildings.

When installed indoors, the air handling unit must be installed in an area that maintains a temperature between +7 and +30°C, and with a moisture content of <3.5 g/kg in the fan room in winter. The unit can also be equipped for outdoor installation.

Any other use and installation in other environments is prohibited unless specifically permitted by IV Produkt AB.

### 2.2 Manufacturer

The Envistar air handling units (AHUs) are manufactured by:

IV Produkt AB  
 Sjöuddevägen 7  
 SE-350 43 VÄXJÖ

### 2.3 Designations

The unit and cooling unit/reversible heat pump (if selected) have a model type plate affixed to the front.

The model type plate shows the series number and the requisite designations to identify the unit.

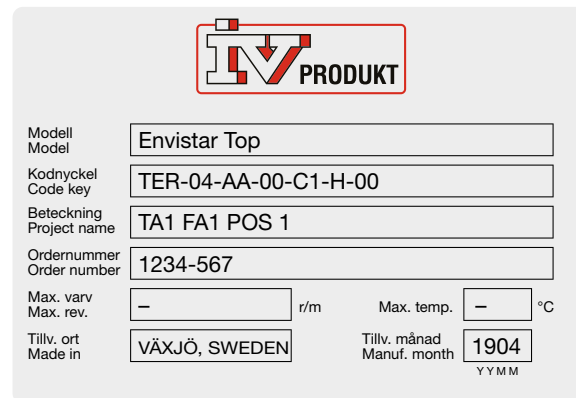

The image shows a typical model identification label for an Envistar Top air handling unit. At the top center is the IV PRODUKT logo. Below it, the label contains the following information:

Modell Model	Envistar Top		
Kodnyckel Code key	TER-04-AA-00-C1-H-00		
Beteckning Project name	TA1 FA1 POS 1		
Ordernummer Order number	1234-567		
Max. varv Max. rev.	—	r/m	Max. temp. — °C
Tillv. ort Made in	VÄXJÖ, SWEDEN	Tillv. månad Manuf. month	1904 Y Y M M

*Typical model identification label*

## 2.4 CE marking and EU Declaration of Conformity

The air handling unit and any associated cooling unit or reversible heat pump are CE marked, which means that upon delivery they conform to applicable provisions in EU Machinery Directive 2006/42/EC as well as to other EU directives applicable to the type of air handling unit, e.g. Pressure Equipment Directive PED 2014/68/EU.

As certification confirming that the requirements have been met, we provide an EU Declaration of Conformity, which is available under Documentation at [ivprodukt.docfactory.com](http://ivprodukt.docfactory.com), or under Order Unique Documentation at [docs.ivprodukt.com](http://docs.ivprodukt.com).



Typical CE label for air handling units

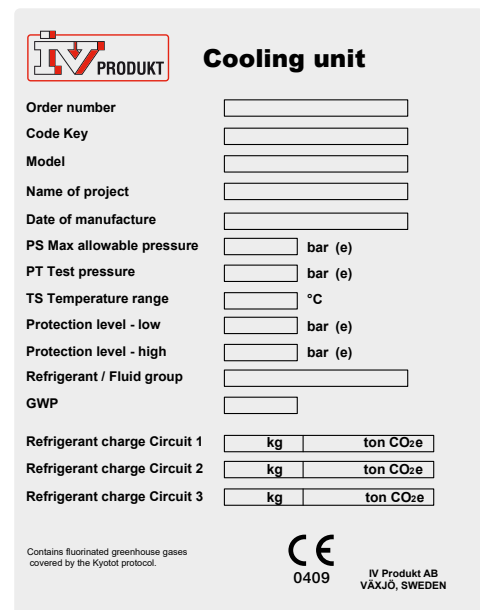

**Cooling unit**

Order number

Code Key

Model

Name of project

Date of manufacture

PS Max allowable pressure  bar (e)

PT Test pressure  bar (e)

TS Temperature range  °C

Protection level - low  bar (e)

Protection level - high  bar (e)

Refrigerant / Fluid group

GWP

Refrigerant charge Circuit 1  kg  ton CO<sub>2</sub>e

Refrigerant charge Circuit 2  kg  ton CO<sub>2</sub>e

Refrigerant charge Circuit 3  kg  ton CO<sub>2</sub>e

Contains fluorinated greenhouse gases covered by the Kyoto protocol.

**CE**  
0409  
IV Produkt AB  
VÄXJÖ, SWEDEN

Typical CE label for cooling units

### For units without integrated control equipment

The EC declaration applies only to units in the condition in which they have been delivered and installed at the facility in accordance with the enclosed installation instructions. The declaration does not include components that were subsequently added or measures subsequently taken on the unit.

## 2.5 Maintenance

The ongoing maintenance of this unit can be carried out either by the person normally in charge of maintaining the building or through a contract with a well-reputed service company.

## 2.6 Handling of refrigerant

The following information summarises the requirements and guidelines for handling the refrigerant used in cooling units. For further information, see the F-gas Regulation (EU/517/2014 on fluorinated greenhouse gases) and the Swedish Refrigerant Regulation (SFS 2016:1128). The purpose of the regulations is to contribute to achieving EU goals for reduced climate impact in accordance with the Kyoto Protocol.

### Operator responsibilities

By operator, we refer to the European Parliament's definition: "...the natural or legal person exercising actual power over the technical functioning of the equipment and systems...".

Generally speaking, the unit operator must:

- Minimise and prevent leakage
- Take corrective action to remedy any leakage that arises
- Ensure that leak inspection, service and repair of the refrigerant circuit are carried out by a certified refrigeration technician
- Ensure that refrigerant is handled in an environmentally secure manner and in accordance with national regulations.

The levels for the various actions to be taken for a system are calculated using carbon dioxide equivalents, CO<sub>2</sub>e (tonnes). This figure is calculated by multiplying the refrigerant's GWP value (Global Warming Potential) by the filling amount in kilos. GWP for R410a is 2088. A filling amount of 1.1 kg R410a therefore corresponds to  $(1.1 \times 2088) / 1000 = 2.30$  CO<sub>2</sub>e(tonnes).

The unit is marked with refrigerant quantity and carbon dioxide equivalent.

### Envistar Top with cooling unit (TEC)

Size	Refrigerant	Refrigerant volume	CO <sub>2</sub> e (tonnes)
04	R410a	1.1 kg	2.30
06	R410a	1.6 kg	3.34
09	R410a	1.9 kg	3.97
10	R410a	1.9 kg	3.97
12	R410a	2.38 kg	4.97
16	R134a	5.0 kg	7.15
21	R134a	5.2 kg	7.44

### Envistar Top with reversible heat pump (TTC)

Size	Refrigerant	Refrigerant volume	CO <sub>2</sub> e (tonnes)
06	R410a	1.75 kg	3.65
09	R410a	2.8 kg	5.85
10	R410a	2.7 kg	5.64
12	R410a	4.1 kg	8.56
16	R410a	4.9 kg	10.23
21	R410a	6.68 kg	13.95



## Leakage inspection and registration

For Envistar Top with cooling unit (TEC) size 16-21 and reversible heat pump (code TTC) size 16-21 the following applies:

- **Leakage inspection** must be carried out by a certified refrigeration technician:
  - When installing/commissioning the unit
  - Periodically at least once per 12 months, i.e. no more than 12 months between inspections
  - Within one month after any work is performed (for example sealing a leak, replacing a component).
- The operator must **record** events, such as the volume and type of refrigerant topped up, refrigerant taken into possession, results of inspections and work done, person and company who carried out service and maintenance.

Envistar Top with cooling unit (code TEC) size 04-12 and reversible heat pump (code TTC) size 06 is not subject to registering or leakage inspection requirements.

## 2.7 Extended warranty

In cases in which the equipment delivered falls under a 5-year warranty, in accordance with ABM 07 with supplement ABM-V 07 or in accordance with NL 09 with supplement VU13, the IV Produkt Service and Warranty Manual is supplied with the product.

In order to lay claim to an extended warranty, a complete, documented and signed IV Produkt Service and Warranty Manual must be presented.

## 2.8 Spare parts

Spare parts and accessories for this unit are ordered from your nearest IV Produkt sales representative. When ordering, state the order number and designation. These are stated on a model type plate, affixed to each component. There is a separate spare parts list for the unit, refer to Order Unique Documentation at [docs.ivprodukt.com](https://docs.ivprodukt.com).

## 2.9 Dismantling and decommissioning

When an air handling unit is to be dismantled, separate instructions must be followed, see [Dismantling and decommissioning the AHU](#) under Documentation at [ivprodukt.docfactory.com](https://ivprodukt.docfactory.com).

## 3 Technical description

### 3.1 Envistar Top air handling unit



*Envistar Top with counter-flow exchanger  
(code TEM)*

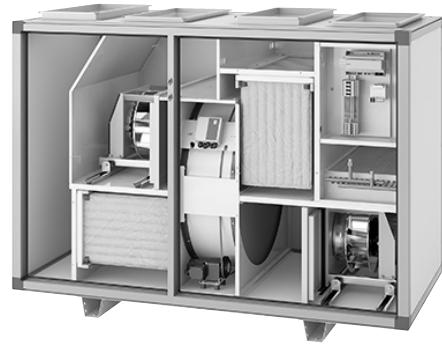

*Envistar Top with rotary heat exchanger  
(code TER)*

Envistar Top is manufactured as a compact unit or modularly, depending on the size and version selected.

The compact unit is supplied complete preassembled from the factory. Modular units are supplied in parts to facilitate transport and entry and are assembled on site

The unit is available in different sizes and in right-hand or left-hand versions. All units have duct connections in the top (up). The units are equipped with either a counter-flow exchanger (code TEM/TXM) or rotary heat exchanger (code TER/TXR).

The units are usually supplied with integrated control equipment, but can also be obtained without control equipment.

### 3.2 Home Concept model

Units with a rotary heat exchanger or counter-flow exchanger in the Home Concept versions have, among other things, specialised control equipment such as automatic defrosting. Units with rotary heat exchangers are also equipped with a pressure balance function for optimal rotor operation.

### 3.3 EcoCooler cooling unit (code TEC)



*Envistar Top with EcoCooler (code TEC) size 10*

The integrated cooling unit with EcoCooler (code TEC) cooling recovery is available as an optional extra to an Envistar Top unit with a rotary heat exchanger. Cooling recovery means that the heat exchanger starts up when the extract air/room temperature drops below the outdoor temperature and cooling is required.

The unit has an electronic expansion valve, rotary compressor size 04, scroll compressor size 06-12 and reciprocating compressor size 16-21.

#### Compressor

Power control takes place with a speed-controlled compressor. When increased cooling is required, the frequency inverter increases the speed of the compressor.

#### Compressor protection

In the event of an alarm initiated by the frequency inverter or the safety circuit, the compressor stops and an alarm indication is given. If the unit is equipped with control equipment, the alarm can be read on the Climatix display.

In the event of an alarm, correct the fault and then reset the alarm. If the safety circuit alarm trips repeatedly, an authorised refrigeration service company must be called in.

##### For size 04-12

The safety circuit consists of a high pressure switch (HP), which protects by tripping when there is high pressure in the system. Use the manual reset button on the pressure switch to perform a reset.

##### For size 16-21

The safety circuit consists of a low pressure control and a high pressure switch with a manual reset button. The safety circuit can trip for two different faults:

- High pressure in the system, HP (manual reset on the pressure switch)
- Low pressure in the system, LP (resets itself automatically)



## Cooling function

For integrated control equipment (MX), the cooling unit is interlocked across the ventilation unit. If any of the fans stop, the cooling unit will also stop. The interlock and demand signal is sent via Modbus.

For external control equipment (US, UC, MK), the interlock signal must be sent via a potential-free relay. The demand signal must be sent via 0–10 V.

The cooling unit has internal communication between the frequency inverter and the expansion valve's control equipment. Communication takes place through the Modbus protocol.

## Circuit board

The circuit board in the cooling unit is internally prewired and tested at the factory.

The circuit board contains:

### Size 04:

Control centre with integrated expansion valve controller

### Size 06-12:

- Compressor inverter
- Expansion valve controller
- Contactor

### Size 16-21:

- Main switch
- Fuse
- Control unit
- Control unit for expansion valve

## Cooling circuit function

A cooling system has four basic components: evaporator, condenser, expansion valve and compressor.

The compressor carries out the work required to run the cooling process. The evaporator is located in the supply air for the unit. The heat from the outdoor air is taken up in this coil, thereby cooling the supply air.

The energy supplied to the cooling system from the evaporator and the compressor leaves the unit via the condenser in the extract air.

It is important to ensure that the air volumes are above the specified minimum flow on both the outdoor air and extract air side. The process cannot work if these air volumes are not available.

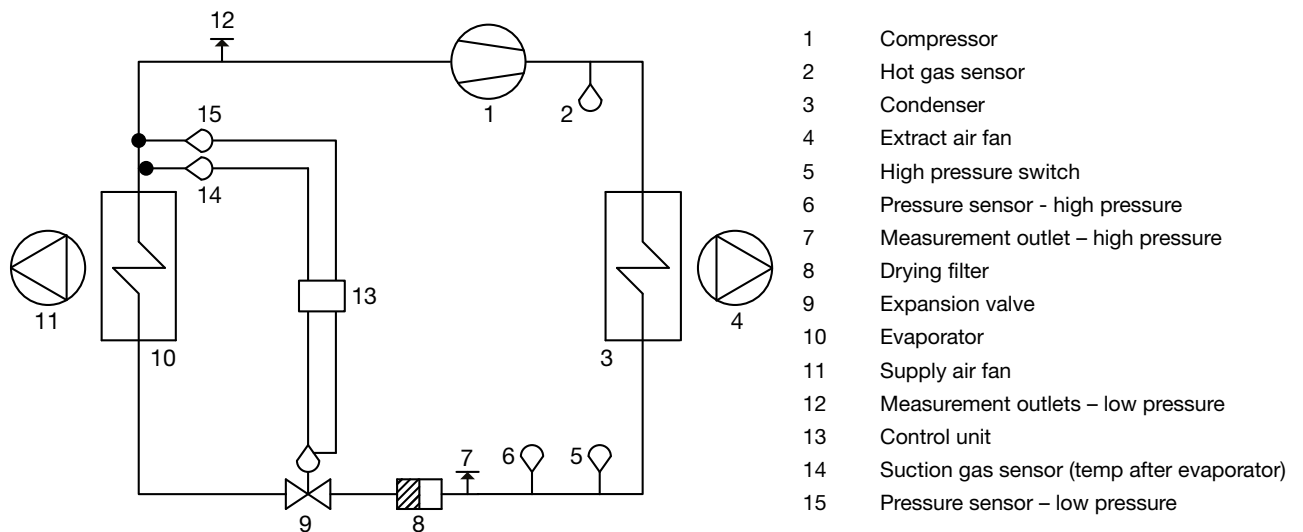

Flow chart for refrigerant system size 04-12

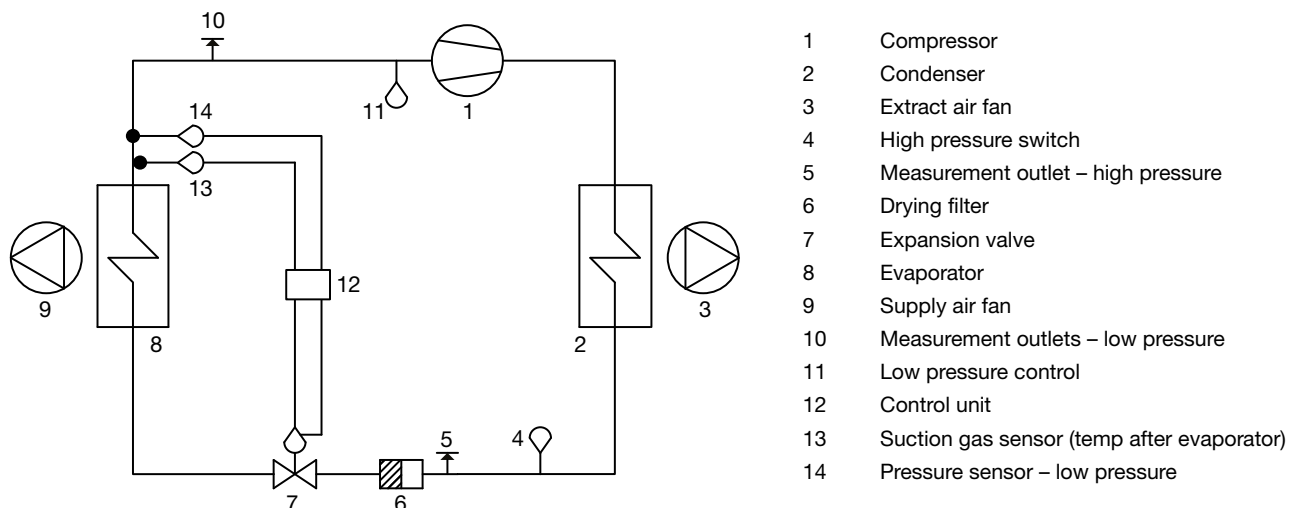

Flow chart for refrigerant system size 16-21

### 3.4 Reversible heat pump ThermoCooler HP (code TTC)



*Envistar Top with ThermoCooler HP (code TTC) size 10*

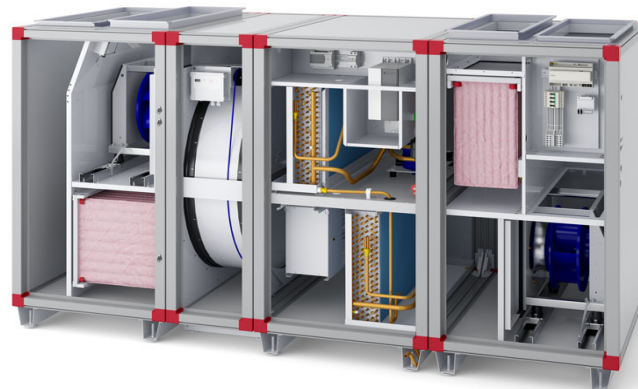

*Envistar Top with ThermoCooler HP (code TTC) Size 12*

The integrated reversible heat pump ThermoCooler HP (code TTC) is available as an optional extra to an Envistar Top unit with a rotary heat exchanger.

The unit has an electronic expansion valve and scroll compressor.

The units are intended to be used to cool or heat supply air in properties.

## Cooling circuit function

The reversible heat pump has four basic components: evaporator, condenser, expansion valve and compressor.

A 4-way valve is used to shift between cooling and heating.

For cooling, the 4-way valve is in cooling mode. For heating, the 4-way valve is in heating mode. This means that the coil, which was a condenser in cooling mode, becomes an evaporator in heating mode. Conversely, the evaporator becomes a condenser.

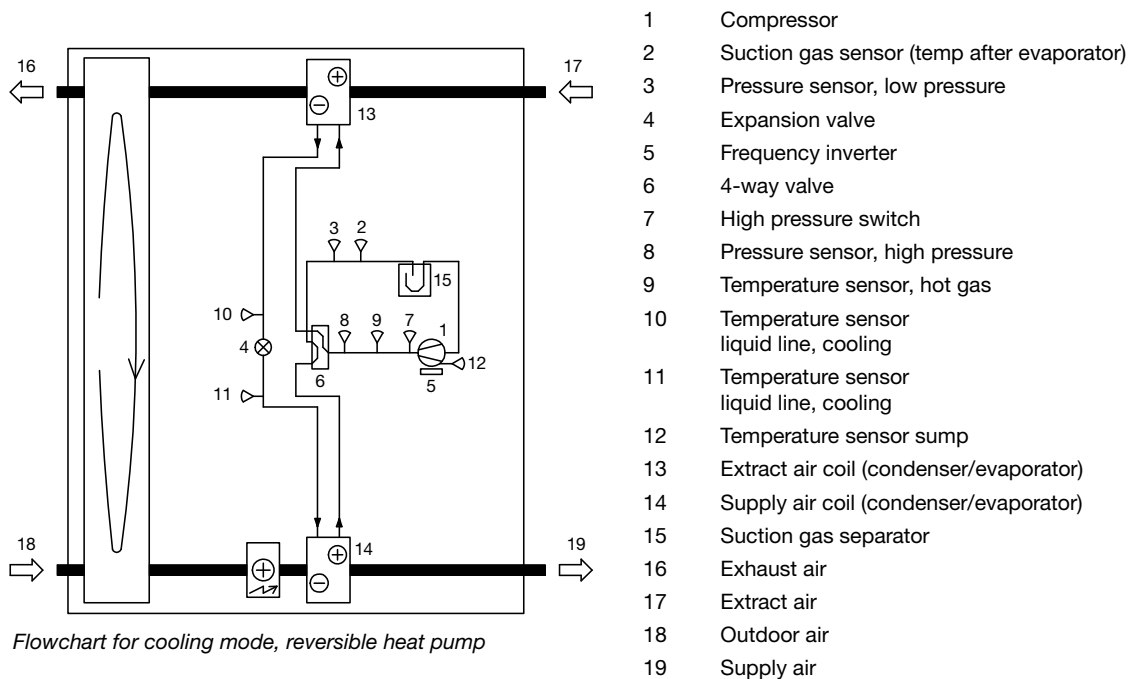

## Cooling mode

The compressor carries out the work required to run the cooling process. The evaporator is located in the supply air for the unit. The heat from the outdoor air is taken up in this coil, thereby cooling the supply air.

The energy supplied to the cooling system from the evaporator and the compressor leaves the unit via the condenser in the extract air.

It is important to ensure that the air volumes are above the specified minimum flow on both the outdoor air and extract air side. The process cannot work if these air volumes are not available.

## Heating mode

The heating pump function takes the heat content of the extract air and reuses it, supplying the same heat to the air handling unit's supply air.

The extract air is the heat pump's energy source. When the extract air meets the extract air coil, it is cooled since the coil functions as an evaporator. From the evaporator, the refrigerant moves to the compressor, where it is compressed. The refrigerant then moves to the supply air coil, where the energy from the extract air and the compressor is released. The energy remaining in the extract air downstream of the heat pump is then recovered in the rotor.



These two recovery systems give a very high degree of efficiency. Since the rotor requires less energy to run than the compressor system, this will be in the first instance. The compressor will only start when the rotor's energy recovery is insufficient to heat the supply air.

## Compressor

Power control takes place with a speed-controlled PM scroll compressor. In the event of an increased power requirement, the frequency inverter will increase the speed of the compressor.

## Compressor protection

In the event of an alarm initiated by the control equipment or the safety circuit, the compressor stops and an alarm indication is given. The alarm can be read on the Climatix display or the Carel unit on the unit's circuit board.

In the event of an alarm, correct the fault and then reset the alarm. If alarm trips repeatedly, an authorised refrigeration service company must be called in.

The cooling/heating pump will primarily trip alarms for the following errors:

- High pressure in the system, manual reset on pressure control HP1
- Low pressure in the system
- Alarm from frequency inverter

## Function

The reversible heat pump is interlocked across the ventilation unit. If any of the fans stop, the cooling/heating pump will also stop. The unit will not start unless the minimum flow is achieved. If a trim heater is installed, the minimum flow must also be reached before start up is permitted.

Heating mode is blocked if the return air temperature does not reach the permitted minimum temperature.

The interlock and demand signal is sent via Modbus.

## Circuit board

The circuit board for the unit contains:

- Main switch
- Fuses
- Control unit

The circuit board is installed inside the unit and is internally prewired and tested at the factory.



## 4 Wiring instructions and fuse protection

### 4.1 MX – Complete control equipment and UC – Complete electrical connection to terminal without controller unit

Applies to:

- Code MX - units supplied prewired with complete, integrated Siemens Climatix control equipment.
- Code UC - units supplied without controller unit but with sensor and damper actuator connected electrically to the terminal block. Fans and heat exchangers are fused and connected electrically to the terminal. The terminal connections are positioned at a shared place in the unit. For further connection to an external process unit, we recommend using a multi-conductor cable.

#### Safety switch

A safety switch must be fitted and wired on each power supply.

#### Wiring diagrams

For wiring diagrams for units with control equipment, see the order-unique wiring diagram supplied with the unit at [docs.ivprodukt.com](https://docs.ivprodukt.com) (Control Diagram).

#### Unit functions, power supply and fuse protection

For recommended fuses, refer to Order Unique Documentation at [docs.ivprodukt.com](https://docs.ivprodukt.com) (Technical Data and Control Diagram), or the product program IV Produkt Designer.

- The unit has a shared power supply for all unit functions as standard, but can be ordered with separate power supplies on special order.
- Electric heaters (air heater electric) have a power supply 3x400 V as standard.  
A special coil or a transformer is required for a 230 V power supply.
- Fuses with type C characteristics are recommended.

## 4.2 MK – Fans and heat exchangers electrically connected to terminal

Code MK - units supplied without control equipment but with fans and heat exchangers connected electrically to terminals.

Connections to terminal blocks are located on each unit section.

For wiring instructions and recommended fuses, refer to Order Unique Documentation at [docs.ivprodukt.com](http://docs.ivprodukt.com) (Terminal Connection and Technical Data).

### Safety switch

A safety switch must be fitted and wired on each power supply.

## 4.3 HS, US - Without control and without electrical connection

- Code HS - for units without control equipment and without electrical connection, control diagrams are available for the heat exchanger and cooling unit under order unique documentation at [docs.ivprodukt.com](http://docs.ivprodukt.com), for other connection instructions, see below.
- Code HS - for units without control equipment and without electrical connection, control diagrams are available for the cooling unit under order unique documentation at [docs.ivprodukt.com](http://docs.ivprodukt.com), for other connection instructions, see below.

Recommended fuse protection refers to fuses with type C characteristics.

### Safety switch

A safety switch must be fitted and wired on each power supply.

## Fans (code ELFF)

Ziehl EC 1x230 V 0.50 / 0.78 kW  
 fan impeller 025 / 028 / 031

Sizes 04, 06, 09 and 10

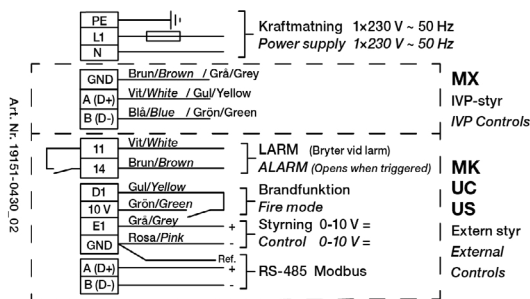

INKOPPLING / WIRING  
 Ziehl 1x230 V - BD

Ziehl EC 1x230 V 1.35 kW  
 fan impeller 031 / 035

Size 10 and 12

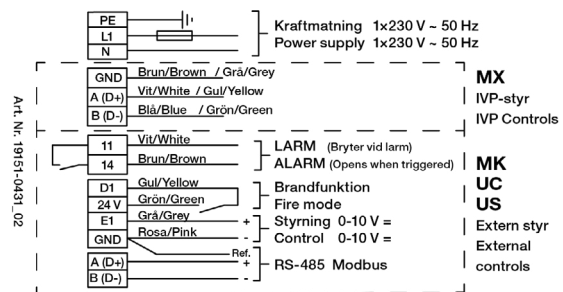

INKOPPLING / WIRING  
 Ziehl 1x230 V - DC

### Ziehl EC 3x400 V 2.40 / 2.90 kW fan impeller 040 / 045

Sizes 16 and 21

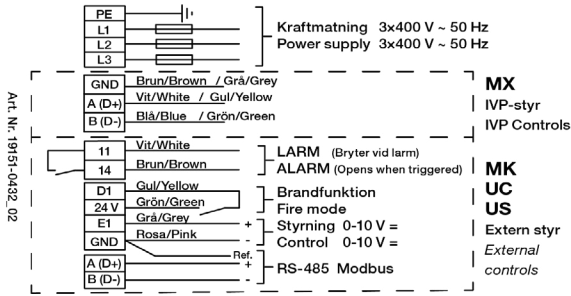

### Rotor operation (Code TXRD)

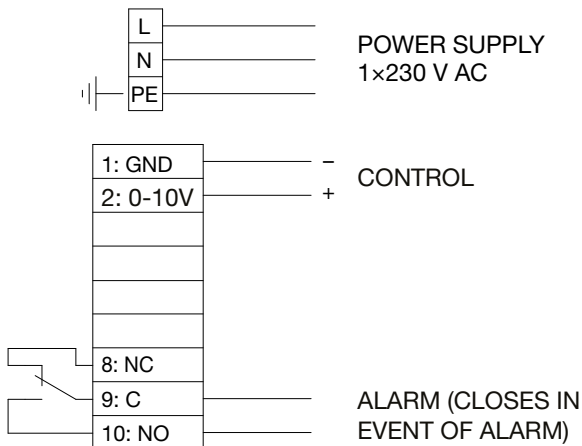

### Air Heater electric (Code ETAB-EV\*, ETKB-EV\*\*)

For power supply, output variant and recommended fuse, refer to Order Unique Documentation at [docs.ivprodukt.com](http://docs.ivprodukt.com) (Technical Data).

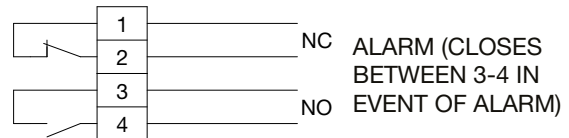
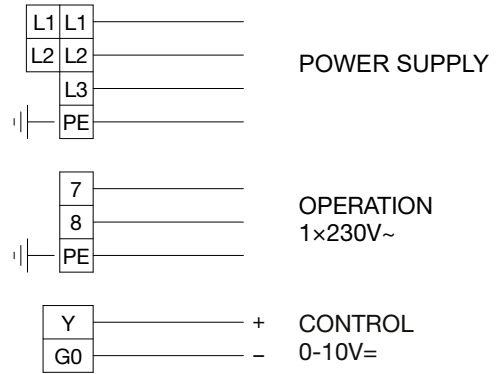

\*For unit mounting, selectable for counter-flow exchanger and rotary heat exchanger.

\*\*For duct mounting, selectable for counter-flow exchanger



## 5 Operation

### 5.1 Hygiene inspection

Envistar Top conforms to guidelines in VDI 6022 Part 1: Hygiene and Hygiene Inspections of HVAC Systems.

For this to apply, a hygiene inspection of the system must be carried out and the system must be cleaned thoroughly as needed before start-up.

For units (code MK, US,UC):

---

**NB!**

**Pressure surges on filters and air ducts must be prevented through the design of the duct system and the settings/configuration of the control system (e.g. gradual start of fans, open damper when the fans are in operation).**

---

### 5.2 Actions in case of standstill

According to guidelines for hygienic design VDI 6022 Part 1:

In case of prolonged standstill in air treatment systems (more than 48 hours), it should be ensured that no moist areas can be found downstream of the cooling coils or humidifier.

In order to avoid the accumulation of moisture – turn off the cooling coils and humidifier in good time and ventilate the air ducts dry (gradual shut-down). Also, be sure to set up or program the required functions in the building's automation/control system for automatic dry blowing of air coolers and downstream sections.

## 5.3 Commissioning

Envistar Top (code TEM, TXM, TER, TXR) and Envistar Top with integrated Eco-Cooler (code TEC) cooling unit or reversible heat pump ThermoCooler HP (code TTC) are factory built units that are tested and documented in the factory.

Commissioning of the unit must be carried out by competent personnel in accordance with the Commissioning Procedure:

- For Envistar Top, refer to [Commissioning Checklist for air handling units](#), which can be downloaded from [ivprodukt.docfactory.com](http://ivprodukt.docfactory.com).
- For Envistar Top with integrated cooling unit, refer to [Envistar Top with EcoCooler, Commissioning Record](#), which can be downloaded from [ivprodukt.docfactory.com](http://ivprodukt.docfactory.com).
- For Envistar Top with integrated reversible heat pump, see [Envistar Top with ThermoCooler HP, Commissioning record](#), which can be downloaded from [ivprodukt.docfactory.com](http://ivprodukt.docfactory.com).

The commissioning procedure applies to units that are supplied with control equipment (code MX).

The validity of the product warranty is conditional on the system having been commissioned correctly. Working on the cooling unit during the warranty period without the approval of IV Produkt shall render the warranty void.

Prior to commissioning, the contractor must:

---

**NB:**

**Wiring of connections and other electrical work may only be carried out by a qualified electrician or by service personnel recommended by IV Produkt.**

---

1. Connect the unit to the power supply via a lockable safety switch.
2. Connect the heating/cooling coil, if relevant.
3. Connect the electrical quick-connectors between the unit parts in a modular design.
4. Installation of the pressure sensor and its hoses.
5. Installation and wiring temperature sensor.
5. Connect all ducts.



**WARNING!**

**Rotating fan impeller. The unit must not be energised until all ducts have been connected.**

---

Follow the troubleshooting instructions in the troubleshooting chart before contacting a service representative for servicing a unit under warranty. This will prevent any unnecessary service calls.



## 5.4 Cooling Status – Cooling unit (code TEC), size 04

### With control equipment (code MX).

Status information is read on the Climatix display.

Information	Value/example	Explanation
Cooling unit status	Unit ON	Normal status for cooling mode if the compressor is running depends on the cooling load.
	OFFbyALR	Switched off caused by alarm.
	OFFbyDIN	Switched off due to interlock. Climatix interlocks cooling operation.
	OFFbyKey	Switched off due to Carel's ON/OFF menu.
	High cond. temp.	The compressor's speed is limited due to high pressure.
Cooling	%	Cooling load sent from Climatix to Carel.
Frequency inverter output	%	
Compr. no		Compressor number, 1 x compressor (C1)
Compr. Sum alarm		
Alarm management		
*****		
Compressor_C1	Off/On	Compressor operating mode.
Suction gas temp_C1	17°C	Measured suction gas temp.
Evaporating temp_C1	10°C	Calculated evaporation temp based on low pressure.
Low pressure_C1	10 bar	Relative pressure from low pressure sensor.
Overheating_C1	7 K	Measured overheating.
Expansion valve_1	80%	Expansion valve position.

**Without control equipment (code UC, MK or US)**

Status information is read on the Carel display (Main menu/Status - I/O).

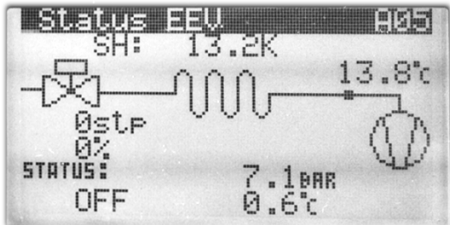
Information	Value/example	Explanation
<b>Status A01</b>		
U6 = Cool.demand:	50%	Cooling load from ventilation control
Remove start delay:	No / Yes	Opportunity to quick start the compressor if Yes is set.
J6 = Modbus Online:	No/Yes	Information about Modbus communication is received.
Modbus command:	Stop/start	Information about command received from Climatix.
Modbus demand:	50%	Information about cooling load received from Climatix.
<b>Status A02</b>		
High Press:	25.00 bar	High pressure
Disch.temp:	50.00°C	Hot gas temperature
Low press:	10.00 bar	Low pressure
Suct.temp:	17.00 °C	Suction gas temperature
<b>Status A03</b>		
U7 = start/stop	Stop	Input for interlock cooling operation
U10 = Alarm reset	No reset	Input to reset alarm
<b>Status A04</b>		
NO6 = General alarm	N/C	Output for sum alarm
<b>Status A05</b>		
		Overheating Suction gas temperature  Valve opening Low pressure Evaporating temperature



Status	A06	Value/example	Explanation
			Cooling load, Output signal, Speed High pressureCondensation temperature Status Hot gas temperature  Suction gas temperature Low pressureEvaporating temperature
<b>Status</b>	<b>A08</b>		
Status		Off/Run/Alarm/Heat	
Current		4.3 Arms	Compressor's power consumption
Voltage		124 Vrms	Power to compressor
Power		0.92 kW	Electrical output used by compressor
DC voltage		391 V	Internal voltage of the inverter
DC ripple		6 V	Variation of internal voltage of the inverter
Drive temp		40.0°C	The inverter's internal temperature
<b>Status</b>	<b>A09</b>		
Working hour			Operating time
Compressor 1		50 h	



## 5.5 Cooling Status – Cooling unit (code TEC), size 06-12

### With control equipment (code MX).

Status information is read on the Climatix display.

Information	Value/example	Explanation
<b>Danfoss-VSD</b>		Danfoss Variable Speed Drive
High pressure	25 bar	Relative pressure from high pressure sensor.
Low pressure	10 bar	Relative pressure from low pressure sensor.
Compressor C1	On/Off	Compressor operating mode.
Cooling unit status	Normal	Status of compressor.
Cooling unit alarm	OK/Alarm	The alarm is displayed when the high pressure switch is tripped. In the event of an alarm, see "High pressure switch alarm" page 58.
Alarm	No/Yes	The alarm is displayed if there is a fault with the inverter or compressor. In the event of an alarm, see "Alarm information for inverter and compressor" page 56.
Safety mode	OK	
VSD restr.	No	The inverter restricts the speed.
Cooling	50%	Cooling load from Climatix cooling regulator.
Compr. frequency	60 Hz	Frequency to the compressor.
Hot gas temp	75°C	Hot gas temperature
*****		
<b>Danfoss-VSD-EEV</b>		Electronic Expansion Valve
Suction gas temp	17°C	Measured suction gas temp.
Evaporation temp	10°C	Calculated evaporation temp based on low pressure.
Overheat. ref	7.0 K	Setpoint for overheating. Adjusted automatically.
Overheating	7.0 K	Measured overheating.
Expansion valve	80%	Expansion valve position.
*****		
<b>Danfoss-VSD-MOC</b>		Motor Orientated Control
Inverter temp	80°C	Internal temperature of the inverter.
Supply voltage	230 V	Supply voltage
C1 Output	2.2 Wa	Compressor output
Int. DC voltage	390 V	Internal DC voltage
Motor current phase A	10.0 A	Power consumption phase A
Motor current phase B	10.0 A	Power consumption phase B
Motor current phase C	10.0 A	Power consumption phase C

## Without control equipment (code UC, MK, US)

Status information is read on the Carel display (Main menu/Status - I/O).

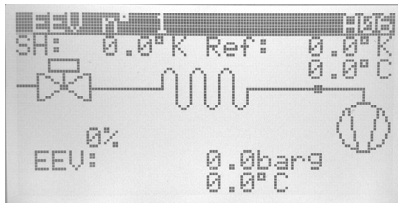
Information	Value/example	Explanation
<b>Status A01</b>		
Compressor:	Off 60.0 Hz	Compressor frequency.
Drive status:	Compressor Off	Status of compressor.
Derating status:	Normal, inactive	Restriction of the maximum frequency due to pressure/temp. ratio.
<b>Status A02</b>		
B1=Cool.demand:	50.0%	The cooling demand signal based on 0–10 V input.
B3=Ambient:	21.7°C	Compressor's ambient temp. (extract air)
High pressure:	25 bar	High pressure (relative)
Discharge:	75°C	Hot gas
<b>Status A03</b>		
Inverter temp:	60°C	Internal temp. of the inverter.
Voltage supply:	230 V	Supply voltage to inverter (1 phase).
Voltage DClink:	390 V	Internal DC voltage of the inverter.
Compressor power:	2200 W	Electrical power use.
Compressor current:	10.0 10.0 10.0 A	Compressor current.
<b>Status A05</b>		
NO1=Compressor:	O	Relay status of operating indication.
NO2=Global alarm:	C	Relay status of alarms.
<b>Status A06</b>		
		Overheating/Setpoint overheating Suction gas temp  Valve opening  Low pressure (relative) Evaporation temp
<b>Status A06</b>		
Working hours Comp.1	000000 h	Operating time
<b>Status A11</b>		
Modbus online: Drive application: Drive motor: Expansion valve:	Yes Yes Yes	Status of communication – control application – motor control – expansion valve control
Auto setup:	On	Auto setup for communication, result.
Start auto setup:	Off	Auto setup for communication.

## 5.6 Cooling Status – Cooling unit, size (code TEC) 16-21

### With control equipment (code MX).

Status information is read on the Climatix display.

Information	Value/example	Explanation
Cooling unit status	Unit ON	Normal status for cooling mode if the compressor is running depends on the cooling load.
	OFFbyALR	Switched off caused by alarm.
	OFFbyDIN	Switched off due to interlock. Climatix interlocks cooling operation.
	OFFbyKey	Switched off due to Carel's ON/OFF menu.
	High cond. temp.	The compressor's speed is limited due to high pressure.
Cooling	50%	Cooling load sent from Climatix to Carel.
Frequency inverter output	60%	
Compr. no		Compressor number, 1 x compressor (C1)
Compr. Sum alarm		
Alarm management		
*****		
Compressor_C1	Off/On	Compressor operating mode.
Suction gas temp_C1	17°C	Measured suction gas temp.
Evaporating temp_C1	10°C	Calculated evaporation temp based on low pressure.
Overheating_C1	7 K	Measured overheating.
Expansion valve_1	65%	Expansion valve position.

### Without control equipment (code UC, MK, US)

Status information is read on the Carel display (Main menu/Status - I/O).

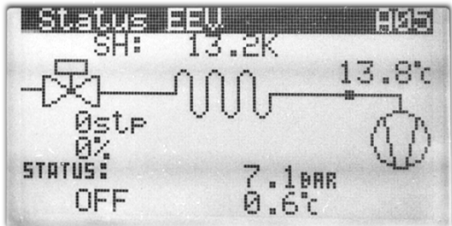
Information	Value/example	Explanation
<b>Status A01</b>		
B1 = Cool.demand:	50%	Cooling load from ventilation control
B2 = Heat demand	0%	Heating requirement
Remove start delay:	NO / YES	Opportunity to quick start the compressor if Yes is set.
<b>Status A03</b>		
ID1= Comp.1 amarm	O	Alarm IN for high pressure switch and frequency inverter
B6 = Remote on/off	O	Interlocking of ventilation control
<b>Status A04</b>		
EVD 1 - DI 1:	O	IN expansion control EVD
EVD 1 - DI 2:	O	IN expansion control EVD
<b>Status A05</b>		
NO1 = Compressor 1	O	OUT for compressor 1
NO2 = Global alarm	C	Alarm OUT for ventilation control
NO3 = 4way valve	C	Not used
<b>Status A06</b>		
Y2= Comp.inverter	0%	OUT signal 0-10V frequency inverter
J8= Modbus activity	NO	Shows whether Modbus is connected
<b>Status A06b</b>		
		Overheating Suction gas temperature  Valve opening Low pressure Evaporating temperature
<b>Status A10</b>		
Working hour		Operating time
Compressor 1	50 h	
<b>Status A11</b>		
cCO address	1	Shows connected EVD on terminal J5

## 5.7 Cooling Status - reversible heat pump (code TTC)

### With control equipment (code MX).

Status information is read on the Climatix display.

Information	Value/example	Explanation
Cooling unit status	UnitOn	Normal status for cooling mode if the compressor is running depends on the cooling load.
	OFFbyALR	Switched off caused by alarm.
	OFFbyDIN	Switched off due to interlock. Climatix interlocks cooling operation.
	OFFbyKey	Switched off due to Carel's ON/OFF menu.
	HighcondTmp	Compressor speed lowered due to the high pressure is high.
	FrostProtOpr	Compressor speed lowered to protect the evaporator from freezing. This is not a fault, but a result of extract air flow and extract air temperature.
Status HP	Alarms	The heat pump is in alarm mode.
	OffbyKey	Switched off due to Carel's ON/OFF menu.
	Temp ctrl.off	The unit is shut off.
	Cooling mode	The heat pump is in cooling mode.
	Low outdoor temp	The heat pump is blocked as the outdoor temperature is too low.
	Low air flow	The heat pump is blocked as the air flow is too low.
	Low return air temp	The heat pump is blocked as the return air temperature is too low.
	HP Tmp dead	The heat pump does not start due to a small temperature deviation.
	Switch off delay	The heat pump is prevented from switching off due to a short time since start.
	Switch on delay	The heat pump is prevented from starting due to a short time since stop.
	Heating mode	The heat pump is in heating mode.
	No need	No need to run the compressor in the heat pump.
	Heating	0%
Cooling	50%	Cooling load sent from Climatix to Carel.



Information	Value/example	Explanation
Freq. inv. output	x.x%	Shows how much of the full capacity is used by the compressor.
Compr. no	Comp1	No. of compressors
Compr. Sum alarm	Normal	Display of sum alarm.
Danfoss invert. Sa alarm		Sum alarm from the frequency inverter for the compressor.
Alarms	>	Alarm information in the submenu.
*****		
Compressor C1	On/Off	Compressor operating mode.
Suction gas temp C1	17 °C	Measured suction gas temp.
Evaporation temp C1	10 °C	Calculated evaporation temp based on low pressure.
Low pressure C1	10 bar	Relative pressure from low pressure sensor.
Overheating C1	7 K	Measured overheating.
High pressure C1	25 bar	Relative pressure from high pressure sensor.
Expansion valve_1	80%	Expansion valve position
Condensation temp C	42.7°C	Calculated condensation temperature based on high pressure.
Hot gas temperature	75°C	Hot gas temperature
Liquid line T	40°C	Liquid line temperature
Supercooling	2.7°C	Supercooling
Compr. frequency	Hz	Compressor frequency
Overheating ref.	K	Setpoint for overheating. Adjusted automatically.









## 6 Maintenance instructions

### 6.1 Service schedule

The service schedule comprises actions and service intervals for functional sections that can be part of the air handling unit. The relevant parts are shown in the order document Technical Data.

Make copies of the service schedule for future use before you fill in servicing data for the first time.

For hygiene inspections according to guideline VDI 6022, see separate [VDI 6022 Checklist for Operation and Maintenance, Hygiene checks](http://ivprodukt.docfactory.com) at [ivprodukt.docfactory.com](http://ivprodukt.docfactory.com).

Service year 20..... - ..... for unit no. ....				Service performed * (date and signature)				
Functional section	Code	Recommended action (insp.)	Page ref.	12 mths	24 mths	36 mths	48 mths	
				date	date	date	date	
	Filter supply air, extract air	ETFL	Check pressure drop Change filter if necessary	33	signature	signature	signature	signature
	Rotary heat exchanger	TXRR	Visual inspection Check press. balance Check diff. pressure Control rotor speed Clean if necessary	36	signature	signature	signature	signature
	Counter-flow exchanger, size 04-12	TXMM	Visual inspection Clean if necessary Check function	41	signature	signature	signature	signature
	Air heater water	ETAB-VV ETAB-TV	Visual inspection Clean if necessary Check function	43	signature	signature	signature	signature
	Air heater electric	ETAB-EV ETKB-EV ETAB-SV	Visual inspection Clean if necessary Check function	45	signature	signature	signature	signature
	Air cooler water/DX	ETKB-VK	Visual inspection Check drainage Clean if necessary Check function	46	signature	signature	signature	signature
	Fan unit	ELFF	Visual inspection Clean if necessary Check the air flow	47	signature	signature	signature	signature
	Damper	ETSP-UM ETSP-TP	Visual inspection Clean if necessary Check tightness	50	signature	signature	signature	signature
	Sound attenuator	ETLD	Visual inspection Clean if necessary	51	signature	signature	signature	signature

*\*More frequent servicing may be required in certain environments. Replace the filter if the pressure drop across the filter exceeds the specified final pressure drop.*



**Cooling unit (code TEC)**

Service year 20..... - ..... for unit no. ....				Service performed * (date and signature)			
Functional section	Code	Recommended action (insp.)	Page ref.	12 mths	24 mths	36 mths	48 mths
				date	date	date	date
 Cooling unit	TEC	Visual inspection Check drainage. Clean if necessary Check function Check for leakage and report if necessary	52	signature	signature	signature	signature

\*More frequent servicing may be required in certain environments.

**Reversible heat pump (code TTC)**

Service year 20..... - ..... for unit no. ....				Service performed * (date and signature)			
Functional section	Code	Recommended action (insp.)	Page ref.	12 mths	24 mths	36 mths	48 mths
				date	date	date	date
 Cooling/heating pump	TTC	Visual inspection Check drainage. Clean if necessary Check function Check for leakage and report if necessary	52	signature	signature	signature	signature

\*More frequent servicing may be required in certain environments.



## 6.2 Filters (code ELEF)

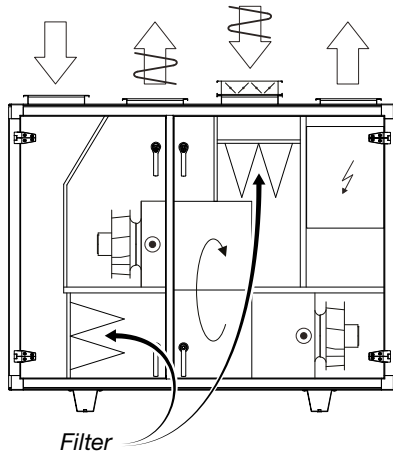

The air filters in an air handling unit are designed to prevent dust and other impurities from entering the building. They should also protect sensitive components inside the unit, e.g. water coils and heat exchangers, from exposure to impurities.

The dust separation efficiency varies considerably between various filter types. The dust collecting efficiency also varies substantially.

It is therefore important to use filters of the same quality and capacity when you change them.

According to guidelines for hygienic design VDI 6022 Part 1: The supply air filter must be class ePM1-50% (F7) or have a greater filtration efficiency.

The filters are designed for one-time use. If they become fouled, the unit will lose capacity. The filters should therefore be changed if the pressure drop across them exceeds the specified final pressure drop.

It is important to stop the unit before changing filters to prevent dust from coming loose and being drawn into the unit. The inside surfaces of the filter sections should therefore also be cleaned when the filters are changed.

### Lifespan and filter control Carbon filter

The function and lifespan of the carbon filters depends on the volume of air that passes through and on the molecular density of odorous substances. This means that the time intervals for filter replacement can vary from unit to unit depending on operation mode and the volume of odorous substances in the air.

Units delivered with control equipment (code MX) are equipped with the filter control function – FLC (Filter Lifetime Control). FLC indicates when it is time to replace the carbon filter. Indication is through an alarm on the Climatix display.

FLC calculates the volume of air passing through the carbon filters and triggers the alarm for filter replacement when the preset value has been reached. The volume of air passing through is measured in mega cubic metres (Mm<sup>3</sup>). The function does not take into account the odour content of the air, which means that the indication should be regarded as a recommendation for checking the filter function. If no odours pass through, there is no need to replace the filter.

Preset FLC values are based on max. air flow over 12 months of full-time operation. If required, the value can be lowered in order to: - change to more frequent filter replacement intervals for max. air flow - retain the filter replacement interval of 12 months for lower air flows.

To change the value, refer separate Climatix control documentation.

## Inspection

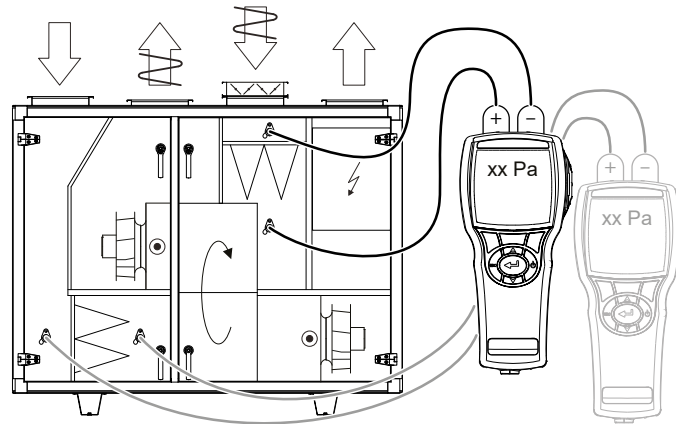

Check the pressure drops across the filters. Pressure drop is measured with a pressure gauge connected to measurement outlets. The measurement outlets are connected to each side of the filter.

If the filter has reached its specified final pressure drop, it should be changed. The final pressure drop is specified on the filter section decal (filled in when the air handling unit is put into operation).

FILTERDATA	
Nominellt luftflöde	<input type="checkbox"/> m <sup>3</sup> /s
Nominal air flow.....	<input type="checkbox"/> m <sup>3</sup> /h
Antal filter	Mått
Number of filters.....	Dimensions.....
.....	.....
.....	.....
Filterklass/Filter Class.....	.....
Begynnelsestryckfall	
Initial Pressure Drop.....	.Pa
Sluttryckfall	
Final Pressure Drop.....	.Pa
Art. Nr: 19121-1101_02SV	

## Filter data

For filter data, refer to [Filter Overview](#) under Documentation at [ivprodukt.docfactory.com](http://ivprodukt.docfactory.com). Actual filters are shown in Technical data (see the page Material specification) and Spare part list under order unique documentation at [docs.ivprodukt.com](http://docs.ivprodukt.com).

## Filter replacement



**WARNING!**  
 Risk of harmful dust when changing filter.  
 Use a dust mask to avoid inhaling dust.

1. Shut down the unit via the service switch in the control equipment, safety switch in the 0 position.

**NB:**

**The safety switch is not designed for starting/stopping the unit. Always use the control equipment to start and shut down the unit.**

2. Wait until the fans have stopped, then open the inspection door.



**WARNING!**  
 Positive pressure inside the unit, risk of personal injury. Allow the pressure to drop before you open the inspection doors.

3. Loosen the eccentric rails.
4. Remove the old filter by pulling it towards you. Discarded filters should be disposed of correctly. The carbon filters are combustible in their entirety.
5. Clean the filter cabinets.
6. Install the new filter, press in the eccentric rails to engage them and close the inspection door.
7. Reset the FLC filter control function via the Climatix display, refer to separate Climatix control documentation. (Only applicable to the Home Concept version of the unit equipped with carbon filter and integrated control equipment (code MX).)
8. Start the unit.

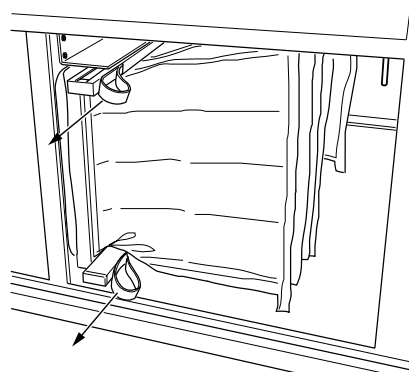

*Example eccentric rails*

## 6.3 Rotary heat exchanger (code TXRR)

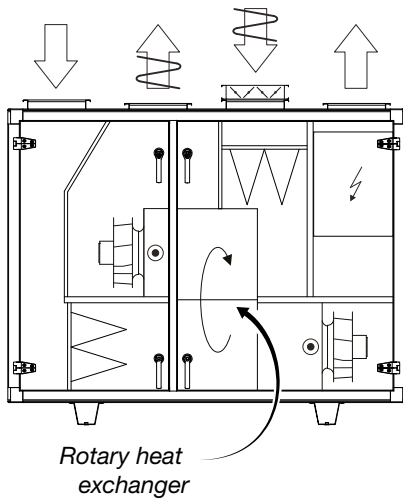

The purpose of the recovery unit is to recover heat from the extract air and transfer this heat to the supply air in order to minimise energy use.

Faults in recovery unit functionality result in reduced heat recovery efficiency and increased energy use and means that the design supply air temperature cannot be obtained when the outdoor temperature is low

A conceivable reason for reduced recovery efficiency may be that the rotor rotates too slowly because the drive belt is slipping. The rotor speed should not be lower than 8 rpm during full energy recovery.

It is not usual for the rotor passages to become fouled with dust, since the rotor is normally self-cleaning. However, this might occur if the dust is of a sticky nature.

A reduction of the extract air flow, e.g. due to fouling of the extract air filter, entails reduced heat recovery efficiency.

Units in the Home Concept design are equipped with a function to control the pressure balance of the rotor to ensure the correct leakage function and purging function. For units supplied with control equipment, the function is connected and activated at the factory. For units without control equipment, this function must be connected to the unit.

### Inspection

1. Shut down the unit via the service switch in the control equipment, safety switch in the 0 position.

---

**NB:**

**The safety switch is not designed for starting/stopping the unit. Always use the control equipment to start and shut down the unit.**

---

2. Wait until the fans have stopped, then open the inspection door.



**WARNING!**

**Positive pressure inside the unit, risk of personal injury. Allow the pressure to drop before you open the inspection doors.**

---

3. Check that the rotor rotates easily. If it is sluggish, you might have to adjust the bristled sealing strip.
4. Check that the rotor's bristled sealing strip seals against the side plates and that it is not worn. The bristled sealing strip is subject to wear and can be adjusted or replaced if the need arises.
5. Check that the drive belt is properly tensioned and does not slip. If it slips, it will have to be shortened. The rotor speed should not be lower than 8 rpm during full energy recovery.

6. Check that the drive belt is intact and clean.
7. Check that the rotor's inlet surfaces are not covered with dust or other impurities. NB: Avoid touching the rotor inlet and outlet surfaces with your hands or tools.
8. Check the pressure balance:

For design Home Concept, the trim damper ETSP-UM/TR regulates the pressure balance automatically against the set value in the controller unit. Check that the measured pressure balance between measurement tappings P2 and P3 corresponds to the set pressure balance setpoint in the controller unit (-10 Pa).

Example:

Measurement outlets for P2: Downstream supply air fan (SF) generates negative pressure in relation to the atmospheric pressure (atm), e.g. -100 Pa

Measurement outlets for P3: Downstream extract air fan (EF) and trim damper generate greater negative pressure than at P2, e.g. -110 Pa.

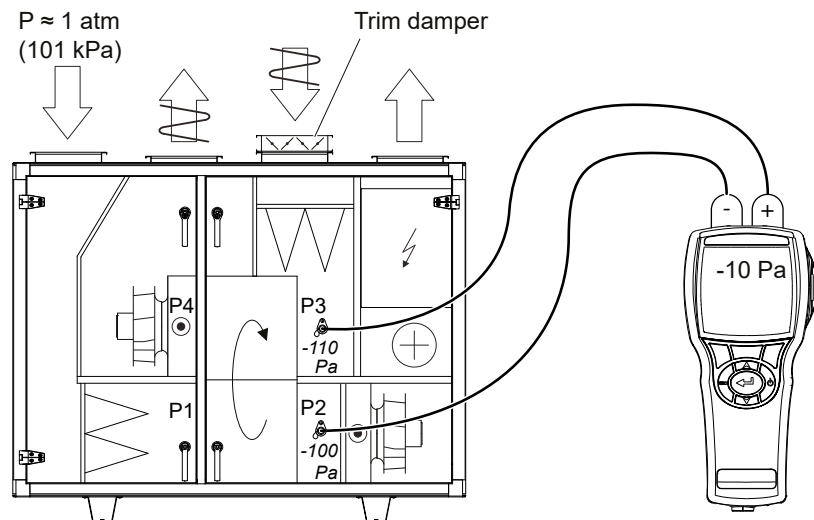

Measurement tapping for pressure balance - units in the Home Concept design.

For units (code TER/TXR), the purging sector function must be ensured by checking that the under pressure P3 is greater than the pressure P2 (min. diff 25 Pa). Otherwise an ETSP-TR trim damper can be used on the extract air side in order to throttle in the correct pressure balance.

Example:

Measurement outlets for P2: Downstream supply air fan (SF) generates negative pressure in relation to the atmospheric pressure (atm), e.g. -100 Pa

Measurement outlets for P3: Downstream extract air fan (EF) and any trim damper generate greater negative pressure than at P2, e.g. -125 Pa.

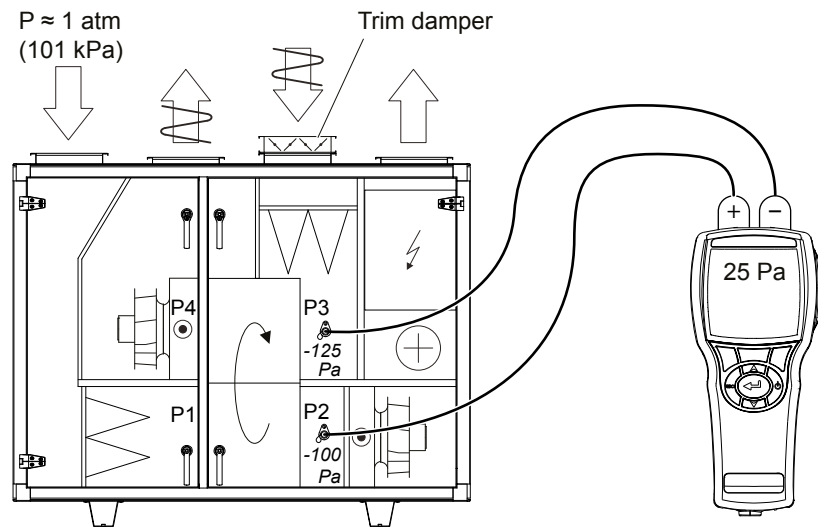

Measurement outlets for pressure balance – unit with control equipment (code MX).

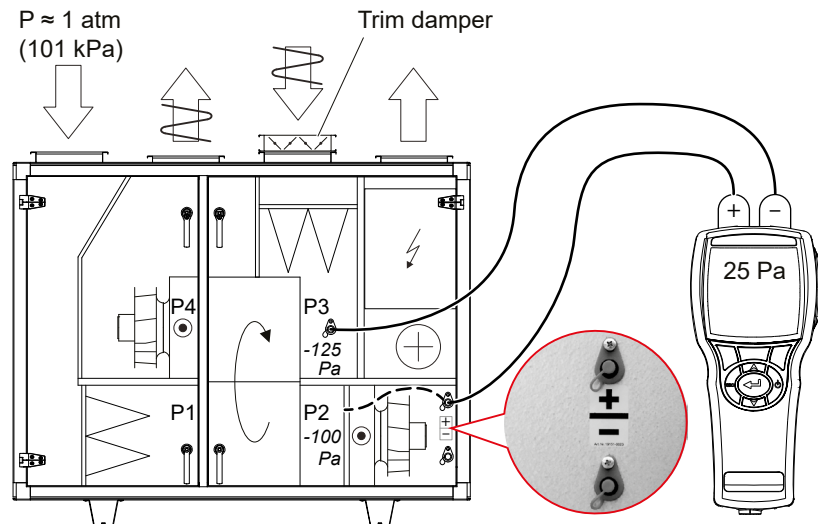

Measurement outlets for pressure balance – unit without control equipment (code UC, MK, US).

9. Check the differential pressure across the rotor. The purging sector is factory-installed, set to the maximum open position. Depending on the unit's pressure difference across the rotor, the purging sector may need adjustment. An incorrect setting may impair the efficiency. Inspection and adjustment should be carried out as follows:

- Measure and write down the differential pressure between the outdoor air (P1) and the extract air (P3).

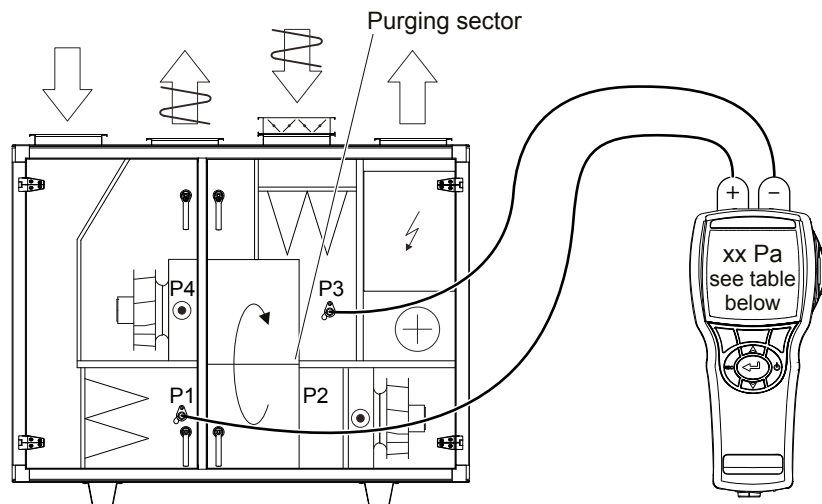

- Read the recommended setting (adjustment hole in the purging sector) from the table below.

	Rotor variant	Adjustment hole in the purging sector		
		3 open*	2 intermediate position	1 closed
Diff. pressure between P1 and P3 (Pa)	NO, NE	< 300	> 300	-
	NP, NX	< 400	> 400	-

\*maximum open purge sector, preset position from the factory

- Adjust the purging sector if the need arises. The illustration shows the purging sector set to the maximum open position.

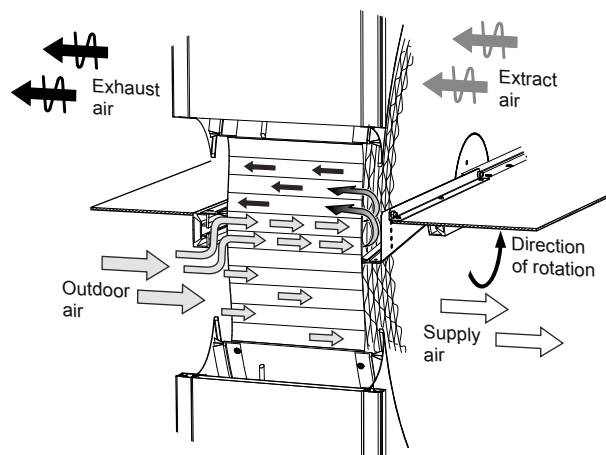

Schematic diagram - sizes and model may vary.



## Cleaning

- Remove dust by carefully vacuum cleaning using a soft brush.
- In the event of stubborn and heavy-duty dirt, the rotor can be sprayed with a mild, alkaline detergent.
- Compressed air at low pressure (max. 6 bar) can be used for blowing the surfaces clean. To avoid damage, the nozzle should not be held any closer to the rotor than 5–10 mm.

A hygroscopic rotor variant can absorb particles which in some cases give off odours. To prevent odours arising, exercise run the hygroscopic rotor using the integrated control function. If an odour persists, we recommend cleaning the rotor with a mild, alkaline detergent.

For cleaning it is recommended that the purge sector is fully open and the rotational speed is 8 rpm. This assists with the sucking through of the detergent. Post-rinsing is not normally required.

## Lubrication

The bearings and drive motor are permanently lubricated and do not require additional lubrication.



## 6.4 Counter-flow exchanger (code TXMM)

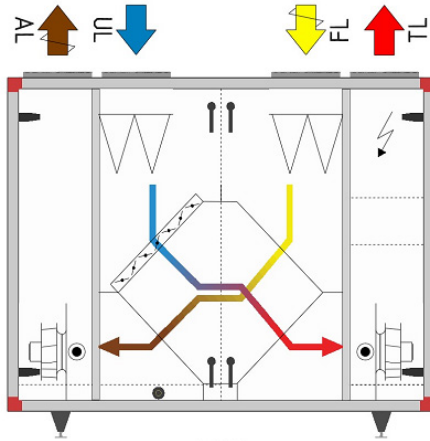

The purpose of the counter-flow exchanger is to recover heat from the extract air and transfer this heat to the supply air in order to minimise energy use.

Faults in counter-flow exchanger functionality reduce recovery efficiency and increase energy consumption. The projected supply air temperature will not be reached when outdoor temperatures are low.

Possible reasons for reduced recovery efficiency could be the fouling of the heat-exchanging surfaces (fins) or that the bypass damper is not closing completely.

A reduction of the extract air flow, e.g. due to fouling of the extract air filter, entails reduced heat recovery efficiency.

### Inspection

1. Shut down the unit via the service switch in the control equipment, safety switch in the 0 position.

**NB:**

**The safety switch is not designed for starting/stopping the unit. Always use the control equipment to start and shut down the unit.**

2. Wait until the fans have stopped, then open the inspection door.



**WARNING!**

**Positive pressure inside the unit, risk of personal injury. Allow the pressure to drop before you open the inspection doors.**

3. Inspect the fins for fouling.
4. Perform a visual inspection of the automatic defrosting dampers and damper motors.
5. Check that the bypass damper is tightly shut when defrosting is not taking place.
6. Check the waste outlet and water trap function. A water trap without a non-return valve should be filled with water.

## Cleaning

The counter-flow exchangers are designed to prevent dirt and deposits from coming into contact with the heat transfer surfaces. Most of the particles in the air will pass through the counter-flow exchanger. The main risk for fouling of the counter-flow exchanger comes from slow-moving substances that condense on the surfaces, and also from fibres from tumble dryers, for instance.

The recommended way to clean the counter-flow exchanger is by flushing with hot water, if necessary adding some mild detergent. The counter-flow exchanger is equipped with a drip tray that is used for collecting the water used for flushing. Inspect the waste outlet and water trap before flushing.

---

**NB:**

**High pressure flushing must not be directed at the fins.**

**Be careful in order to ensure that the fins do not become deformed or break.**

---

At operating temperatures below 0°C, the counter-flow exchanger must be dry before commissioning.

## Functional description, defrost and bypass function (ODS) (code TXMM-XP/NP)

Under certain operating conditions, frost and ice may form on the extract air side of the counter-flow exchanger. In order to optimise heat recovery, there is a built-in defrost function. This is based on the principle that the defrost function is engaged when the pressure drop over the extract air side of the counter-flow exchange exceeds a certain value.

Defrosting takes place through the regulation of dampers on the outdoor air side of the counter-flow exchanger. The dampers have separate damper motors that are controlled by a defrost program. Damper control means that there are a number of different combinations of damper positions, for instance that one of the dampers can be partly open while another is closed and the third damper is fully open.

During full heat recovery and when the unit is switched off, the dampers should be fully open (bypass damper closed). When there is a risk of frost, the dampers can be in different positions.

The defrost and bypass function is preset at the factory and any adjustments must be performed by IV Produkt.

## Functional description, frosting function (BYP) (code TXMM-NP)

Under certain operating conditions, frost and ice may build-up on the extract air side of the heat exchanger. In order to optimise heat recovery, and avoid freezing, there is a built-in frosting function. The principle is based on the frosting function starting when the temperature of the exhaust air side's coldest surface falls below a certain value.

The freezing process is prevented by reducing heat recovery gradually through regulating dampers on the heat exchanger's exhaust air side. The heat recovery damper closes and the bypass damper opens. In this way, the exhaust air temperature is increased and freezing is avoided.

During full heat recovery and when the unit is switched off, the dampers should be fully open (bypass damper closed).

The frosting and bypass functions are preset at the factory and any adjustments may only be performed by IV Produkt.

## 6.5 Air heater water (code ETAB-VV) and Thermoguard (ETAB-TV)

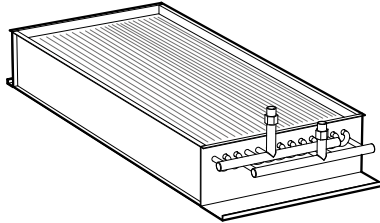

*Air heater water*

The heating coil consists of a number of copper tubes with aluminium fins pressed on them. The coil will have impaired capacity if dust forms a coating on the coil surfaces.

Not only does this impair the heat transfer capacity of the coil, it also increases the pressure drop on the air side. Even if the ventilation system is fitted with high quality filters, as time passes dust deposits will form on the front edges of the coil fins (at the inlet side). To utilise its full capacity, the coil must be well vented. The pipework should be vented by opening the bleeder screws in pipe connections and/or an air vessel.

### Inspection

Check:

1. The coil fins to detect possible mechanical deformity
2. That the water coil is not leaking.

### Cleaning

If the fins on the batteries are dirty, clean them by vacuuming from the inlet side, or carefully blow them clean with compressed air from the outlet side. In the event of stubborn dirt, use a mild, alkaline detergent.

### Bleeding

Bleed the heating coil and the pipework if needed. Bleeder screws are on top of the coil or on the tube connections.

### Function

Check that the coil is radiating heat. This can be done by temporarily increasing the temperature setting (setpoint).



## Additional maintenance for ThermoGuard

1. The ThermoGuard coil must be fitted with a safety valve, the function of which should be checked regularly (at least once a year). If you see that the valve is leaking, this is normally due to impurities from the pipe system that have accumulated on the valve seat. In normal cases, it is sufficient to carefully turn the valve knob and in this way “flush” the valve seat clean. If the safety valve continues to leak, you will have to replace it with a new one of the same type and with the same opening pressure.
2. Any shut-off valves on the supply or return lines may not be closed if freezing temperatures are likely.
3. If a ThermoGuard coil has frozen, let it thaw completely before restarting operation. If the heat recovery unit is installed upstream of the coil, it is often sufficient to run heat recovery to thaw the coil. If this does not work, some other external heating source will have to be used for thawing the water coil.

---

### **NB!**

**To ensure correct ThermoGuard coil function, the entire coil must be allowed to thaw before returning it to full operation. Make sure that water is circulating in the entire coil when you start it up.**

---

## 6.6 Air Heater electric (Code ETAB-EV, ETKB-EV, ETAB-SV)

- ETAB-EV for unit assembly
- ETAB-SV for unit assembly reversible heat pump
- ETKB-EV for duct mounting

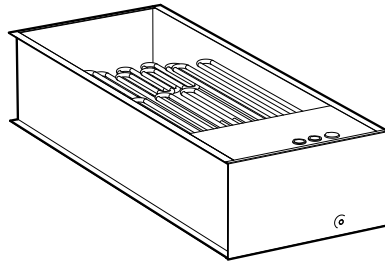

*Air heater electric (ETAB-EV, ETAB-SV)*

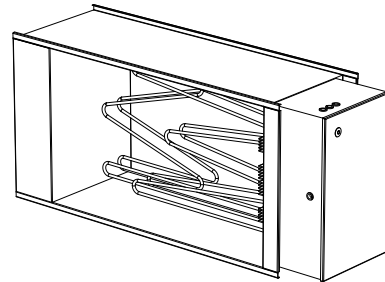

*Air heater electric size 04-12 (ETKB-EV)*

The heating coil consists of “unsheathed” electric heating rods. A substantial accumulation of dust or other impurities on the heating rods will cause them to overheat. This could shorten their service life. This might also entail an odour of burnt dust and, in the worse case, the risk of fire. Overheated electric heating rods may become deformed or loosen from their suspension fasteners and heat the air unevenly.

### Inspection

Check that the electric heating rods are correctly positioned and that they are not deformed in any way.

### Cleaning

Vacuum and/or wipe all surfaces with a cloth.

### Function

1. Simulate reduced required output by temporarily lowering the temperature setting (setpoint), so that all the electric output steps (contactors) switch out.
2. Then sharply increase the setpoint setting and check that the electric output steps switch in.
3. Restore the temperature setting.
4. Stop the air handling unit (NB: Do not break the circuit with the safety switch). All the electric output steps should switch out (i.e. the contactors in the OFF position). Stopping the unit may be delayed approx. 2–5 minutes to allow the fans to cool the heat energy stored in the air heater.

The electric heater is equipped with dual temperature limiters. The one that resets itself automatically should be set to 70°C.

The overheat protection with manual reset interrupts operation when the heater reaches approx. 120°C and is located on the cover panel on the side of the heater. **Determine the cause of overheating and take corrective action before you reset the protection device.**

Please note that the risk of overheating increases as the air flow through the unit decreases. The air speed should not be lower than 1.5 m/s.

## 6.7 Air cooler water (code ETKB-VK)

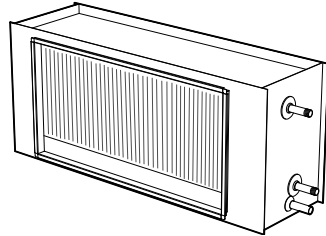

*Air cooler for chilled water*

The cooling coil consists of a number of copper tubes with aluminium fins pressed onto them. The coil will have impaired capacity if dust forms a coating on the coil surfaces.

Not only does this impair the heat transfer capacity of the coil, it also increases the pressure drop on the air side.

Even if the ventilation system is fitted with high quality filters, as time passes dust deposits will form on the front edges of the coil fins (at the inlet side). A drip tray with drain is located under the cooling coil for collecting and removing evaporation water.

### Inspection

Check:

1. The coil fins to detect possible mechanical deformity
2. That the water coil is not leaking
3. That cooling energy is uniformly distributed across the coil surfaces (in operation)
4. The drip tray and drain with water trap (clean if necessary)
5. That the water trap (without non-return valve) is filled with water.

### Cleaning

If the fins on the batteries are dirty, clean them by vacuuming from the inlet side, or carefully blow them clean with compressed air from the outlet side. In the event of stubborn dirt, use a mild, alkaline detergent.

For more information, refer to [Cooling coil, cleaning](#) under Documentation at [ivprodukt.docfactory.com](http://ivprodukt.docfactory.com).

### Bleeding

Bleed the cooling coil and the pipe connections if needed. Bleeder screws are on top of the coil or on the tube connections.

### Function

Check that the coil is emitting cooling energy. This can be done by temporarily lowering the temperature setting (setpoint). Note that cooling is blocked when the outdoor temperature drops below the set value for cooling start.

## 6.8 Fan unit (code ELFF)

The purpose of the fans is to transport air through the system, i.e. the fan must overcome the flow resistance in air terminals, air ducts and the unit.

The fan speed is regulated to provide correct air flow. If the fans generate a lower air flow, this will impair the function of the ventilation system.

- If the supply air flow is too low, the system will be out of balance, causing poor room climate.
- If the extract air flow is too low, the ventilation capacity will be unsatisfactory. Imbalance may also force moist air out into the building structure. One reason why the fans are generating too little air flow may be that impurities have collected on the fan impeller blades.



**WARNING!**

**High voltage, risk of personal injury.**

**Working on/servicing the unit – Shut down the unit via the service switch in the control equipment, then turn the safety switch to the 0 position and lock it.**



**WARNING!**

**Rotating fan impeller, risk of personal injury. Shut down the unit via the service switch in the control equipment, then turn the safety switch to the 0 position and lock it. Wait at least 3 minutes before opening inspection doors.**

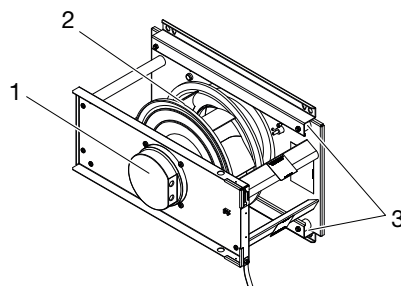

Example fan unit size 04-06

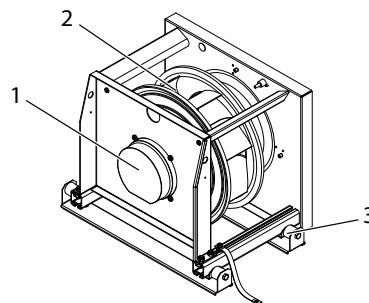

Example fan unit size 09-21

1. EC motor with control unit
2. Fan impeller
3. Anti-vibration mounting

## Inspection

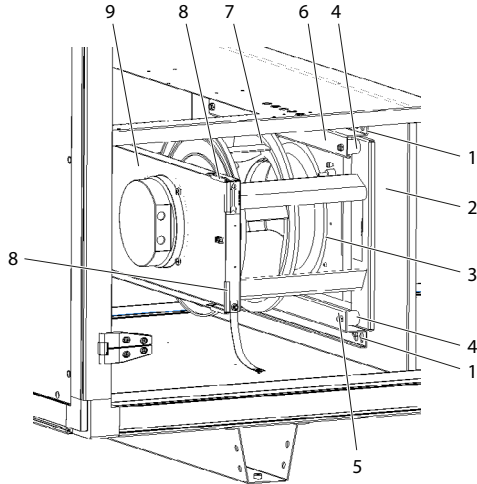

Example fan unit size 04-06

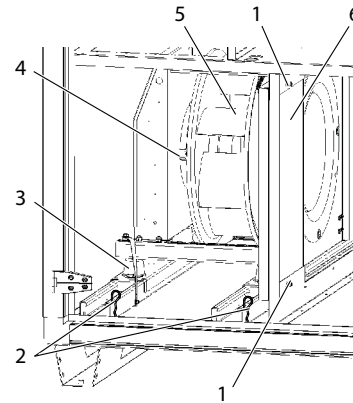

Example fan unit size 09-21

1. Screws suspension
2. Connection plate
3. Inlet cone
4. Anti-vibration mounting
5. Anti-vibration support lower
6. Anti-vibration support upper
7. Fan impeller with motor
8. Edge cover
9. Fan support, upper

1. Screws side cover
2. Pins
3. Anti-vibration mounting
4. Motor
5. Fan impeller
6. Side cover

Remove one end of the fan assembly's earth braid. If necessary, split the motor cable's quick connector.

**For size 04-06:** Remove the screws (position 1) in the connection plate (position 2) and unhook the fan unit from the key holes in the anti-vibration supports (position 5 and 6), both upper and lower.

**For size 09-21:** Remove the screws (position 1) and the pins (position 2). Remove the side cover (pos 6). Pull out the fan units (fan and motor are mounted on slide rails).

2. Check that the fan impeller rotates easily, is in balance and does not vibrate. Also check that the fan impeller is clean from any accumulation of particles. Imbalance may be due to a coating or damage to the fan impeller blades.
3. Listen to the sound from the motor bearings. If the bearings are in good condition, you will hear a slight purring sound. A scraping or pounding sound may mean that the bearings are damaged and service is then required.
4. **For size 04-06:** Check that the fan impeller with motor (position 7) is firmly mounted in the upper fan support (position 9) and that it has not shifted sideways toward the inlet cone (position 3). Also check to make sure that the inlet cone is properly secured. Check that the anti-vibration mountings (position 4) are intact and are firmly fitted.
5. **For size 09-21:** Fan impeller (pos 5) and motor (pos 4) are mounted on a frame equipped with anti-vibration mountings. Check that the anti-vibration mountings (position 3) are intact and are firmly fitted.



6. **For size 04-06:** Make sure the edge cover (pos 8) on the fan support upper (pos 9) sits firmly.
7. Check the mounting bolts, screws as well as the suspension devices and support.
8. Check that the gasket on the connection plate around the connection opening is intact and is firmly fitted.
9. Check that the measurement tubes are securely fitted on each measurement outlet.
10. Remount the fan units.
11. Check the air flows by:
  - reading the flow display on the Climatix display unit for units with control equipment (code MX).
  - measuring  $\Delta p$  in the connections (measurement outlets) for flow measurement +/- for units without control equipment (code UC, MK, US).

Use the unit's air flow label and see which flow corresponds to the measured  $\Delta p$ .

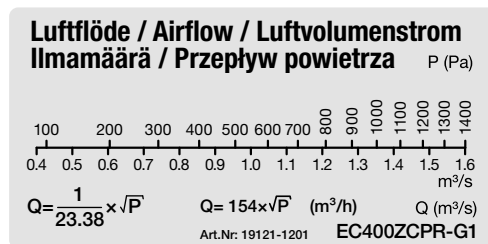

Example of air flow label

## Cleaning

1. Follow item 1 under *Inspection*.
2. Wipe the fan impeller blades to remove any coatings. Use a mild alkaline detergent.
3. The external surfaces of the motor must be kept clean from dust, dirt and oil. Clean with a dry cloth. In the event of stubborn dirt, use a mild alkaline detergent. The motor is likely to overheat inside if thick layers of dirt prevent air from entering the motor to cool the stator structure.
4. Vacuum clean the air handling unit so that particles will not be blown out into the duct system.
5. Clean the other parts in the same way as the fan impellers. Check that the inlet cones are securely mounted.
6. Follow item 10-11 under *Inspection*.

## 6.9 Damper (code ETSP-UM, ETSP-TR, ETRL)

- ETSP-UM - Shut-off damper, rotary heat exchanger and counter-flow exchanger
- ETSP-TR - Commissioning damper, rotary heat exchanger
- ETRL - Return air damper, rotary heat exchanger

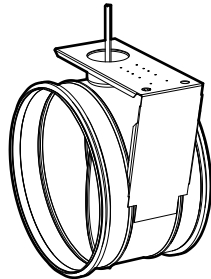

*Damper TER-04 (ETSP-UM, ETSP-TR)*

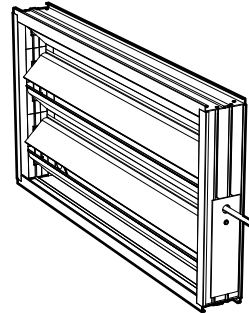

*Damper size 04-21 (ETSP-UM, ETSP-TR, ETRL)*

The purpose of the dampers is to regulate the air flow. Faulty function gives rise to disturbances that may result in serious problems.

- If the outdoor air damper does not: - open completely this reduces the air flow - close completely when the unit stops, the heating coil is likely to freeze - seal properly (leaks) this will result in increased energy use.
- If the trim damper for the rotor purging function is not working or is not correctly adjusted, possible odours in the extract air are likely to be transferred via the rotor to the supply air.

### Inspection

1. Check the function of the damper actuator.
2. Check the dampers for tightness when they are closed. If they are not sealed, adjust the damper actuator to make the dampers tight (does not apply to trim dampers).
3. Check the sealing strips.
4. If the damper is not working, check that there are no screws penetrating the drive mechanism/damper blades to interfere with damper function.

### Cleaning

Clean the damper blades with a cloth. In the event of stubborn dirt, use a mild, alkaline detergent.

## 6.10 Sound attenuator (code ETLD)

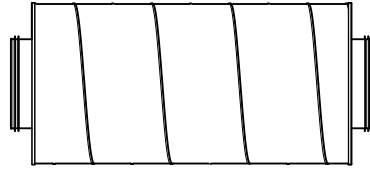

*Sound attenuator TER-04*

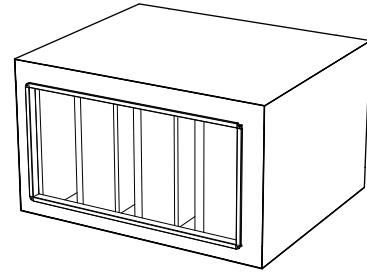

*Sound attenuator size 04-21*

The function of the sound attenuator is to reduce the sound level in the system.

### Inspection

Check that the baffle elements are intact and have clean surfaces. Take action if necessary.

### Cleaning

Vacuum and/or wipe all surfaces with a damp cloth. In the event of stubborn dirt, use a mild, alkaline detergent.



## 6.11 Cooling unit (code TEC) and reversible heat pump (code TTC)

### General

The operation parameters for the unit must not be changed unless a check is first made to ascertain that the changes will be within the unit's operating range.

### Leakage inspection and registration

For information on the operator's responsibility with regards to leakage inspection and registration, see "2.6 Handling of refrigerant" page 8.

### Visual check

Check:

1. fins on the supply air coil/extract air coil for mechanical damage
2. The drip tray and drain with water trap (clean if necessary)
3. that the water trap is filled with water.

### Cleaning

If the fins on the batteries are dirty, clean them by vacuuming from the inlet side, or carefully blow them clean with compressed air from the outlet side. In the event of stubborn dirt, use a mild, alkaline detergent.

For more information, refer to [Cooling coil, cleaning](#) under Documentation at [ivprodukt.docfactory.com](http://ivprodukt.docfactory.com).

### Function

Check that the cooling unit operates as it should by temporarily lowering the temperature setting (setpoint). Note that cooling is blocked during weak air flow or when the outdoor temperature drops below the set value for cooling start.

## 7 Alarm management and troubleshooting

For units with control equipment (code MX), alarm information can be read on the Climatix display.

For units without control equipment (code UC, MK, US), alarm information can be read on the Carel display.

Press the alarm symbol to view alarms.

### 7.1 Cooling unit (code TEC) - size 04 and 16-21

#### Troubleshooting in the event of an alarm

Inspection	Possible cause	Corrective action
Is Carel "High pressure switch (16)" displayed?	YES ⇒ No or too low air flow across the condenser	Check the air flow across the condenser. Reset the pressure switch manually.
	Defective high pressure switch	Check/replace
NO ↓		
Is Carel alarm "LOP" displayed?	YES ⇒ Insufficient refrigerant volume	Look for leakage, seal the leak and top up with refrigerant
	No or too low air flow across evaporator	Check/adjust the flow
	Defective expansion valve or low pressure control	Check/replace
NO ↓		
Is Carel alarm with figures (1)-(15), (17)-(29) displayed?	YES ⇒ Phase failure/voltage failure	Check incoming voltage (phase and neutral). Reset the frequency inverter by switching off the voltage for 1 minute or more. Check that the compressor is running without dissonance.
	Overload/defective stepless compressor	Reset the frequency inverter by switching off the voltage for 1 minute or more. Check that the compressor is running without dissonance.
NO ↓		
Contact support		



## Troubleshooting via symptoms

Symptom	Possible cause	Corrective action
Low cooling power – too high temperature in the cooled object/medium	The power supply has been interrupted	Check the control/safety switches and fuses
	No or too low air flow across evaporator.	Check that nothing is blocking the air-flow.
	The thermostat/control equipment is incorrectly set/defective.	Adjust the settings or replace the equipment
Compressor is not operating	Compressor is not operating	See symptom “Compressor is not operating”
	The power supply has been interrupted	Check the control/safety switches and fuses
	Compressor has opened a safety circuit	Check and reset, if needed
	The control unit is switched off	Start the control unit
Frost on the evaporator	Compressor defect	Check/replace
	The expansion valve is incorrectly preset/defective	Check/replace
	Insufficient refrigerant volume	Look for leakage, seal the leak and top up with refrigerant
	Low supply air flow	Adjust the flow

## Alarm reset

In the event of an alarm initiated by the frequency inverter or the safety circuit, the compressor stops and the sum alarm relay is energised. The alarm is displayed in the control unit menus “Operating information, compressors” and “Status: Alarm”.

In the event of an alarm the fault must be rectified, after which the control unit’s “Alarm reset” button must be pressed for at least 2 seconds. If the safety circuit alarm trips repeatedly, an authorised refrigeration service company must be engaged.

## 7.2 Cooling unit (code TEC) - size 06-12

### Troubleshooting via symptoms

Symptom	Possible cause	Corrective action
The high pressure switch has tripped	No or too low air flow across the condenser	Check the air flow across the condenser. The high pressure switch may have tripped due to a momentary lack of air flow caused by e.g. a closed damper, clogged filter or incorrectly set time control program. Reset the pressure switch manually.
	Defective high pressure switch	Check/replace.
LOC alarm	Insufficient refrigerant volume	Look for leakage, seal the leak and top up with refrigerant.
	No or too low air flow across the evaporator	Check/adjust the flow.
	Defective expansion valve or low pressure control	Check/replace.
The LED is off or flashing green on the frequency inverter (see also information below)	Phase failure/voltage failure	Check the 1-phase supply, measure the incoming voltage. Check the high pressure switch by pressing the button. Reset the frequency inverter by switching off the voltage for 1 minute or more. Check that the compressor is running without dissonance.
	Overload/defective stepless compressor	Reset the frequency inverter by switching off the voltage for 1 minute or more. Check that the compressor is running without dissonance.

### Green light emitting diode (LED) on the inverter

There is a green LED on the inverter's circuit board to indicate status:

- Off – No power supply or faulty power supply. If the LED is off in spite of correct power supply, there could be an internal fault in the inverter.
- Lit – Normal mode, power supply is OK.
- Flashing – The inverter is indicating a problem. Read off the alarm according to "Alarm information for inverter and compressor" page 56 and rectify.

## Alarm information for inverter and compressor

Alarm Climatix (code MX)	Alarm Carel (code UC, MK, US)	Explanation and corrective action
Peripherals	AL P02 Compressor Drive: PERIPHERALS_ERROR	Communication error with the electronic expansion valve. Compressor runs at limited speed.
Outside operating range	AL C01 Compressor Drive: OUT_OF_ENVELOPE	The compressor has worked outside its normal operating range for a long time and stopped. Automatic restart occurs after 60 seconds. After 10 repeated restart attempts, the error must be remedied and the alarm reset.
Overcurrent	AL H01 Compressor Drive: OVER_CURRENT	A too high current has been registered and the inverter stopped. The alarm may be caused by e.g. missing phase (power supply), earth fault, short circuit, compressor fault or internal fault in the inverter. The alarm needs to be reset after repeated start attempts.
High DC voltage	AL H02 Compressor Drive: DCLINK_VOLTAGE_HIGH	A too high voltage has been registered. The alarm may be caused by e.g. a power outage. After 10 repeated alarms, the error must be remedied and the alarm reset.
High inverter temp	AL H03 Compressor Drive: DRIVE_TEMPERATURE_HIGH	A too high temperature in the inverter has been registered (>115°C) and the inverter stopped. The alarm may be caused by e.g. a defective cooling fan, blocked air flow or abnormally high ambient temperature. The alarm needs to be reset.
Low supply voltage	AL H04 Compressor Drive: SUPPLY_VOLTAGE_LOW	A too low supply voltage has been registered (<180 V). Check the voltage level. When the voltage reaches normal level the inverter restarts. <b>The alarm may be the result of a tripped high pressure switch (the inverter loses all power). Reset by pressing the button on the pressure switch.</b>
High hot gas temp	AL D01 Compressor Drive: DISCHARGE_TEMP_HIGH	A too high refrigerant temperature has been registered. The inverter attempts to restart once normal temperature has been registered. After 10 restart attempts, the error must be remedied and the alarm reset.
Hot gas temp error	AL D03 Compressor Drive: DISCHARGE_TEMP_INVALID	Hot gas temperature signal is faulty. There is probably a fault with the wiring or sensor. The inverter is stopped and restarts when the fault is fixed.
MB communication error	AL D04 Compressor Drive: MODBUS_COM_TIMEOUT	The inverter has lost Modbus communication with Climatix control equipment and stopped. Check the high pressure switch by pressing the button. When communication is restored, the inverter is automatically started after 2 minutes.



MOC safety	AL D06 Compressor Drive: MOC_SAFETY	Motor Orientated Control has detected an error. The inverter is stopped. Errors must be remedied and alarms reset. <b>The alarm may be the result of a tripped high pressure switch (the inverter loses all power). Reset by pressing the button on the pressure switch.</b>
Low DC voltage	AL D07 Compressor Drive: DCLINK_VOLTAGE_LOW	The DC voltage in the inverter is too low. The inverter is stopped. When the voltage reaches the correct level the inverter restarts.
Low pressure error	AL D09 Compressor Drive: SUCTION_PRESS_INVALID	Faulty pressure signal for low pressure (suction side). There is probably a fault with the wiring or sensor. The inverter is stopped and restarts when the fault is fixed.
High pressure error	AL D10 Compressor Drive: CONDENSEPRESS_INVALID	Faulty pressure signal for high pressure. There is probably a fault with the wiring or sensor. The inverter is stopped and restarts when the fault is fixed.
High pressure low	AL D12 Compressor Drive: CONDENSER_PRESS_LOW	The pressure at the condenser is too low after starting. After 10 repeated alarms, the error must be remedied and the alarm reset.
Too many starts	AL D15 Compressor Drive: RESTART_TOO_FREQUENTLY	The compressor has been restarted too many times in a 10-minute period and the inverter stopped. The alarm needs to be reset. Check that the air flow is correct. Set the start delay for the compressor to 3 minutes after the compressor is turned off. For UC/MK/US: Check that the regulator that starts/stops cooling mode is not too fast so that the cooling mode hovers between ON and OFF. A maximum of six starts are permitted in 10 minutes; an alarm will be activated otherwise.
Internal inverter error	AL D16 Compressor Drive: INTERNAL_ERROR	An internal communication error has been registered and the inverter stopped. It is likely that the inverter cannot be restarted if this error occurs.
Cooling unit alarm: High pressure switch	AL C02 Compressor 1: Alarm	Alarm from tripped high pressure switch. <b>Reset by pressing the button on the pressure switch.</b>
Outdoor temp error	AL P01 B03 Ambient temp. probe fault or disconnected	The inverter does not receive a value for the ambient temperature and cannot regulate the compressor heat.
-	AL G01 Clock Board fault or not connected	-
-	AL G02 Extended memory Fault	-
Com.Modbus alarm Danfoss: Alarm	AL D18 Modbus communica- tion: Compressor drive AOC	<b>The alarm may be the result of a tripped high- pressure switch (the inverter loses all power). Reset by pressing the button on the pressure switch.</b>
	AL D18 Modbus communica- tion: Compressor drive MOC	
	AL D18 Modbus communica- tion: Compressor drive EEV	

## High pressure switch alarm

If the high pressure switch has tripped, “Cooling unit alarm: Alarm” is displayed. Since the inverter loses all power when the high pressure switch is tripped, a communication error alarm is also displayed, “Com.Modbus alarm Danfoss: Alarm”.

## Alarm reset

- Manually reset alarms caused by a tripped high pressure switch by pressing the red button on the pressure switch.
- Reset alarms from the inverter or the compressor by turning off the power to the unit (inverter) for at least 1 minute.

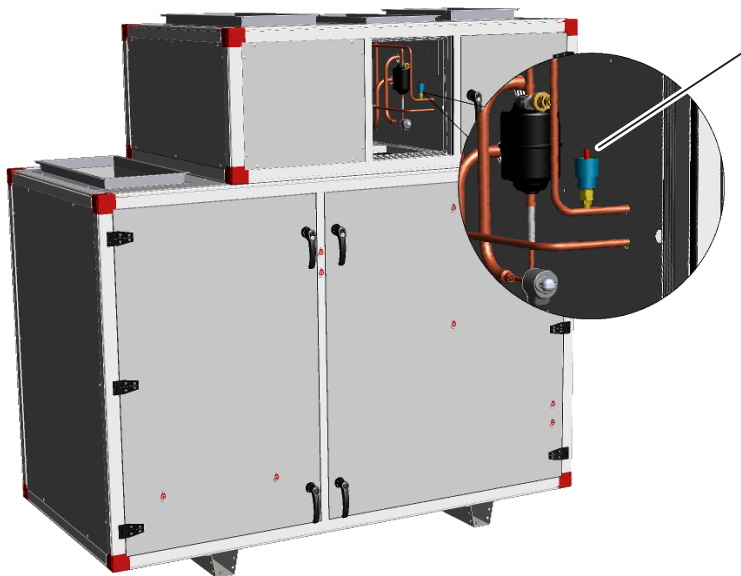

Reset button for  
pressure switch

## 7.3 Reversible heat pump (code TTC)

### Alarm troubleshooting

Inspection	Possible cause	Corrective action
Has the high pressure switch tripped?	YES ⇒ No or too low air flow across the condenser	Check the air flow across the condenser. Rest the pressure switch manually.
	Defective high pressure switch	Check/replace
NO ↓		
Is the alarm “118 Compr 1, Low evaporation pressure” or “176 Compr 2, LowEvap-Pressure” displayed?	YES ⇒ Insufficient refrigerant volume	Look for leakage, seal the leak and top up with refrigerant
	No or too low air flow across evaporator	Check/adjust the flow
	Defective expansion valve	Check/replace
NO ↓		
Is the LED flashing red on the frequency inverter?	YES ⇒ Phase failure/voltage failure	Check the 3-phase supply, measure the incoming voltage. Reset the frequency inverter by switching off the voltage for 1 minute or more. Check that the compressor is running without dissonance.
	Overload/defective stepless compressor	Reset the frequency inverter by switching off the voltage for 1 minute or more. Check that the compressor is running without dissonance.
NO ↓		
Is the alarm “189 Phase Rotation order” displayed?	YES ⇒ Incorrect phase sequence for supply voltage on compressor 2	Shut off voltage and switch two of the incoming phases
NO ↓		
Is the alarm “94 Drive offline” displayed?	YES ⇒ ThermoCooler HP does not have supply voltage 3×400V	Connect supply voltage

## Alarm information for inverter and compressor

Alarm Climatix	Explanation and corrective action
Sum alarm	Sum alarm, check alarm in Carel, see table below.
Alarm C1 R. pressure switch	High pressure switch tripped or alarm for frequency inverter.
Alarm C1 EEV motor fault	Fault on electrical connection to expansion valve.
Alarm C1 low pressure sensor	Power cut or short circuit to low pressure sensor. Check connections on the Carel unit, wiring and sensors.
Alarm C1 suction gas sensor	Power cut or short circuit to suction gas sensor. Check connections on the Carel unit, wiring and sensors.
Alarm C1 high pressure sensor	Power cut or short circuit to high pressure sensor. Check connections on the Carel unit, wiring and sensors.
Alarm C1 low overheating	Compressor stoppage caused by low overheating.
Alarm C1 LOP	Compressor stoppage caused by low evaporation temperature.
Alarm C1 MOP	Compressor stoppage caused by high evaporation temperature.
Alarm C1 communication EVD	Fault on communication to EVD (expansion valve control).
Alarm C1 low suction gas temp	Low suction gas temperature.

Alarm Carel	Explanation and corrective action
76 Drive MainsPhaseLoss	Check that all three phases are connected to the frequency inverter.
81 Drive U_phaseLoss	
82 Drive V_phaseLoss	
83 Drive W_phaseLoss	
94 Drive offline	No communication with the frequency inverter. Check that the frequency inverter is energised with 3-phase 400V.
118 Compr 1, Low evaporation pressure	Circuit 1, low evaporation temp/pressure. Check leakage in cooling circuit.
121 Compr 1, High pressure switch	Circuit 1, high pressure switch tripped. Check air flow and fire damper.
180 Compr 1, High pressure switch	Circuit 1, high pressure switch tripped. Check air flow and fire damper.

## Troubleshooting via symptoms

Symptom	Possible cause	Corrective action
Low cooling power - too high temperature in the cooled object	The power supply has been interrupted	Check the control/safety switches and fuses.
	Separate supply not connected	Connect supply
	None or too low air flow across evaporator	Check that nothing inhibits the air flow
	The control equipment is incorrectly pre-set/defective	Adjust the settings or replace the equipment
Compressor is not operating	The power supply has been interrupted.	Check the control/safety switches and fuses
	Incorrect phase sequence (compressor 2)	Switch two of the incoming phases
	Compressor has opened a safety circuit	Check and reset, if needed
	Defective compressor	Check/replace
Frost on the evaporator (heating application)	Expansion valve is defective	Check/replace
	Insufficient refrigerant volume	Look for leakage, seal the leak and top up with refrigerant
	Low return air flow	Adjust the flow

## Alarm reset

In the event of an alarm initiated by the frequency inverter or the safety circuit, the compressor stops and the sum alarm relay is energised. The alarm is displayed in the control unit menus "Operating information, compressors" and "Status: Alarm".

In the event of an alarm, take corrective action to correct the fault, and then press the "Alarm reset" button on the control unit for at least 3 seconds. If the safety circuit alarm trips repeatedly, an authorised refrigeration service company must be contacted.



*Air handling with focus on LCC*

## **You are welcome to contact us**

---

Switchboard:	+46 (0)47 075 88 00	
Control support:	+46 (0)47 075 89 00	<a href="mailto:styr@ivprodukt.se">styr@ivprodukt.se</a>
Service:	+46 (0)47 075 89 99	<a href="mailto:service@ivprodukt.se">service@ivprodukt.se</a>
Spare parts:	+46 (0)47 075 88 00	<a href="mailto:spareparts@ivprodukt.com">spareparts@ivprodukt.com</a>
<b>Visit us at:</b>	<b><a href="http://www.ivprodukt.com">www.ivprodukt.com</a></b>	
Documentation for your unit:	<a href="http://docs.ivprodukt.com">docs.ivprodukt.com</a>	
Technical documentation:	<a href="mailto:docs@ivprodukt.se">docs@ivprodukt.se</a>	