

## Electric air heater fitting (code MIE-EL)



MIE-EL coil fitting is designed for electric air heater (code ELEE). The fitting consists of assembly rails, inspection doors and a housing front section for integration into the standard module (code EMM).

The electric air heater (code ELEE) is an electric heater in a high-temperature design.

- The heating rods consist of stainless pipe elements SS 2337 / AISI 321.
- The heater has double over-temperature guards that cut the power if there is a risk of overheating. One of the guards is reset manually.
- Protection IP43 in accordance with SS-EN 60529.
- Also available with integrated control equipment (HS) for power control.
- There are up to five output variants per size available as standard. Other outputs may, however, be supplied to specification.

## Technical data, size 740

### Configuration

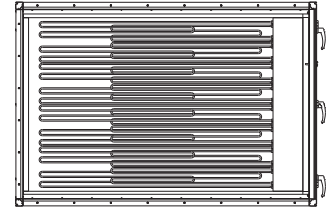
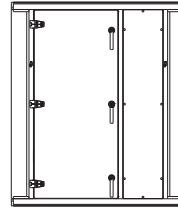

### Electrical data

Output variant	Min. air flow (m <sup>3</sup> /s)	Total output (kW)	Rated current (A) 3×400V~50Hz
01	3.3	48	69.3
02	3.3	86	124.1
03	3.3	135	196.0
04*	3.3	162	233.8

\* not available in HS version

### Power stage HT (without control system)

Output variant	Output steps (kW)			
	1	2	3	4
01	3.2	6.4	12.8	25.6
02	5.7	11.5	22.9	2 × 22.9
03	9.0	18.0	36.0	2 × 36.0
04	11.0	22.0	43.0	2 × 43.0

### Insert damping (dB)

Octave band intermediate frequency (Hz)	63	125	250	500	1000	2000	4000	8000
ELEE	1	1	1	1	1	1	1	1

## Wiring instructions

### Electric heater without control system (HT)

Ø 1 Ø 2	Overheat protection with automatic reset.
Ø 3 Ø 4	Overheat protection with manual reset.
Ø 5 Ø 6 Ø 7	Connecting the first step: 0,2-3,5 kW 2-phase 400 V. NB: For output power > 3.5 kW the first step is 3-phase 400 V.
Ø Ø Ø	Connecting the second step: 3.6-43 kW 3-phase 400 V
Ø Ø Ø	Connecting the third step: 3.6-43 kW 3-phase 400 V
Ø Ø Ø	Connecting the fourth step: 3.6-43 kW 3-phase 400 V

Output steps to be connected sequentially, beginning at terminal no 5.

If any output group exceeds 43 kW, it must be divided into two groups of an equal size.

### Electric heater with integrated control (HS)

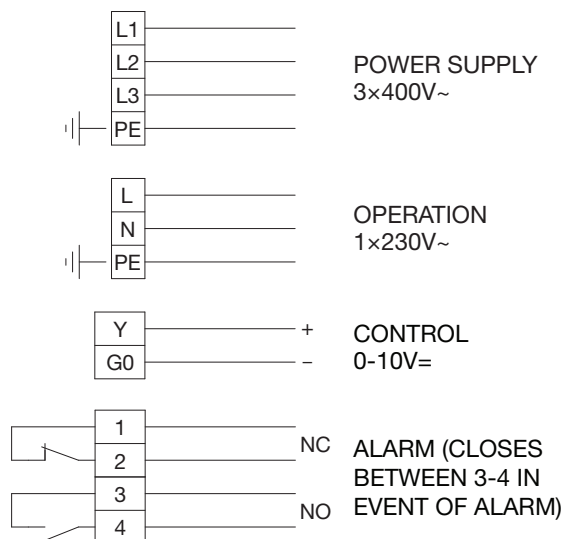

## Operation and Maintenance Instructions

The heating coil consists of “unsheathed” electric heating rods. A substantial accumulation of dust or other impurities on the heating rods will cause them to overheat. This could shorten their service life. This might also entail an odour of burnt dust and in the worse case, the risk of fire.

Overheated electric heating rods may become deformed or loosen from their suspension fasteners and heat the air unevenly.

### Inspection

Check that the electric heating rods are correctly positioned and that they are not deformed in any way.

### Cleaning

Vacuum or wipe surfaces with a moist cloth to remove any dust or impurities.

### Function

1. Simulate reduced required output by temporarily lowering the temperature setting (setpoint), so that all the electric output steps (contactors) switch out.
2. Then sharply increase the setpoint setting and check that the electric output steps switch in.
3. Restore the temperature setting.
4. Stop the air handling unit (NB: Do not break the circuit with the safety switch). All the electric output steps should switch out (i.e. the contactors in the OFF position). Stopping the unit may be delayed approximately 2–5 minutes to allow the fans to cool the heat energy stored in the air heater.

The electric heater is equipped with dual temperature limiters. The one that resets itself automatically should be set to 70 °C.

The overheat protection with manual reset interrupts operation when the heater reaches approximately 120°C and is located on the cover panel on the side of the heater. **Determine the cause of overheating and take corrective action before you reset the protection device.**

Please note that the risk of overheating increases as the air flow through the unit decreases. The air speed should not be lower than 1.5 m/s.