Installation

NEW EcoHeater
English



Table of Contents

| | | |
|------|---|----|
| 1 | Safety precautions | 1 |
| 1.1 | Personal protective equipment | 1 |
| 1.2 | Prevent injury to personal and damage to air handling units | 1 |
| 1.3 | Product signs, information and warning stickers | 2 |
| 1.4 | Safety message | 2 |
| 1.5 | General safety messages | 3 |
| 2 | General | 6 |
| 2.1 | Intended use | 6 |
| 2.2 | Manufacturer | 6 |
| 2.3 | Designations | 6 |
| 2.4 | CE marking and EU Declaration of Conformity | 7 |
| 2.5 | Maintenance | 7 |
| 2.6 | Extended warranty | 7 |
| 2.7 | Spare parts | 7 |
| 2.8 | Dismantling and decommissioning | 7 |
| 2.9 | Installation instructions | 7 |
| 3 | Lift off unit | 8 |
| 3.1 | Lifting of unit with bracket EMMT-08 | 9 |
| 3.2 | Lifting units mounted on base frame | 10 |
| 3.3 | Lifting with forklift | 10 |
| 3.4 | Spreader bar | 11 |
| 4 | Unit placement | 12 |
| 5 | Requisite service areas | 13 |
| 6 | Installation of functional section | 14 |
| 6.1 | Block sections | 14 |
| 7 | Components/accessories for duct installation | 16 |
| 8 | Duct connection, general | 18 |
| 9 | Schematic diagram, recommended connection | 19 |
| 10 | Connection of liquid | 20 |
| 11 | Quick connectors | 22 |
| 12 | Power supply, control and communication | 23 |
| 13 | Wiring instructions and fuse protection | 24 |
| 13.1 | Wiring diagrams | 24 |
| 13.2 | Recommended external fuse and power supply | 24 |
| 13.3 | Wiring instructions | 25 |



1 Safety precautions

Follow all safety precautions in this document and pay attention to all warning signs on the air handling unit.

Failure to comply with the safety precautions may result in injury to persons or damage to air handling units.

1.1 Personal protective equipment

Personal protective equipment must always be used based on the risks present at the workplace. Comply with national and local laws and regulations.

The following personal protective equipment is recommended where the work requires:

- Protective shoes with steel cap
- Hearing protectors
- Safety helmet
- Gloves
- Goggles
- Covering clothing
- Protective overalls
- Mouthguard/protective mask
- Fall protection

1.2 Prevent injury to personal and damage to air handling units

To avoid injury to persons or damage to air handling units, pay attention to the following:





- Read the entire document before working on the unit.
- Comply with national and local laws and regulations for work safety.
- Do not wear loose clothing or jewellery that may get fasten.
- Do not step or climb on the unit.
- Use recommended tools and equipment intended for the job.
- Use recommended personal protective equipment when the work requires it.
- Observe the unit's product signs, information and warning stickers.
- Keep the unit clean and follow the Operation and Maintenance Instructions.
- Make sure that all covers are in place, that inspection covers are closed and that lockable inspection covers are locked before starting the unit and after repairs/service.
- Use appropriate fall protection when working at heights - normally over 2 meters. Even work at lower heights may require protective measures.

1.3 Product signs, information and warning stickers

Keep signs and stickers free from soiling and replace them if they are lost, damaged or illegible. Contact IV Produkt for replacement stickers; specify the item number.

1.4 Safety message

The following warning symbols and signal words are used in this document to inform of risks.

| | |
|--|---|
|  DANGER! | Danger - indicates an imminent dangerous situation which, if not avoided, can result in death or serious injury. |
|  WARNING! | Warning - indicates a potentially dangerous situation which, if not avoided, can lead to serious injury. |
|  CAUTION! | Caution - indicates a less potentially dangerous situation which, if not avoided, can lead to less serious or minor injuries. |
|  NB: | NB: – indicates a potentially hazardous situation which, if not avoided, may result in damage or impaired function of the air handling unit. |

1.5 General safety messages

Comply with the following general safety messages.

Lockable safety switch

| | |
|---|---|
|  | <p>DANGER! Risk of serious injury. Electrical power can cause electric shock, burns and death.</p> <p>Working on/servicing the unit – Shut down the unit via the service switch in the control equipment, then turn the safety switch to the 0 position and lock it.</p> <p>There may be several safety switches serving the different parts of the unit. All safety switches must be switched off before repairs/service.</p> |
|---|---|

| | |
|---|--|
|  | <p>NB: The safety switch is not designed for starting/stopping the unit. Always use the service switch in the control equipment to start and shut down the unit.</p> |
|---|--|

Electrical connections

| | |
|---|---|
|  | <p>DANGER! Risk of serious injury. Electrical power can cause electric shock, burns and death.</p> <p>Working on/servicing the unit – Shut down the unit via the service switch in the control equipment, then turn the safety switch to the 0 position and lock it.</p> <p>There may be several safety switches serving the different parts of the unit. All safety switches must be switched off before repairs/service.</p> |
|---|---|

| | |
|---|---|
|  | <p>WARNING! Risk of personal injury. Rotating fan impellers can cause crushing injuries or lacerations. The unit must not be energised until all ducts have been connected.</p> |
|---|---|

| | |
|---|--|
|  | <p>NB: Wiring of connections and other electrical work may only be carried out by a qualified electrician or by service personnel recommended by IV Produkt.</p> |
|---|--|

Inspection hatches



WARNING!
Risk of personal injury.
Overpressure in unit.
Allow the pressure to drop before you open the inspection doors.



WARNING!
Risk of personal injury.
The doors in front of moving parts shall normally be locked; there are no contact guards.

During repairs/service, the inspection doors are locked with the supplied keys.

Make sure that all hatches are closed and that lockable inspection hatches are secured before starting the unit and after repairs/service.

Heat pump



WARNING!
Risk of personal injury.
Hot surfaces can cause burns.

Working on/servicing the unit – Shut down the unit via the service switch in the control equipment, then turn the safety switch to the 0 position and lock it.

There may be several safety switches serving the different parts of the unit. All safety switches must be switched off before repairs/service.

Wait at least 30 minutes before opening the compressor inspection hatches.

Fan



WARNING!

Risk of personal injury.

Rotating fan impellers can cause crushing injuries or lacerations.

Working on/servicing the unit – Shut down the unit via the service switch in the control equipment, then turn the safety switch to the 0 position and lock it.

There may be several safety switches serving the different parts of the unit. All safety switches must be switched off before repairs/service.

Wait at least 3 minutes before opening inspection hatches.

Filter



WARNING!

Risk of personal injury – harmful dust.

Use a face mask/respiratory protection to avoid inhaling dust.

Directive



WARNING!

The products may not be put into service until the machinery or installation in which they are incorporated complies with the requirements of EU Machinery Directive 2006/42/EC, EMC Directive 2014/30/EU, Low Voltage Directive 2014/35/EU, PED Directive for pressure equipment of Module A2, Cert.nr. 18-1012273-100 and 1253/2014 and 811/2013 Ecodesign Regulation.

2 General

2.1 Intended use

The EcoHeater extract air heat pump is intended for energy recovery from the extract air in apartment buildings.

When installed indoors, the unit must be installed in an area that maintains a temperature between +7 and +30°C, and with a moisture content of <3.5 g/kg in dry air in the winter. The unit can also be equipped for installation in cold attics or outdoors.

Any other use and setup in other environments are prohibited unless specifically permitted by IV Produkt AB.

It is not permitted to use the unit in potentially explosive environments, Ex.

2.2 Manufacturer

The EcoHeater extract air heat pump is manufactured by:



IV Produkt AB
 Sjöuddevägen 7
 S-350 43 VÄXJÖ

2.3 Designations

The EcoHeater extract air heat pump comprises two to three sections, fan section, compressor section and a possible combustion gas bypass.

Each section has a model identification label placed on the front.

The model identification label shows the series number and the requisite designations to identify the section.

| | |
|---|---|
| Ordernr / Order No / Tilaus nr / Nr zam / Auftragsnr. <input type="text"/> |  |
| Modell / Model / Malli / Model / Modell <input type="text"/> | |
| Produktkod / Product code / Tustekoodi / Kod produktu / Produktcode <input type="text"/> | |
| Aggregatbeteckning / Project / Kohde / Agregat / Bezeichnung <input type="text"/> | |
| Tillv.ort / Made in / Valmistettu / Produkcja / Herst. Ort <input type="text"/> | |
| Tillv.m / Manuf.m. / Valmistus. k / Miesiav. pr / Herst. Monat <input type="text"/> |  |

Art.nr. 19121-1001

Typical model identification label

2.4 CE marking and EU Declaration of Conformity

EcoHeater extract air heat pumps are CE marked, which means that upon delivery, they conform to applicable provisions in EU Machinery Directive 2006/42/EC as well as to the EU Directives applicable to other types of air handling units, e.g. the Pressure Equipment Directive.

As certification confirming that the requirements have been met, we provide an EU Declaration of Conformity, which is available under Documentation at ivprodukt.docfactory.com, or under Order Unique Documentation at docs.ivprodukt.com.



Typical CE label for air handling units

2.5 Maintenance

The ongoing maintenance of this unit can be carried out either by the person normally in charge of maintaining the building or through a contract with a well-reputed service company. Service and repair of the refrigerant circuit are carried out by a certified refrigeration technician.

2.6 Extended warranty

In cases in which the equipment delivered is covered by a 5-year warranty, in accordance with ABM 07 with appendix ABM-V 07 or in accordance with NL 17 with appendix VU20, the IV Produkt Service and Warranty Manual is supplied with the product.

In order to claim an extended warranty, a complete, documented and signed IV Produkt Service and Warranty Manual must be presented.

2.7 Spare parts

Spare parts and accessories for this unit can be ordered from IV Produkt's nearest dealership. When ordering, the order number and designation must be given. These are stated on a model identification label, affixed to each functional section.

There is a separate spare parts list for the unit, refer to Order Unique Documentation at docs.ivprodukt.com.

2.8 Dismantling and decommissioning

When an air handling unit is to be dismantled, separate instructions must be followed, see [Dismantling and decommissioning the AHU](#) under Documentation at ivprodukt.docfactory.com.

2.9 Installation instructions

For proper function and for the warranty to be valid, the installation instructions must be followed.

3 Lift off unit

**DANGER!**

Risk of serious injury.

Falling units can cause crushing injuries.

Damaged bracket or bracket without or missing sticker may NOT be used.

**DANGER!**

Risk of serious injury.

Falling units can cause crushing injuries.

Slide stops must always be mounted when lifting.

**DANGER!**

Risk of serious injury.

Falling units can cause crushing injuries.

Lift equipment attached in the lifting brackets must be dimensioned for the applicable load.

**CAUTION!**

Risk of personal injury.

Sharp edges can cause cutting injuries.

The following personal protective equipment is recommended where the work requires.

3.1 Lifting of unit with bracket EMMT-08

- Lifting brackets EMMT-08 (accessories) are placed in the lower four corners of the unit and are slid into the existing horizontal groove in the aluminium section.
- The slide stop is pushed into the vertical groove in the aluminium bar and locked with the wing screw in the lifting bracket.
- The slide stop must be mounted in the lifting bracket before lifting the unit.
- The bracket must be mounted with the lifting lug up, not down or to the side.
- The equipment must be handled with care both during installation and storage.
- If the bracket binds when mounting, do not use it.
- Maximum weight per bracket: 400 kg. Maximum weight, unit with 4 brackets: 1600 kg.
- Visual inspection must be carried out on the bracket before use. There may be no cracks or deformations. Rivets must not be rusty or damaged.
- A spreader bar must be used. See "3.4 Spreader bar" page 11.

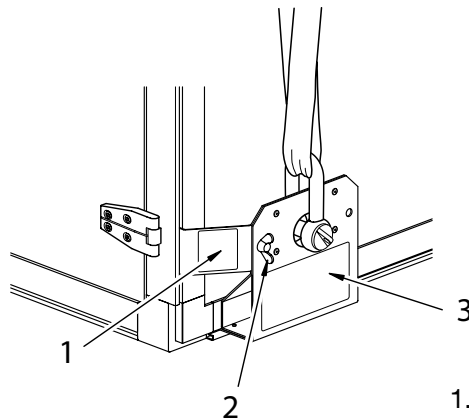

1. Slide stop with sticker
2. Wing screw
3. Lifting bracket with sticker

3.2 Lifting units mounted on base frame

- When the unit is mounted on a base frame, lifting is performed with the help of lifting lugs.
- The lifting lugs are screwed into the grooves in the base frame on the aluminium base frame.
 For frame 100 mm, max. length 6,000 mm, max. weight = 3,000 kg
 For frame 160 mm, max. length 7,000 mm, max. weight = 5,400 kg
- On welded supports, the lifting lugs are welded in the base frame.
 For frame 160 mm, max. length 10,000 mm, max. weight = 10,000 kg
- Lifting straps must not be pulled through the lifting lugs: Shackles shall be used and dimensioned for the applicable load with the required safety factor (6:1).
- A spreader bar must be used. See "3.4 Spreader bar" page 11.

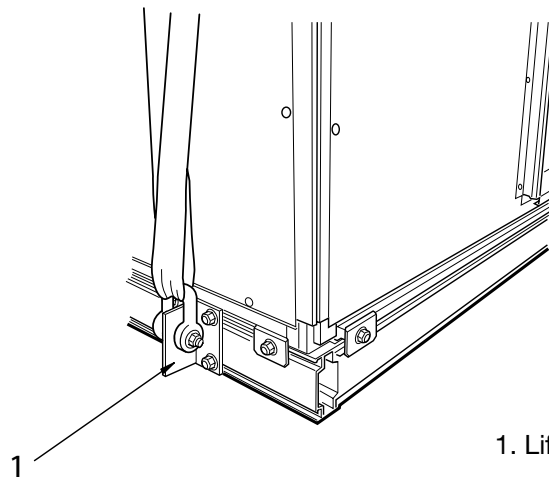

1. Lifting lug for base frame

3.3 Lifting with forklift



NB:
 The length of the lifting forks must be longer or as long as the unit packaging.

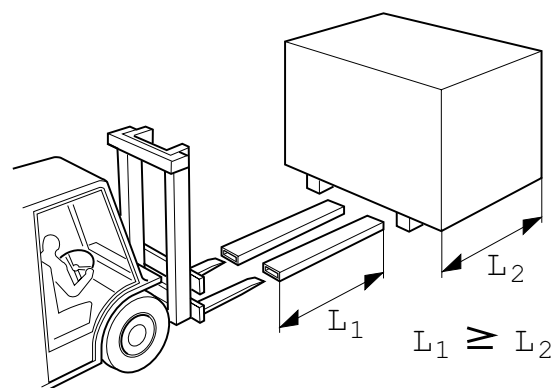

3.4 Spreader bar

| | |
|---|---|
|  | <p>NB: Risk of damage to the unit. A spreader bar must be used. Chains/straps must not rest against the unit when lifting.</p> |
|---|---|

- When lifting using EMMT-08 or when lifting in a base frame, a spreader bar must be used.
- The size of the spreader bar must be approximately 100 to 400 mm wider than the unit.
- Depending on the design of the unit, it is usually enough to use a spreader bar on the short sides of the unit.
- It is important that chains/straps do not come into contact with any part of the unit when lifting.
- Maximum angle at lifting hook, 80°.
- Maximum tilt when lifting is 15°.

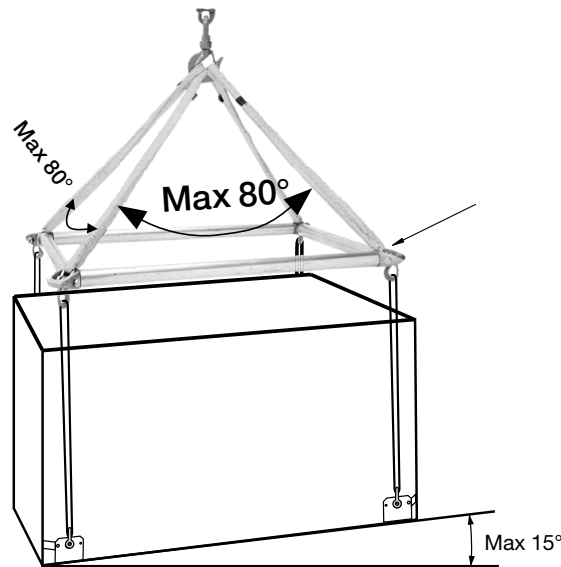

NB: The shackle must be dimensioned for the applicable load with the required safety factor (6:1).

4 Unit placement

The unit is installed on a flat, vibration-dampened, horizontal surface. The example above shows a "floating floor", which provides good vibration dampening. On a floating floor, a waterproof trough with water run-off should be constructed for drainage of condensation water.

- 1 Joists, when installed above noise-sensitive environments, additional measures must be taken.
- 2 Joist insulation
- 3 Flooring panel
- 4 Drainage/water run-off
- 5 Mineral wool 100 mm
- 6 Particleboard 22 mm or equivalent
- 7 Watertight trough with water run-off

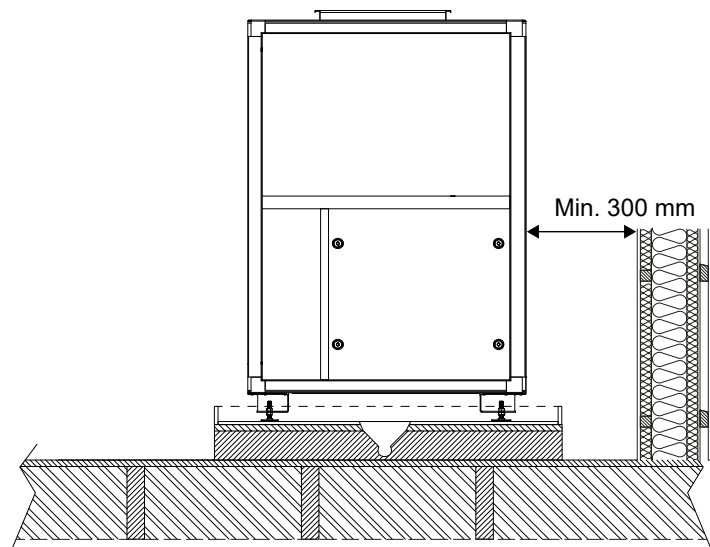
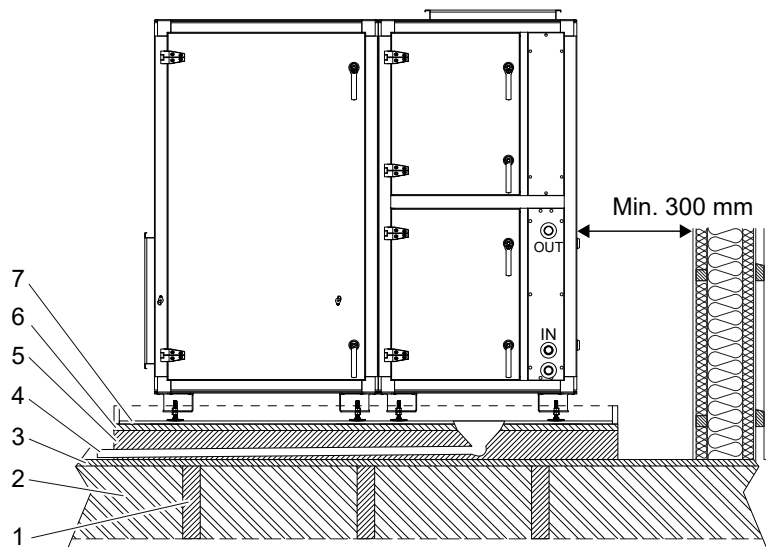

5 Requisite service areas

- The service areas must extend along the entire unit and at least 300 mm to the side of the compressor section and behind the unit.
- Free space in front of unit, service and open space in front of the unit for servicing, should be $1.5 \times \text{depth } D$ (at least 1200 mm).

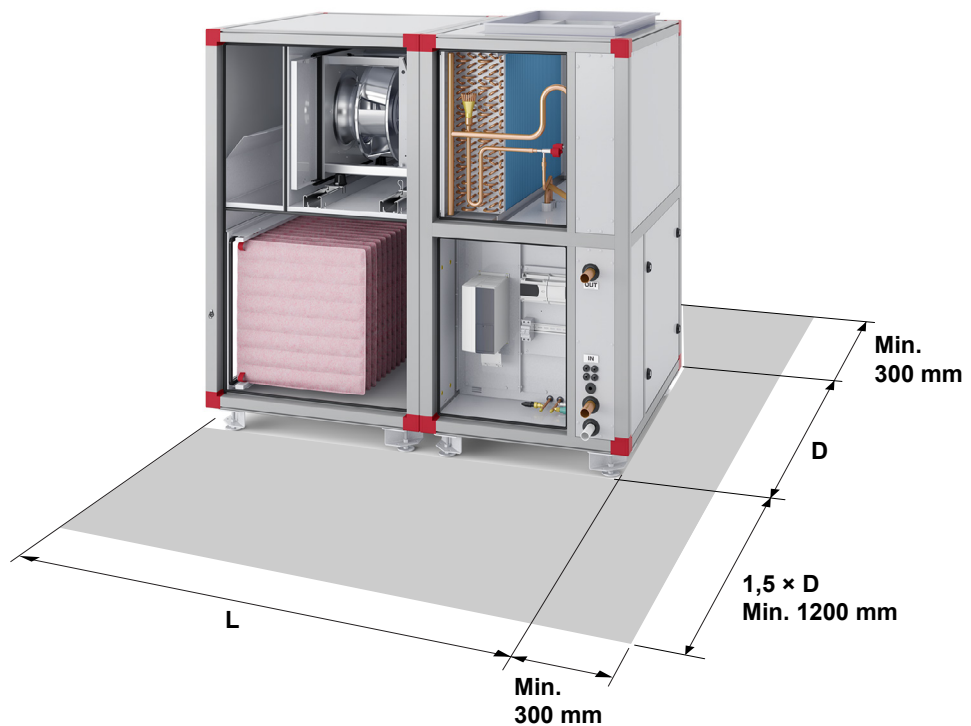

6 Installation of functional section

6.1 Block sections

EcoHeater comes in 4 different delivery versions: blocks, blocks with tripod legs, blocks with base frame (indoor support EMMT-05, and outdoor version with base frame).

For installation drawing, refer to docs.ivprodukt.com (Technical data).

1. Fit the supplied gasket between the parts (1).
NB: The supplied gasket is doubled - separate the gasket before installation.
2. Position the functional sections close together.
3. Fit guide key (2) or bolted joint (3). If you do not want to pull out the fan to access the bolted joints, a guide key can be used. Cross-tighten the bolted joints.

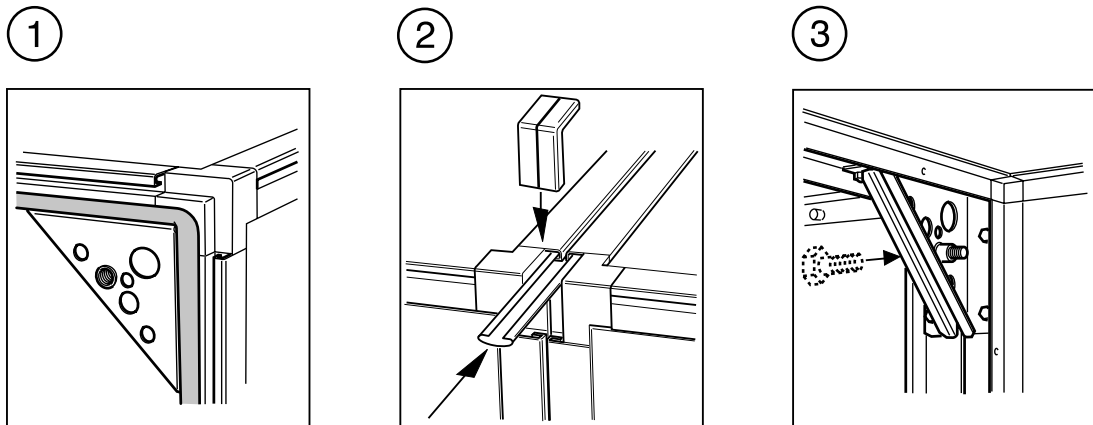

NB: A guide strip is used in the bottom joint between the fan section and the compressor section (solid red line). This is because the lower bolted joints furthest into the unit are inaccessible. For assembly of other joints (dashed red lines), either guide strips or bolted joints can be used.

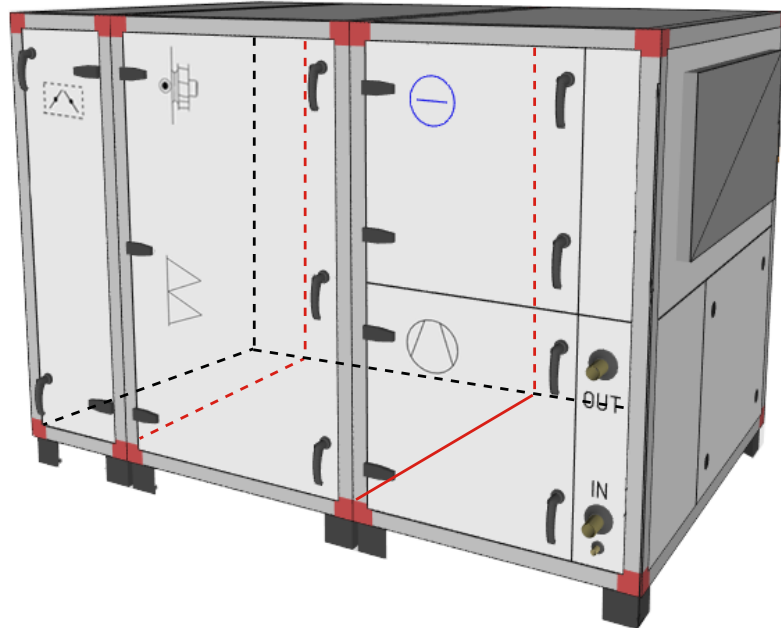

4. Mount the outer corner.
5. Check that doors/inspection hatches can be opened and closed.

7 Components/accessories for duct installation

- Sound attenuator, EMT-02. Rectangular connector for guide system.
- Shut-off damper EMT-0. Damper can be installed for horizontal or vertical air streams. Rectangular connector for guide system.
- Module section with internal damper EHP-B. Opens for bypass via filter in the event of a fire.
- Fan section EHP-F.
- Compressor section EHP-C.
- Sleeves are available as duct accessories.

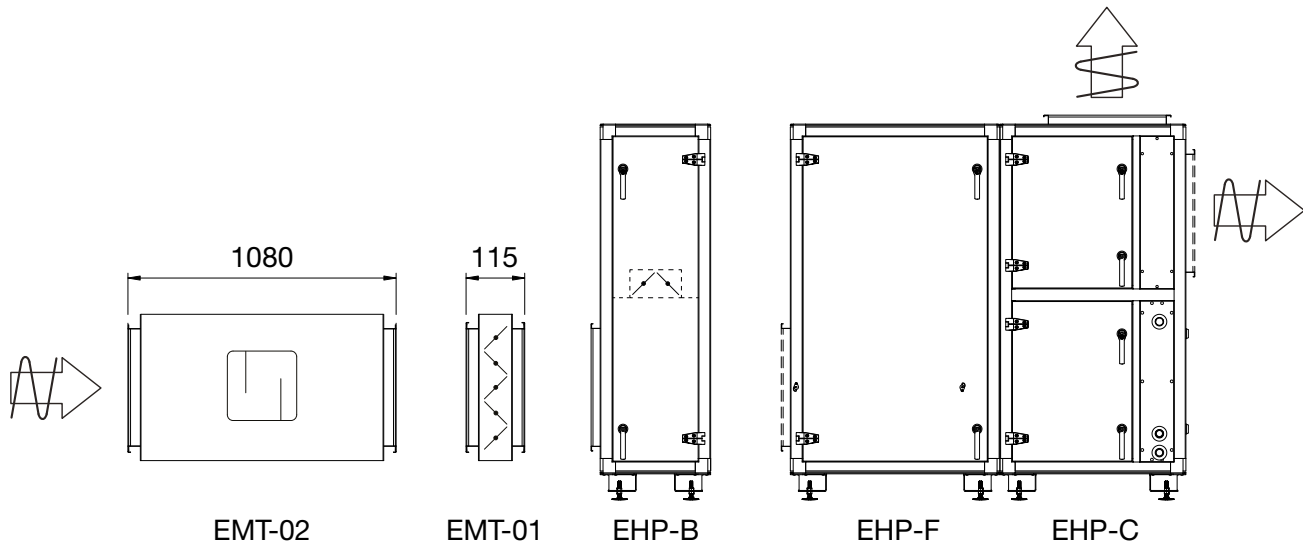

- Vertical spring damper, accessory for vibration dampening.

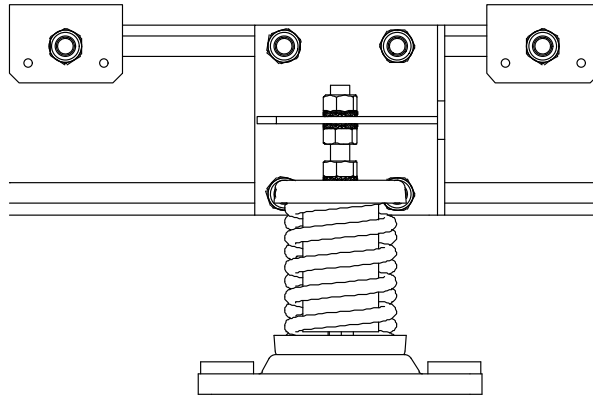

- Sylodyn, accessory for vibration dampening. Before installation, place the sylodyn mat under the plate.

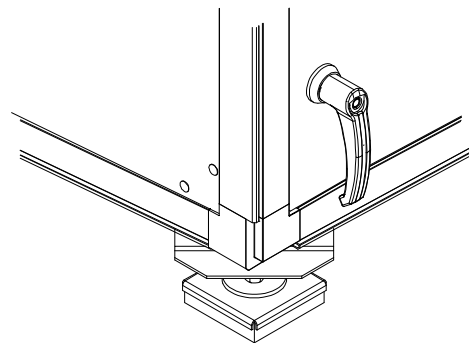
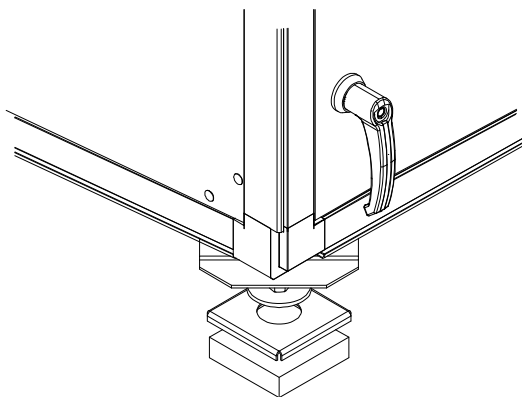

8 Duct connection, general

- The units/modules have a rectangular connector for the guide system. The ducts are connected with a gasket, guide key and external corner. Connection is as shown in Figure A.
- Alternatively, the ducts are connected with bolts at the corner of the frame as shown in Figure B.
- If the ducts are connected with sleeves (which is recommended for dampening vibrations), the duct insulation is installed over the entire connection. Sleeves not supplied by IV Produkt.

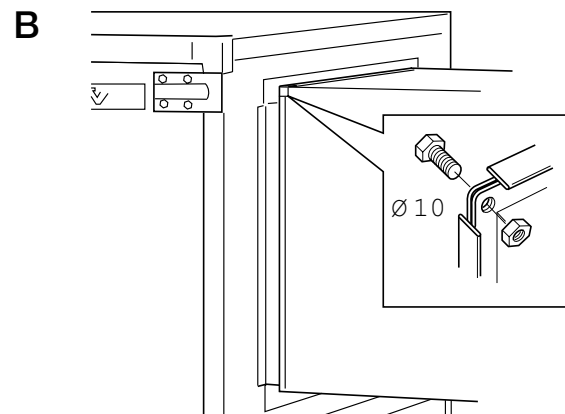
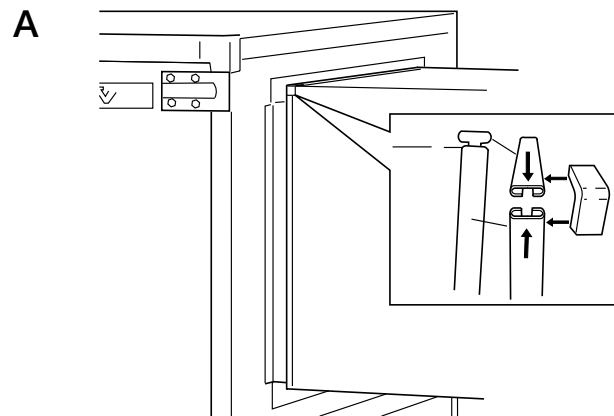

9 Schematic diagram, recommended connection

Keep in mind during the planning stage that the pipe system must be complemented with the necessary pumps, adjusting valves, etc. to gain full function.

- Drain Condensation outlet (frost protected)
- GT3 Temperature sensor outdoor air (to be placed northeast)
- CP1 Circulation pump heat pump

For more information, see Operation and Maintenance, principle drawings and Control Diagram at docs.ivprodukt.com.

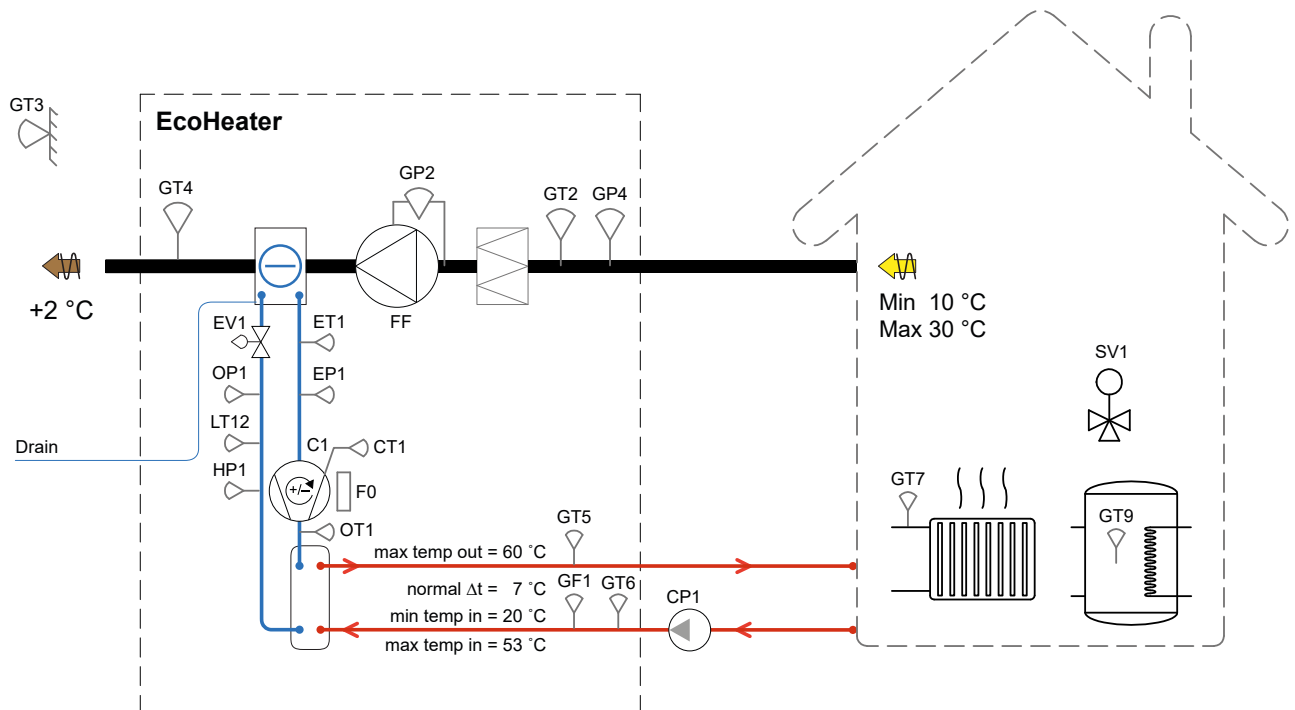

10 Connection of liquid

1. Clamping rings and flexible hoses

The provided clamping ring couplings and flexible hoses are connected to the heat pump (IN/OUT). We recommend that the hoses be fitted using a 180° elbow, minimum bending radius 180 mm. Tighten using an additional spanner so as not to damage the piping system.

2. Liquid connection

The filter for removing particles (POS 2a) is mounted on the inlet connection (IN). If shut-off valves are installed on the connections, also fit a pressure relief valve (on the compressor side). The connections can also be complemented with bleeder valves. The particle filter, shut-off valves, pressure relief valve and bleeder valves are not supplied by IV Produkt.

3. Condensation outlet

The condensation outlet (ABS plastic pipe, Ø32 connection) is mounted so that the condensation water flows into a floor drain or similar device.

Once the connection of the liquid side is complete, the system must be bled at the highest point and the liquid flow adjusted according to the dimensioned flow.

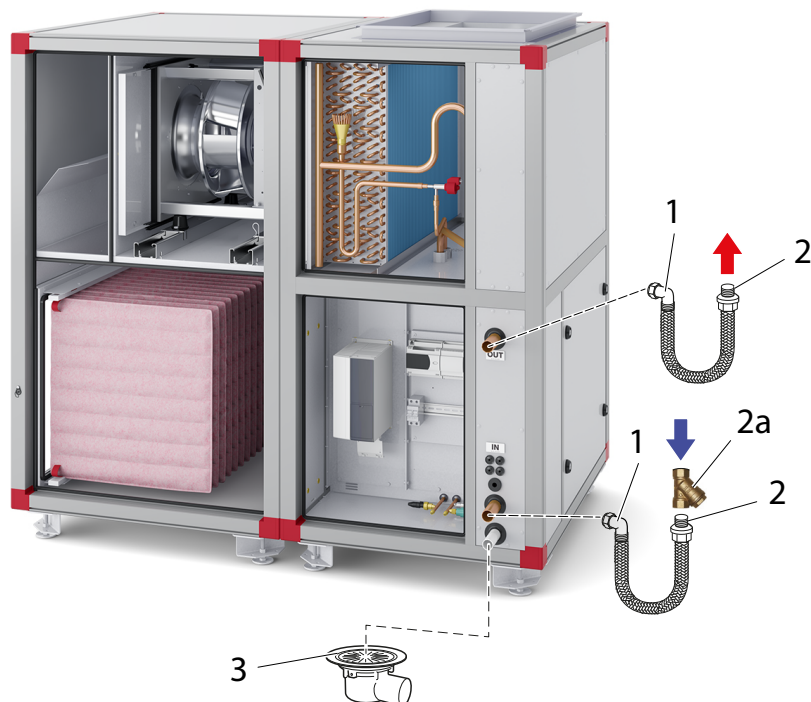
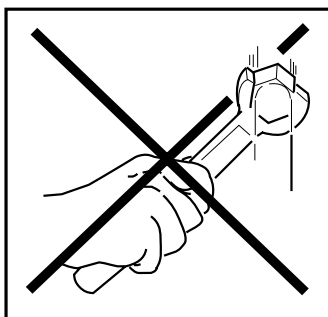
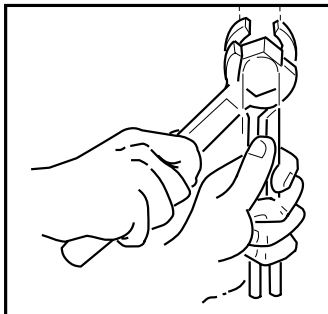

Water traps must not be installed for outdoor units. For indoor units, water traps can be used to avoid any unpleasant odours.

The pipe should be insulated if it is located in a cold area.

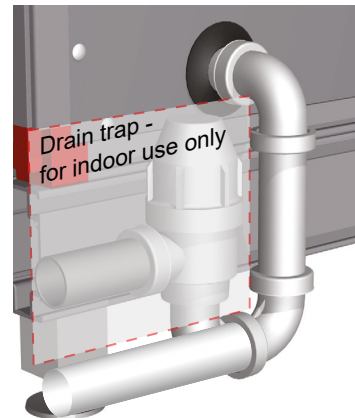

11 Quick connectors

Connect (connect together) the quick connectors between the fan section and the compressor section.

NB: Check that the markings correspond to the connectors/cables before assembly.

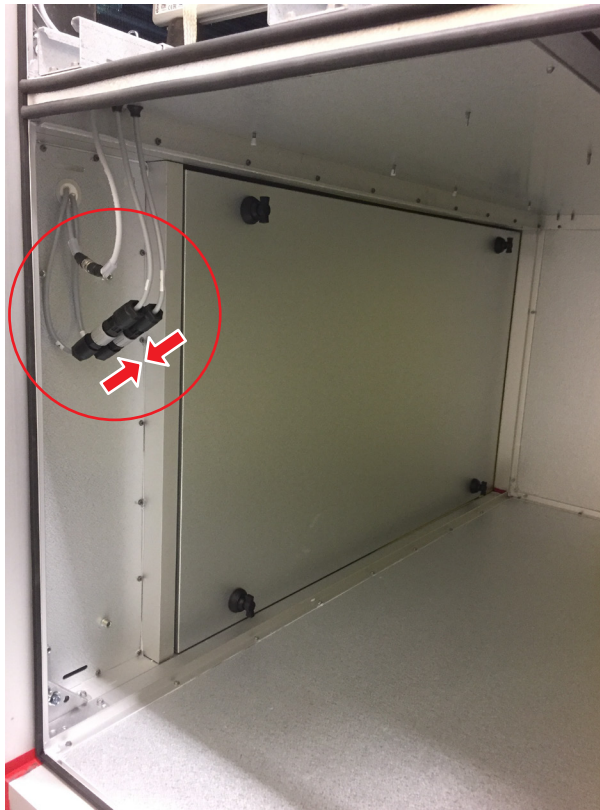

12 Power supply, control and communication



DANGER!
 Risk of serious personal injury and/or damage to air handling unit.
 Read and understand the entire chapter "1.5 General safety messages" before working on, servicing, or inspecting the air handling unit.

1. Connect the power supply to the main switch.
2. Establish communication with sub-central unit (BMS) if applicable. Communications can be via COM* or signal cable.
3. Make sure that the EcoHeater receives a signal from the temperature sensor for outdoor air (via COM* or signal cable).

* For communications (COM) with EcoHeater, see docs.ivprodukt.com (Control Diagram).

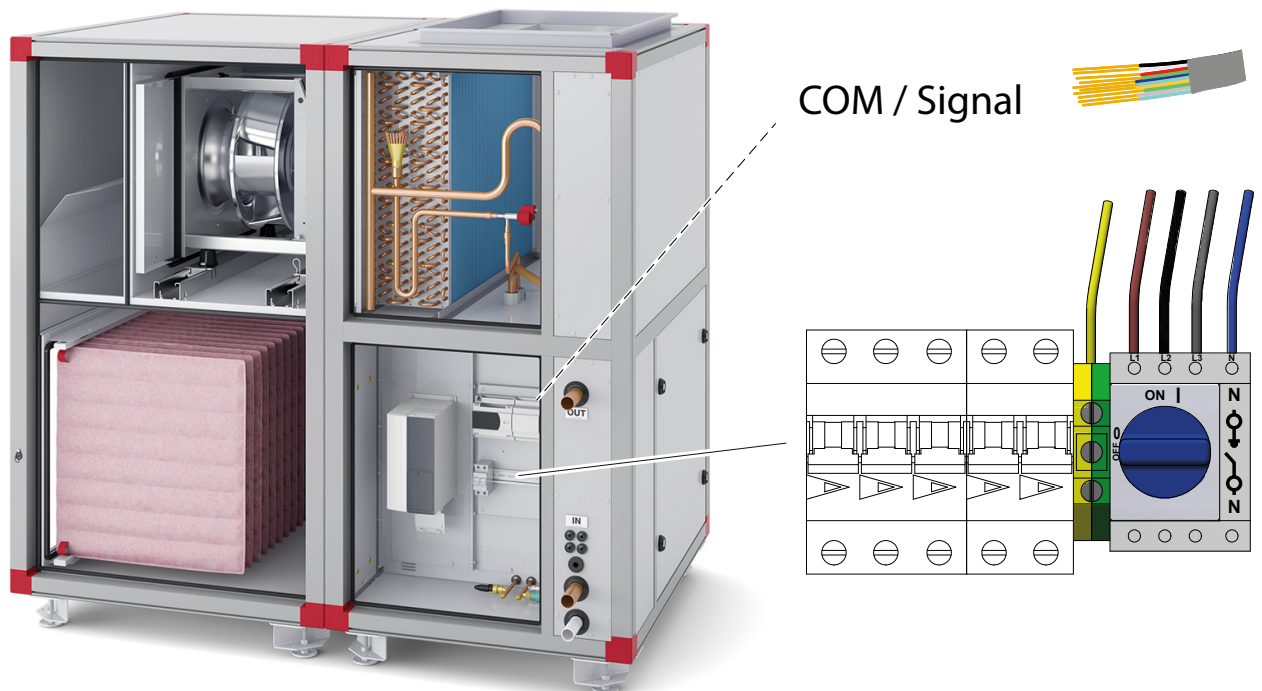



13 Wiring instructions and fuse protection

13.1 Wiring diagrams

For wiring diagrams, see order-unique electrical diagrams enclosed with the delivery of a unit or on docs.ivprodukt.com (Control diagram).

13.2 Recommended external fuse and power supply

The power supply is connected to the switch in the compressor section.

For recommended external fuse and power supply, refer to docs.ivprodukt.com (Technical Data).

13.3 Wiring instructions

Code STA-08 - Temperature control external 0-10 VDC

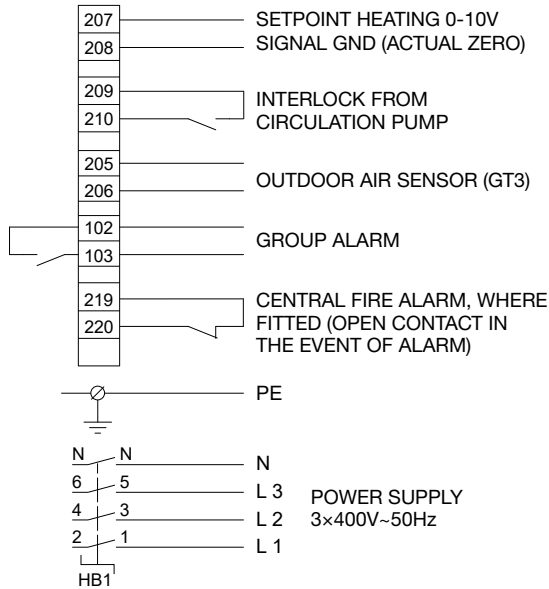

Code STA-09 - Temperature control internal radiator curve

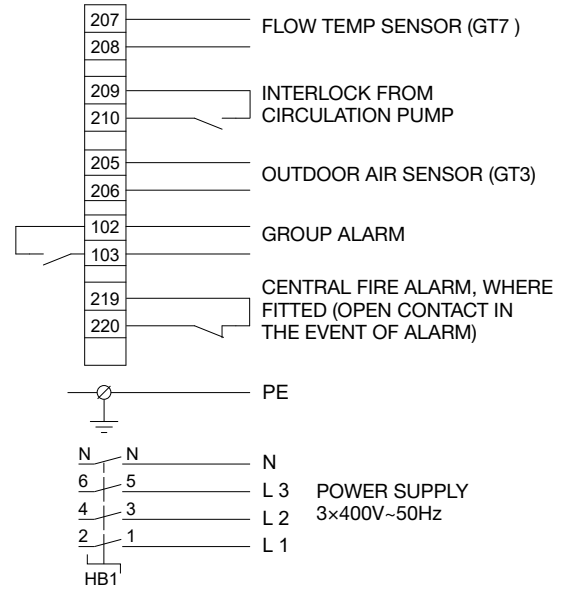

Code STA-08-1 - Temperature control external 0-10 VDC and temperature control of accumulation tanks

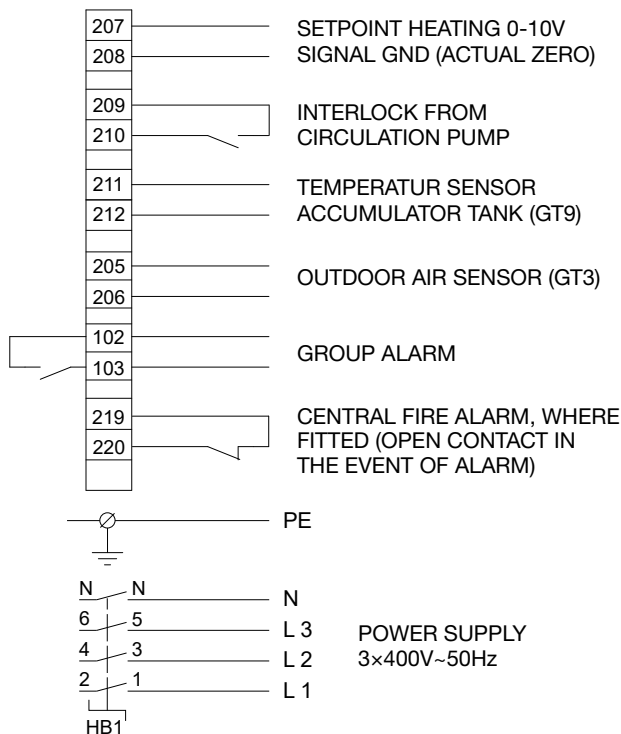

Code STA-09-1 - Temperature control internal radiator curve and temperature control of accumulation tanks

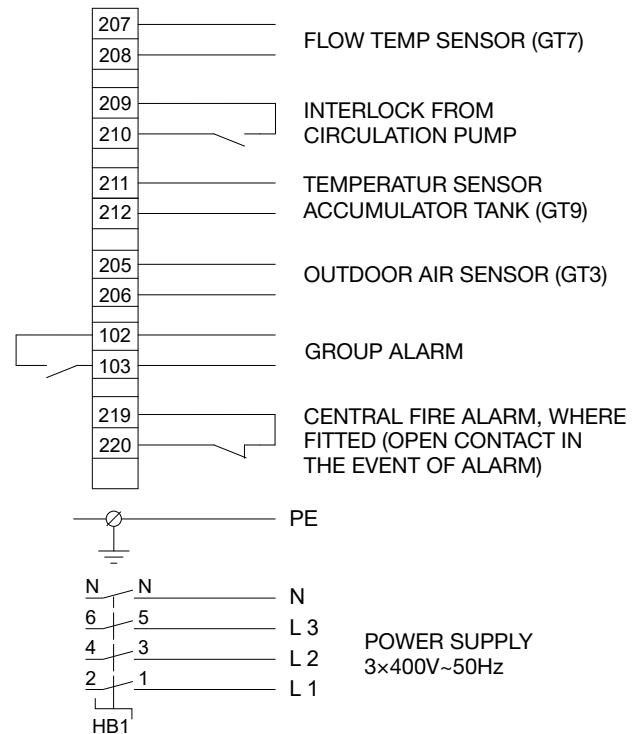



Code STA-10 - Temperature control of accumulation tanks

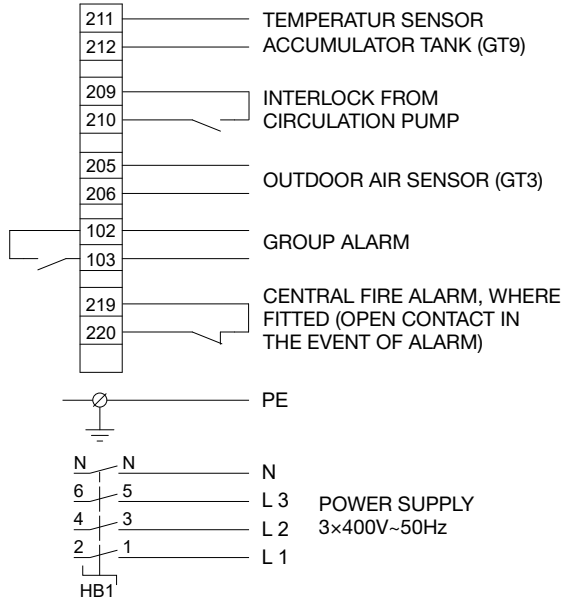



Air handling with focus on LCC

You are welcome to contact us

| | | |
|------------------------------|--|--|
| Switchboard: | +46 (0)47 075 88 00 | |
| Control support: | +46 (0)47 075 89 00 | styr@ivprodukt.se |
| Service: | +46 (0)47 075 89 99 | service@ivprodukt.se |
| Spare parts: | +46 (0)47 075 88 00 | spareparts@ivprodukt.com |
| Visit us at: | www.ivprodukt.com | |
| Documentation for your unit: | docs.ivprodukt.com | |
| Technical documentation: | docs@ivprodukt.se | |