

Examples of useful BACnet addresses for Counter-flow, Plate and Run-around coil heat exchangers

Counter-flow heat exchanger

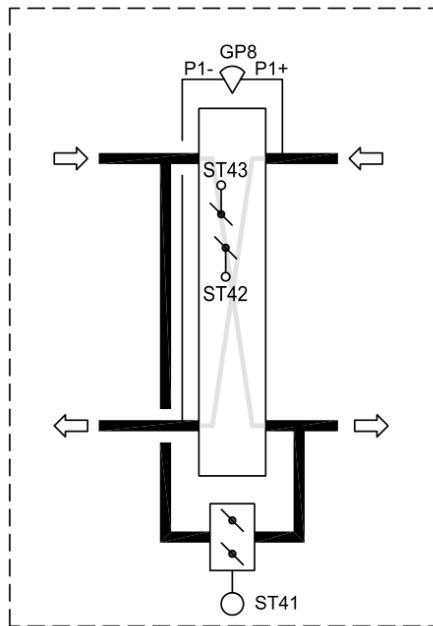

ST4 1	5922	Heat recovery output signal
ST42	11521	Heat recovery output signal defrost damper
ST43	46813	Heat recovery output signal defrost damper
GP8	31088	Act.pressure over Counterflow heat exchanger
	46503	Defrost Active
	64168	Normal pressure calculated
	41115	Actual start pressure defrost
	36716	Actual stop pressure defrost

Plate heat exchanger

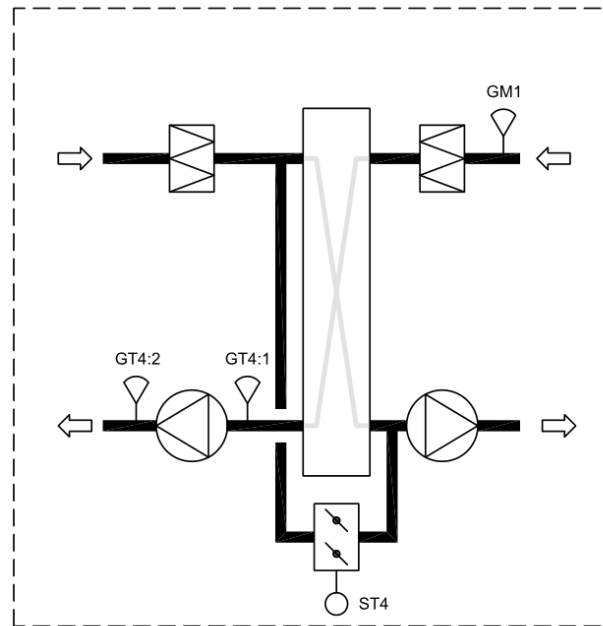

ST4	5922	Heat recovery output signal
GM1	37799	Room humidity relative (%)
GT4:1	33725	Cold corner
GT4:2	40895	Extract air temperature

Coil heat exchanger (Run-around coil)

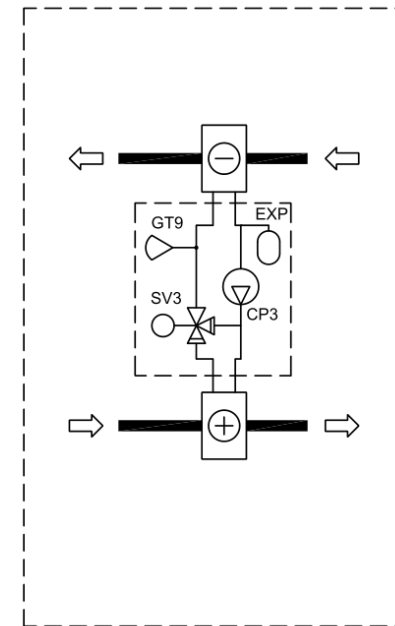

SV3	5922	Heat recovery output signal
CP3	59969	Heat recovery (pump) command
GT9	12446	Heat recovery water temperature
CP3	18003	Heat recovery pump alarm

Black	Value/State
Red	Alarm