

---

# Operation and Maintenance

## NEW EcoHeater 060-300



Order number:

Project:



# Unit specifications

## Unit parts and accessories

Damper (code EMT-01)

Sound attenuator (code EMT-02)

Combustion gas bypass (code EHP-B)

## Size

060	100	150
190	240	300

## Filter

Coarse-65% (G4)

ePM10-60% (M5)

ePM2.5-50% (M6)

ePM1-50% (F7)

ePM1-70% (F8)

ePM1-85% (F9)

ePM1-70% (C7)

Aluminium



# Table of Contents

<b>1</b>	<b>Safety precautions</b>	
1.1	Lockable safety switch .....	4
1.2	Inspection doors .....	4
1.3	Electrical connection .....	4
1.4	Compressor section .....	4
<b>2</b>	<b>General</b>	
2.1	Intended use .....	5
2.2	Manufacturer .....	5
2.3	Designations .....	5
2.4	CE marking and EU Declaration of Conformity .....	6
2.5	Maintenance .....	6
2.6	Handling of refrigerant .....	6
2.7	Extended warranty .....	7
2.8	Spare parts .....	7
2.9	Dismantling and decommissioning .....	7
<b>3</b>	<b>Technical description</b>	
3.1	Design .....	8
3.2	Function .....	9
<b>4</b>	<b>Wiring instructions and fuse protection</b>	
4.1	Wiring diagrams .....	12
4.2	Recommended fuse protection and power supply .....	12
4.3	Wiring instructions .....	13
<b>5</b>	<b>Operation</b>	
5.1	Commissioning .....	14
5.2	Commissioning combustion gas bypass .....	15
<b>6</b>	<b>Maintenance instructions</b>	
6.1	Service schedule .....	16
6.2	Filters (code ELEF) .....	17
6.3	Fan unit (code ENF) .....	20
6.4	Damper (code EMT-01) .....	23
6.5	Combustion gas bypass (code EHP-B) .....	24
6.6	Sound attenuator (code EMT-02) .....	25
6.7	Compressor section (code EHP-C) .....	26
<b>7</b>	<b>Troubleshooting</b>	
7.1	Troubleshooting in the event of an alarm .....	28
7.2	Troubleshooting via symptoms and status message .....	29
7.3	Alarm reset .....	30



# 1 Safety precautions

Observe warning labels on the unit as well as the following safety precautions:

## 1.1 Lockable safety switch



**WARNING!**

High voltage and rotating fan impeller, risk of personal injury. Working on/servicing the unit – Shut down the unit via the service switch in the control equipment, then turn the safety switch to the 0 position and lock it.

---

**NB:**

The safety switch is not designed for starting/stopping the unit. Always use the service switch in the control equipment to start and shut down the unit.

---

## 1.2 Inspection doors



**WARNING!**

Positive pressure inside the unit, risk of personal injury. Allow the pressure to drop before you open the inspection doors.

---



**WARNING!**

Rotating fan impeller, risk of personal injury. Shut down the unit via the service switch in the control equipment, then turn the safety switch to the 0 position and lock it. Wait at least 3 minutes before opening inspection doors.

---

**NB:**

The doors in front of moving parts should normally be locked; there are no safety guards. Before carrying out work, unlock the doors with the key provided.

---

## 1.3 Electrical connection



**WARNING!**

Rotating fan impeller, risk of personal injury. The unit must not be energised until all ducts have been connected.

---

**NB:**

Wiring of connections and other electrical work may only be carried out by a qualified electrician or by service personnel recommended by IV Produkt.

---

## 1.4 Compressor section



**WARNING!**

Hot surfaces, risk of personal injury. Shut down the unit via the service switch in the control equipment, then turn the safety switch to the 0 position and lock it. Wait at least 30 minutes before opening the compressor inspection doors.

---

## 2 General

### 2.1 Intended use

The EcoHeater extract air heat pump is intended for energy recovery from the extract air in apartment blocks.

When installed indoors, the air handling unit must be installed in an area that maintains a temperature between +7 and +30°C, and with a moisture content of <3.5 g/kg in the fan room in winter. The unit can also be equipped for installation in cold attics or outdoors.

Any other use and installation in other environments are prohibited unless specifically permitted by IV Produkt AB.

### 2.2 Manufacturer

The EcoHeater extract air heat pump is manufactured by:

IV Produkt AB  
Sjöddevägen 7  
SE-350 43 VÄXJÖ

### 2.3 Designations

The EcoHeater extract air heat pump comprises two sections, a fan section and compressor section, as well as a possible combustion gas bypass.

Each section has a model identification label placed on the front.

The model type plate shows the series number and the requisite designations to identify the section.

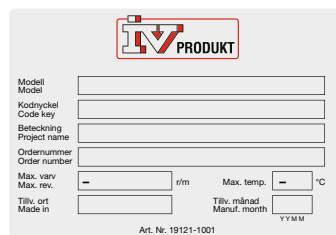

The image shows a typical model identification label form. It features the IV PRODUKT logo at the top center. Below the logo, there are several input fields for the following information: Modell (Model), Kodnyckel (Code key), Beteckning (Project name), and Ordernummer (Order number). There are also fields for Max. varv (Max. rev.) and Max. temp. (Max. temp.) with units r/m and °C, and fields for Tillv. ort (Made in) and Tillv. månad (Manuf. month) with a YMM format. At the bottom, the article number Art. Nr. 19121-1001 is printed.

*Typical model identification label*

## 2.4 CE marking and EU Declaration of Conformity

EcoHeater extract air heat pumps are CE marked, which means that upon delivery, they conform to applicable provisions in EU Machinery Directive 2006/42/EC as well as to the EU Directives applicable to other types of air handling units, e.g. the Pressure Equipment Directive.

As certification confirming that the requirements have been met, we provide an EU Declaration of Conformity, which is available under Documentation at [ivprodukt.docfactory.com](http://ivprodukt.docfactory.com), or under Order unique documentation at [docs.ivprodukt.com](http://docs.ivprodukt.com).



*Typical CE label for air handling units*

## 2.5 Maintenance

The ongoing maintenance of this unit can be carried out either by the person normally in charge of maintaining the building or through a contract with a well-reputed service company. Service and repair of the refrigerant circuit are carried out by a certified refrigeration technician.

## 2.6 Handling of refrigerant

The following information summarises the requirements and guidelines for handling the refrigerant used in cooling units. For further information, see the F-gas Regulations.

The unit is marked with the amount of refrigerant and carbon dioxide equivalent, alternatively see [docs.ivprodukt.com](http://docs.ivprodukt.com) (Technical data).

### Operator responsibilities

By operator, we refer to the European Parliament's definition: "...the natural or legal person exercising actual power over the technical functioning of the equipment and systems...".

Generally speaking, the unit operator must:

- Minimise and prevent leakage
- Take corrective action to remedy any leakage that arises
- Ensure that the service and repair of the refrigerant circuit are carried out by a certified refrigeration technician
- Ensure that refrigerant is handled in an environmentally secure manner and in accordance with national regulations.

## Leakage inspection and registration

For size 060-190 no further actions are needed beyond operator responsibility, see "Operator responsibilities" page 6.

For size 240-300:

- **Leakage inspection** must be conducted by a certified refrigeration technician:  
during installation/commissioning  
periodically at least once per 12 months between inspections  
within one month after any work is performed (for example tightening a leak or replacing components).
- The operator must **record** events, such as the volume and type of refrigerant topped up, refrigerant taken into possession, results of inspections and work done, person and company who carried out service and maintenance.

## 2.7 Extended warranty

In cases in which the equipment delivered falls under a 5-year warranty, in accordance with ABM 07 with supplement ABM-V 07 or in accordance with NL 09 with supplement VU13, the IV Produkt Service and Warranty Manual is supplied with the product.

In order to lay claim to an extended warranty, a complete, documented and signed IV Produkt Service and Warranty Manual must be presented.

## 2.8 Spare parts

Spare parts and accessories for this unit are ordered from your nearest IV Produkt sales representative. When ordering, state the order number and designation. These are stated on a model type plate, affixed to each component. There is a separate spare parts list for the unit, refer to Order Unique Documentation at [docs.ivprodukt.com](https://docs.ivprodukt.com).

## 2.9 Dismantling and decommissioning

When an air handling unit is to be dismantled, separate instructions must be followed, see [Dismantling and decommissioning the AHU](#) under Documentation at [ivprodukt.docfactory.com](https://ivprodukt.docfactory.com).

## 3 Technical description

### 3.1 Design

The EcoHeater extract air heat pump comprises two sections, a fan section and compressor section.



*Fan section*

*Compressor section*

#### Fan section

The fan section has a direct driven chamber fan with an EC motor and deep-ridged filter. EcoHeater sizes 240 and 300 have double fans. The fan unit is with-drawable. Replace the filter from the front of the unit.

#### Compressor section

The compressor section comprises a DX heat recovery coil, electronic expansion valve, a variable speed controlled compressor, fully soldered plate heat exchanger (between refrigerant and the liquid side), frost-protected evaporation water outlet for outdoor operation, and integrated control equipment with electrical connection.

The cooling circuit is integrated in the compressor section. The compressor and control components are shielded from the extract air stream. The cooling circuit is factory tested and built in accordance with PED 2014/68/EU, Module A2. Designed in accordance with EN378.

The cooling circuit is supplied with a high-pressure switch, as well as protection and alarm functions for high/low pressure. The cooling circuit is controlled so freezing does not occur in the extract air coil. Refrigerant is R410a.

All piping and electrical connections are made via the front. Frost protection (heating wire) for the condensation outlet is a maximum of 1 metre from the EcoHeater's casing for outdoor operation.



## 3.2 Function

### General

The incoming water to the EcoHeater must be at least 20 °C to ensure the operational safety of the EcoHeater.

Recovered energy is returned to the property's heating system.

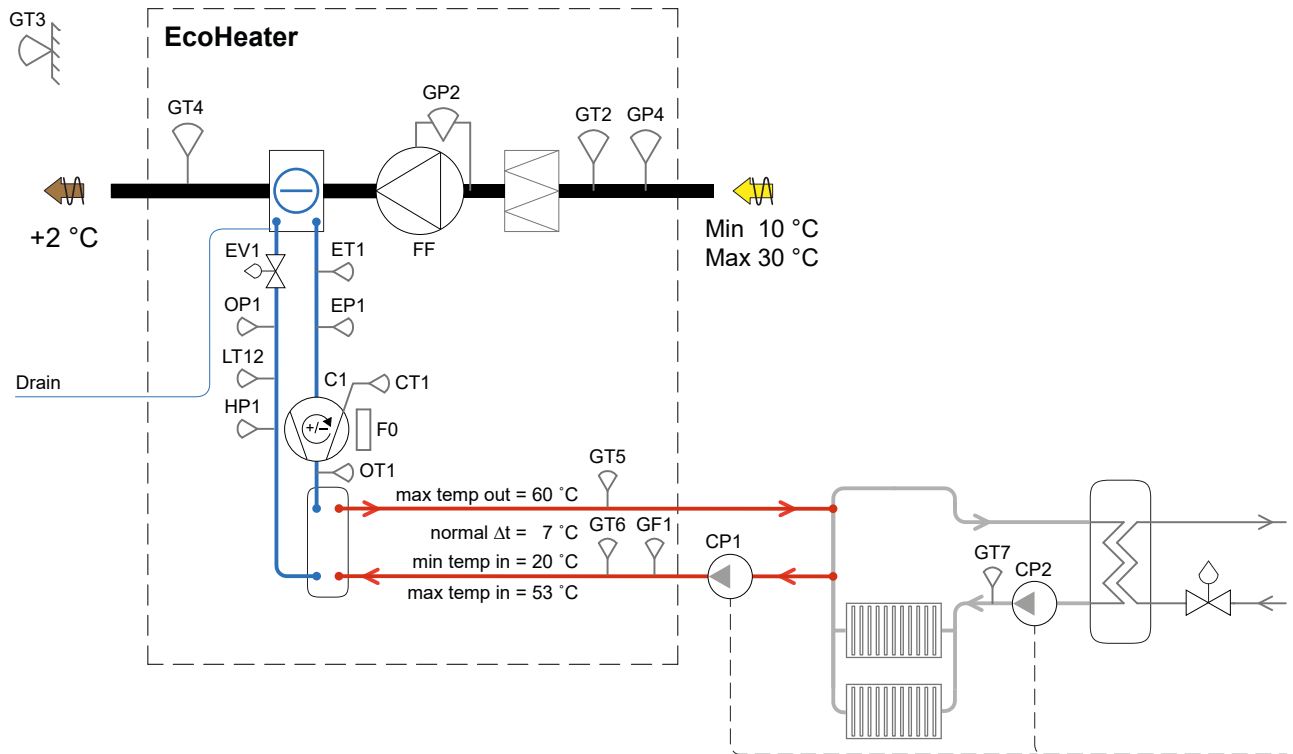

C1	Compressor, variable speed controlled
Drain	Condensate drain, frost protected (for outdoor configuration)
EP1	Low-pressure sensor cooling circuit
ET1	Pressure sensor cooling circuit suction gas
CT1	Temperature sensor compressor sump
LT12	Temperature sensor liquid line
EV1	Expansion valve, electronic
F0	Frequency inverter for compressor
EA	Extract air fan, variable speed controlled
GF1	Water flow sensor
GP4	Pressure extract air duct

GT2	Temperature sensor extract air
GT3	Temperature sensor outdoor air (north-east location)
GT4	Temperature sensor exhaust air
GT5	Temperature sensor water out
GT6	Temperature sensor water in
OT1	Temperature sensor hot gas
HP1	High-pressure switch
OP1	High-pressure sensor cooling circuit
CP2	Circulation pump radiator circuit
CP1	Circulation pump heat pump
GT7	Temperature sensor radiator circuit (for internal control only, not used for external control 0 – 10 VDC).

## Control

The EcoHeater has a factory-set time programme for continuous operation at one speed. The time programme can be changed on the Climatix display for control at up to three fan speeds.

- In case of malfunction of FF (extract air fan), an alarm sounds and the unit stops.
- The EcoHeater must be interlocked via circulation pump CP1.
- If GT6 (temperature sensor water in) registers a temperature that is too high, the compressor stops. It restarts automatically when the temperature falls to the permitted value.
- If EP1 (pressure sensor cooling circuit) and/or GT4 (temperature sensor exhaust air) register a temperature that is too low, the compressor's speed is reduced until the temperature reaches the permitted value.
- If OP1 (high-pressure sensor cooling circuit) registers a condensation temperature that is too high, the speed of the compressor is reduced.
- If GT4 (temperature sensor exhaust air) is lower than 12 °C, the compressor cannot be started.
- If GT4 (temperature sensor exhaust air) is more than 3 °C lower than GT2 (temperature sensor extract air), the compressor cannot be started.
- If GF1 (water flow sensor) registers too low flow, the compressor cannot be started. Restart occurs automatically when the permitted flow is reached.

## Compressor protection

In case of an alarm from FI (frequency inverter) or HP1 (high-pressure switch), the compressor stops. The high-pressure switch is reset manually.

## Temperature control

Temperature control to EcoHeater can be controlled via external control signal (0-10 VDC from sub-central unit, for example, district heating central), internal radiator curve or based on accumulation tank temperature, so that full capacity from the unit is utilised before the property's alternative energy sources are used.

## Pressure control

Pressure control can be used by GP4 maintaining a constant pressure in the extract air duct. The current air flow can be read on the Climatix display.

If the duct pressure deviates from the setpoint after a set time, an alarm sounds.

## Smoke/fire

If GT2 (temperature sensor extract air) registers a temperature higher than the set alarm limit, a smoke/fire alarm sounds.

## Communication

Communication via Modbus TCP/IP and text-web included as standard.

## Current limiting

The EcoHeater is equipped with a function that measures the compressor's power consumption. The power consumption can be limited to an adjustable value. If the unit is connected to a fuse that is less than the one recommended, this function should be used. For recommended fuse protection, refer to [docs.ivprodukt.com](https://docs.ivprodukt.com) (Technical Data).

To activate the function, do the following on the Carel control unit:

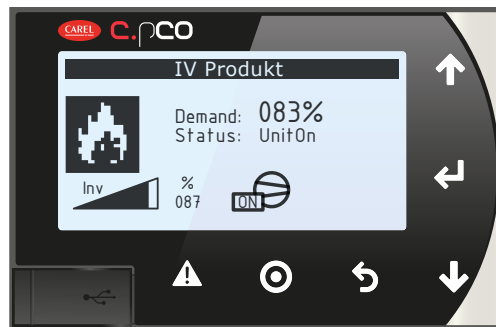

1. Press the circle button.
2. Press the down arrow to highlight status – I/O.
3. Press the enter button.
4. Press the up arrow to access the “Current limit” menu.
5. Press the enter button so that the cursor starts flashing.
6. Press the up arrow to change “NO” to “YES”.
7. Press the enter button so that the cursor starts flashing on the row below.
8. Use arrow up/down to set the compressor's maximum power consumption. Reduce the size of the fuse with the fans' power consumption, refer to order unique documentation at [docs.ivprodukt.com](https://docs.ivprodukt.com) (Technical Data), or the product selection program IV Produkt Designer.
9. Press the enter button.
10. Press the back arrow button twice to return to the start menu.



## 4 Wiring instructions and fuse protection

### 4.1 Wiring diagrams

For wiring diagrams, see order-unique electrical diagrams enclosed with the delivery of a unit or on [docs.ivprodukt.com](https://docs.ivprodukt.com) (Control diagram).

### 4.2 Recommended fuse protection and power supply

Power supply is connected to the switch in the compressor section.

For recommended fuse protection and power supply, refer to [docs.ivprodukt.com](https://docs.ivprodukt.com) (Technical Data).

### 4.3 Wiring instructions

#### Option 1 - Temperature control external 0-10 VDC (code STA-08)

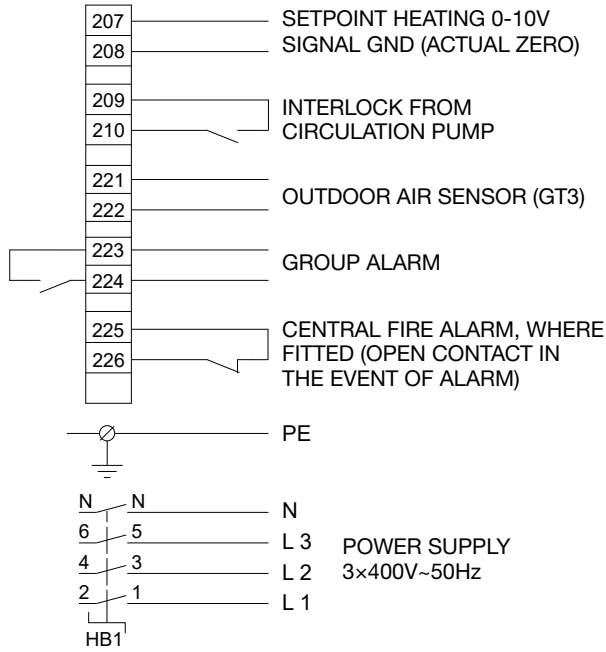

#### Option 3 - Temperature control of accumulation tanks (code STA-10)

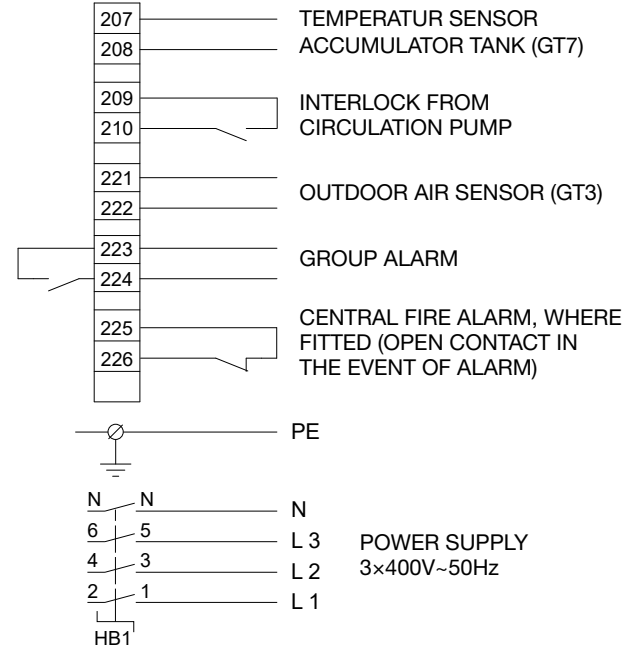

#### Option 2 - Temperature control internal radiator curve (code STA-09)

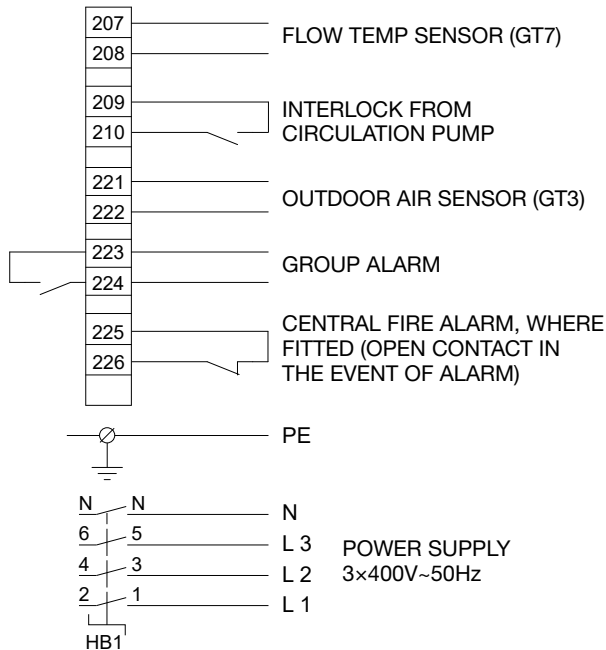

## 5 Operation

### 5.1 Commissioning

Commissioning of the unit must be carried out by competent personnel in accordance with the separate checklist:

[THE NEW EcoHeater, Start-up checklist](#)

and according to the separate commissioning protocol:

[EcoHeater, Commissioning report](#)

The documents can be downloaded from [ivprodukt.docfactory.com](http://ivprodukt.docfactory.com).

The validity of the product warranty is conditional on the system having been commissioned correctly. Working on the unit during the warranty period without the approval of IV Produkt shall render the warranty void.

The unit was designed and manufactured based on given operation cases that must comply with the unit's use for optimal function and a good operating economy.

External circumstances should not be changed without checking that such changes are within the unit's intended area of operation.

When commissioning EcoHeater for an occupied property, the fan section must be started immediately after installation to avoid disruption to the property's ventilation. The compressor section is then commissioned separately.

---

**NB!**

**It is important that the oil inside the speed-controlled compressor crankcase is warm before starting the heat pump. The crankcase heating must be switched on long enough before the unit begins operating so that the oil maintains a temperature of at least 30 °C. The maximum warm-up time is approximately 2–3 hours. The temperature can be measured externally at the bottom of the compressor.**

---

Prior to commissioning, the contractor must:

---

**NB:**

**Wiring of connections and other electrical work may only be carried out by a qualified electrician or by service personnel recommended by IV Produkt.**

---

1. Connect the unit to the power supply via a lockable safety switch.
2. Connect all ducts.

**WARNING!**

**Rotating fan impeller. The unit must not be energised until all ducts have been connected.**

---

Follow the troubleshooting instructions in the troubleshooting chart before contacting a service representative for servicing a unit under warranty. This will prevent any unnecessary service calls.

## 5.2 Commissioning combustion gas bypass

If the EcoHeater is equipped with a combustion gas bypass, check that the combustion gas bypass:







1. Is connected to the unit's fan section and connected according to the wiring instructions, see order-unique wiring diagrams enclosed with the delivery of the unit or on [docs.ivprodukt.com](https://docs.ivprodukt.com) (Control diagram).
2. Shows Control *Send* and Return.open mode *Yes* on the Climatix display (**Main menu > Unit > Damper control > Fire damper**). If error messages are displayed, address any errors.
3. Has a working end position function. Go to Start manual test on the Climatix display (**Main menu > Unit > Damper control > Fire damper - Start manual test**). Select *Active*. If error messages are displayed, address any errors and restart the test.

## 6 Maintenance instructions

### 6.1 Service schedule

The service schedule comprises actions and service intervals for functional sections that may be part of the EcoHeater extract air heat pump. The unit consists of one or more of these functional sections. For the parts that come into question, refer to order unique documentation at [docs.ivprodukt.com](http://docs.ivprodukt.com) (Technical Data).

Make copies of the service schedule for future use before you fill in servicing data for the first time.

Service year 20..... - ..... or unit no. ....				Service performed * (date and signature)			
Functional section	Code	Recommended action (insp.)	Page ref.	12 mths	24 mths	36 mths	48 mths
				date	date	date	date
 <b>Filter</b>	ELEF	Check pressure drop Change filter if necessary	17	signature	signature	signature	signature
 <b>Fan unit</b>	ENF	Visual inspection Clean if necessary Check the air flow	20	signature	signature	signature	signature
 <b>Damper</b>	EMT-01	Visual inspection Clean if necessary Check tightness	23	signature	signature	signature	signature
 <b>Combustion gas bypass</b>	EHP-B	Visual inspection Clean if necessary Check tightness	24	signature	signature	signature	signature
		Check function	15	signature	signature	signature	signature
 <b>Sound attenuator</b>	EMT-02	Visual inspection Clean if necessary	25	signature	signature	signature	signature
 <b>DX heat recovery coil</b>	EHP-C	Visual inspection Check drainage. Clean if necessary Check function	26	signature	signature	signature	signature
		<b>Cooling circuit</b>	Periodic inspection	6			

\*More frequent servicing may be required in certain environments. Replace the filter if the pressure drop across the filter exceeds the specified final pressure drop.



## 6.2 Filters (code ELEF)

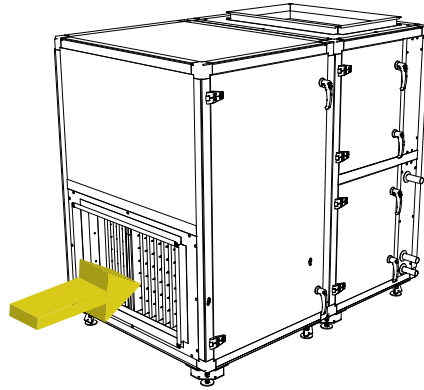

The air filter protects sensitive components inside the unit, such as the heat recovery coil, from exposure to impurities.

The dust separation efficiency varies considerably between various filter types. The dust collecting efficiency also varies substantially. Use filters of the same quality and capacity when you change them.

The filters are designed for one-time use. If they become clogged, the unit will lose capacity.

### Filter data

For filter data, refer to [Filter Overview](#) under Documentation at [ivprodukt.docfactory.com](http://ivprodukt.docfactory.com). For current filters, see order-unique documentation on [docs.ivprodukt.com](http://docs.ivprodukt.com) (Technical Data and Parts List).

## Inspection

Check the pressure drop across the filter. The pressure drop is measured with a pressure gauge connected to the measurement outlets. The measurement outlets are connected to each side of the filter.

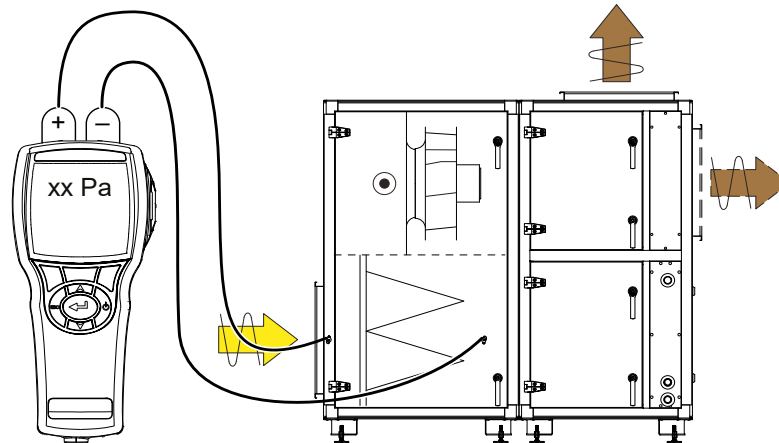

The filter should be changed if the pressure drop across them exceeds the specified final pressure drop. It is important to stop the unit before changing filters to prevent dust from coming loose and being drawn into the unit. Also carry out a visual inspection of the filter for damage and deposits.

The final pressure drop is specified on the filter section decal (filled in when the air handling unit is put into operation).

FILTERDATA	
Nominellt luftflöde	<input type="checkbox"/> m <sup>3</sup> /s
Nominal air flow.....	<input type="checkbox"/> m <sup>3</sup> /h
Antal filter	Mått
Number of filters.....	Dimensions.....
.....	.....
.....	.....
Filterklass/Filter Class.....	
Begynnelsestryckfall	
Initial Pressure Drop.....	.....Pa
Sluttryckfall	
Final Pressure Drop.....	.....Pa

Art. Nr: 19121-1101\_02SV

## Filter replacement

1. Shut down the unit via the service switch in the control equipment, then turn the safety switch to the 0 position and lock it.

**NB!**

**The safety switch is not designed for starting/stopping the unit. Always use the service switch in the control equipment to start and shut down the unit.**

2. If a filter monitor has been installed, disconnect the requisite measurement cables to the hatch/post in order to open the inspection hatch.
3. Wait until the fans have stopped, then open the inspection hatch.



**WARNING!**

**Positive pressure inside the unit, risk of personal injury. Allow the pressure to drop before you open the inspection doors.**

4. Release the eccentric rails.

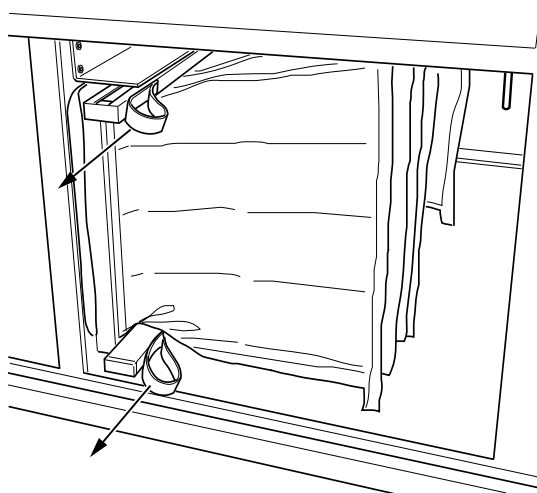

*Eccentric rails*

5. Remove the old filter by pulling it towards you. Discarded filters should be disposed of correctly. The filter is completely combustible.
6. Clean the filter cabinet.
7. Install the new filter, press in the eccentric rails to engage them and close the inspection hatch.
8. If a fixed filter monitor has been installed, reconnect the measurement cables to the metering sockets on the hatch/post.
9. Start the unit.

### 6.3 Fan unit (code ENF)

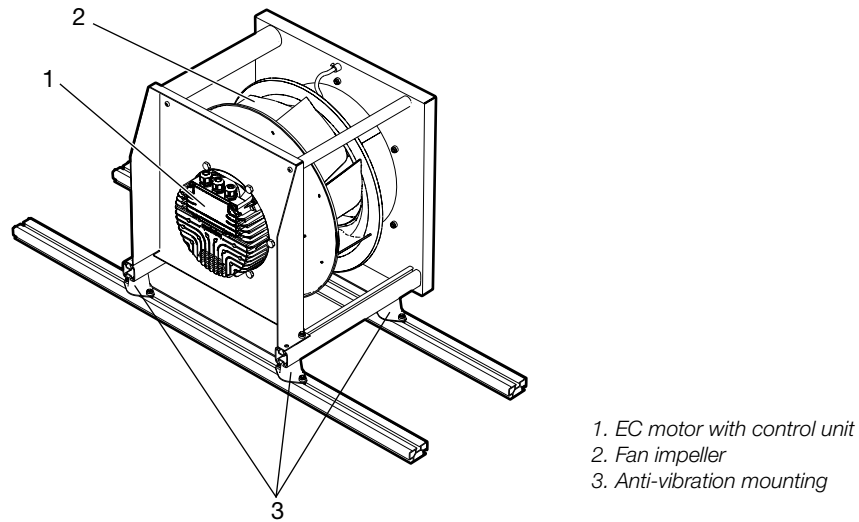

The fan transports air through the system. The fan shall overcome the flow resistance found in air diffusers, ducts and units.

The fan speed is regulated to provide correct air flow. If the fan generates a lower air flow, this will impair the function of the ventilation system.

- If the extract air flow is too low, the ventilation capacity will be unsatisfactory.
- If a centrifugal fan is rotating in the wrong direction, the air flow will still go the right way, but with a considerable reduction in capacity. Therefore check the direction of rotation.

## Inspection

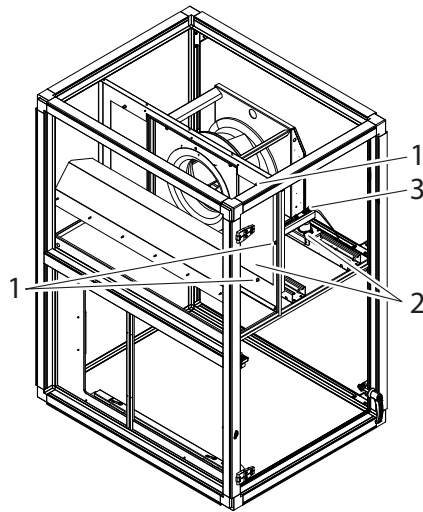

- 1. Screws
- 2. Pins/screws
- 3. Earth braid



**WARNING!**

High voltage and rotating fan impeller, risk of personal injury. Working on/servicing the unit – Shut down the unit via the service switch in the control equipment, then turn the safety switch to the 0 position and lock it.



**WARNING!**

Rotating fan impeller, risk of personal injury. Shut down the unit via the service switch in the control equipment, then turn the safety switch to the 0 position and lock it. Wait at least 3 minutes before opening inspection doors.



**WARNING!**

Positive pressure inside the unit, risk of personal injury. Allow the pressure to drop before you open the inspection doors.

1. Fan and motor are mounted on slide rails. Loosen screws (1), pins/screws (2), and the earth braid (3) and pull out the fan unit.
2. Check that the fan impeller rotates easily, is in balance and does not vibrate. Also check that the fan impeller is clean from any accumulation of particles. Imbalance may be due to a coating or damage to the fan impeller blades.
3. Listen to the sound from the motor bearings. If the bearings are in good condition, you will hear a slight purring sound. A scraping or pounding sound may mean that the bearings are damaged and service is then required.
4. Check that the fan impeller is fixed and overlaps the inlet cone.
5. The fan impeller and motor are mounted on a support fitted with rubber anti-vibration mountings. Check that the anti-vibration mountings are securely mounted and are intact.
6. Check the mounting screws as well as the suspension devices and support.
7. Check that the gaskets on the connection plates around the connection openings are intact and firmly fitted.
8. Check that the measurement tubes are securely fitted on each measurement outlet.
9. Refit the fan unit and earth braid.



## Cleaning

1. Follow the safety instructions and paragraph 1 under **Check**.
2. Wipe the fan impeller blades to remove any coatings. Use an environmentally friendly degreasing agent.
3. The external surfaces of the motor must be kept clean from dust, dirt and oil. Clean with a dry cloth. In the event of heavy soiling, use an environmentally friendly degreasing agent. The motor is likely to overheat inside if thick layers of dirt prevent air from entering the motor to cool the stator structure.
4. Vacuum the unit so that dust is not blown out into the duct system.
5. Clean the other parts in the same way as the fan impellers. Check that the inlet cones are securely mounted.
6. Refit the fan unit and earth braid.

## Resetting the overheat protection

1. Cut the power supply to the fan motor.
2. Wait at least 20 seconds after the fan impeller has stopped rotating.
3. Close the power supply to the fan motor.

## 6.4 Damper (code EMT-01)

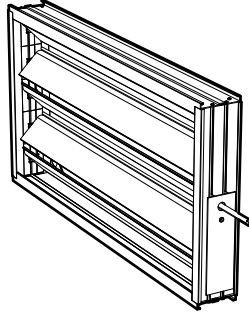

The purpose of the dampers is to regulate the air flow. Faulty function gives rise to disturbances that may result in serious problems.

If the damper does not:  
open completely, the air flow is  
reduced (leaks) leading to increased energy use.

### Inspection

1. Check the function of the damper actuator.
2. Check that damper tightens when closed. If they are not sealed, adjust the damper actuator to make the damper tight.
3. Check the sealing strips.
4. If the damper is not working, check that there are no screws penetrating the drive mechanism/damper blades to interfere with damper function.

### Cleaning

Clean the damper blades with a cloth. In the event of heavy soiling, an environmentally friendly degreasing agent can be used.

## 6.5 Combustion gas bypass (code EHP-B)

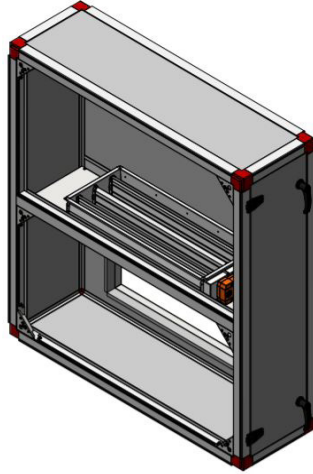

The purpose of the combustion gas bypass is to reroute the air flow in the event of a fire. Faulty function gives rise to disturbances that may result in serious problems.

### Inspection

1. Check the function of the damper actuator.
2. Check that damper tightens when closed, follow point 3 under "Commissioning combustion gas bypass" on page 15. If they are not sealed, adjust the damper actuator to make the damper tight.
3. Check the sealing strips.
4. If the damper is not working, check that there are no screws penetrating the drive mechanism/damper blades to interfere with damper function.

### Cleaning

Vacuum and/or wipe all surfaces with a damp cloth. In the event of heavier soiling, rotating nylon brushes can be used.



## 6.6 Sound attenuator (code EMT-02)

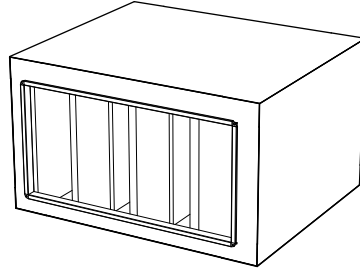

The purpose of the sound attenuator is to reduce the sound power level in the system.

### Inspection

Check that the baffle elements are intact and have clean surfaces. Take action if necessary.

### Cleaning

Vacuum and/or wipe all surfaces with a damp cloth. In the event of heavier soiling, rotating nylon brushes can be used.



## 6.7 Compressor section (code EHP-C)

### Periodic inspection

The operation parameters for the extract air heat pump must not be changed unless a check is first made to ascertain that the changes will be within the unit's operating range.

### Leakage inspection and registration

For information on the operator's responsibility with regards to leakage inspection and registration, see "2.6 Handling of refrigerant" page 6. For access to the cooling circuit and compressor, see "Access to the cooling circuit and compressor" page 27.

### Inspection

Check:

1. The coil fins to detect possible mechanical deformity
2. the drip tray and drain (clean if necessary)
3. frost protection for outlet pipes
4. traces of oil residues, which may indicate leakage on the refrigerant circuit. For service and repair of the refrigerant circuit call a certified refrigeration technician.

### Cleaning

If the fins on the coil are dirty, vacuum clean from the inlet side. Exercise care when vacuuming, as the fins are thin and can be damaged through careless contact. Alternatively, you can blow them clean with compressed air from the outlet side. In the event of heavy soiling, you can clean them with warm water mixed with dishwashing detergent that will not corrode aluminium.

For more information refer to heavy soiling under Documentation at [ivprodukt.docfactory.com](http://ivprodukt.docfactory.com).

## Access to the cooling circuit and compressor

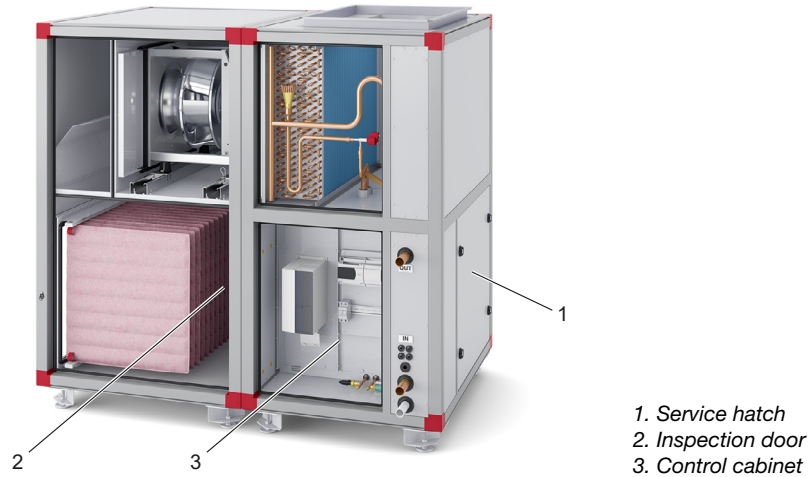

### **WARNING!**

**Hot surfaces, risk of personal injury. Shut down the unit and wait at least 30 minutes before opening the inspection doors to access the compressor.**

### **Access via the inspection hatch**

1. Shut down the unit via the service switch in the control equipment, then turn the safety switch to the 0 position and lock it.
2. Remove the filter for access. See “Filter replacement (ELEF)” on page 17.
3. Open the inspection hatch.
3. Close the inspection door after completing the service operation.

### **Access via the service hatch**

1. Shut down the unit via the service switch in the control equipment, then turn the safety switch to the 0 position and lock it.
2. Remove the service hatch.
3. Close the service hatch after completing the service operation.

### **Access via the control cabinet**

1. Shut down the unit via the service switch in the control equipment, then turn the safety switch to the 0 position and lock it.
2. Open the control cabinet door.
3. Remove the frequency inverter and plates. Fold the circuit board to the side.
4. Reassemble parts after completing the service operation.

## 7 Troubleshooting

### 7.1 Troubleshooting in the event of an alarm

Alarm information is read out on the Carel display. Press the alarm symbol to view alarms.

Inspection	Possible cause	Corrective action
Is the alarm "94 Drive offline" displayed?	YES The frequency inverter does not ⇒ have supply voltage 3×400 V	Check the supply voltage to the frequency inverter.  Check fuses.  Check cabling for communication between the frequency inverter and Carel control panel.
NO ↓		
Has the high-pressure switch tripped? Is the alarm "121 Compr 1, High-pressure switch" or "180 Compr 1, High-pressure switch" displayed?	YES No or too low flow of water ⇒ across the condenser  Defective high-pressure switch	Check the flow of water across the condenser.  Rest the pressure switch manually.  Check/replace.
NO ↓		
Is the alarm "118 Compr 1, Low evaporation pressure" displayed?	YES Insufficient refrigerant volume ⇒  No or too low air flow across the heat recovery coil  Defective expansion valve	Look for leakage, seal the leak and top up with refrigerant. For requirements and guidelines for handling refrigerant, see "2.6 Handling of refrigerant" page 6.  Check/adjust the flow.  Check/replace.
NO ↓		
Is the LED flashing red on the frequency inverter?	YES Phase failure/voltage failure ⇒  Overload/defective stepless compressor	Check the 3-phase supply, measure the incoming voltage. Reset the frequency inverter by switching off the voltage for 1 minute or more. Check that the compressor is running without dissonance.  Reset the frequency inverter by switching off the voltage for 1 minute or more. Check that the compressor is running without dissonance.
NO ↓		
Is the alarm "AL 120 Compr 1 Low pressure diff." displayed?	YES No pressure difference between ⇒ the high-pressure and low-pressure side	Contact service.
NO ↓		
Is the alarm "AL 59 Compr 1 Low Cond Temp" displayed?	YES Condensation temperature too ⇒ low	Incoming water to EcoHeater must be at least 20 °C. Check the water temperature.

## 7.2 Troubleshooting via symptoms and status message

Status information is read on the Climatix display.  
**(Main menu > Unit > Heat pump > Status heat pump).**

Symptom	Status message	Possible cause	Corrective action
The compressor speed drops	HiPress	<ol style="list-style-type: none"> <li>Insufficient water flow through the heat pump.</li> <li>High return water temperature to the heat pump.</li> </ol>	<ol style="list-style-type: none"> <li>Adjust the water flow.</li> <li>Check the incoming water temperature.</li> </ol>
	FrostTemp	The compressor speed is limited to prevent frost formation on the heat recovery coil.	Normal condition when the extract airflow is not high enough to run the compressor at maximum power.
Compressor does not start	OFFbyKey	Menu in Carel "On/Off Unit" is not set to ON	Set On to ON.
	OFFbyDIN	Interlock from Climatix missing.	Move CHANGEOVER SWITCH SERVICE to "Auto".
	UnitOn	<ol style="list-style-type: none"> <li>The demand indicator is lower than 10% (menu in Climatix "Heat demand").</li> <li>The start delay for the compressor has not counted down to 0.</li> </ol>	<ol style="list-style-type: none"> <li>Check external control 0 – 10 VDC, heat curve and temperature sensor outdoor air.</li> <li>Wait or jump start.</li> </ol>
	FrostTemp	<ol style="list-style-type: none"> <li>The difference between the return air temperature and extract air temperature is greater than 3°C (menu "End defrostdiff").</li> <li>The exhaust air temperature is lower than 12°C (menu "End temp min freq:").</li> <li>The compressor has stopped due to the evaporating temperature or exhaust air temperature having fallen below its respective minimum temperature at the compressor's lowest possible speed.</li> </ol>	<ol style="list-style-type: none"> <li>Wait until the exhaust air temperature has risen to the starting level.</li> <li>Jump start.</li> </ol> <ol style="list-style-type: none"> <li>Wait for the exhaust air temperature to rise.</li> <li>Check that the air flow is not too low.</li> </ol>
	Low water flow	Insufficient water flow through the compressor.	<ol style="list-style-type: none"> <li>Check that the circulation pump heat pump CP1 is running.</li> <li>Check that the water flow is in the correct direction.</li> </ol>



### 7.3 Alarm reset

In the event of an alarm initiated by the frequency inverter or the safety circuit, the compressor stops. The alarm is displayed on both Climatix and the Carel display.

In the event of an alarm, take corrective action to correct the fault, and then press the “Alarm reset” button on the Carel display for 3 seconds. If the safety circuit alarm trips repeatedly, an authorised refrigeration service company must be called in.



*Air handling with focus on LCC*

## **You are welcome to contact us**

---

Switchboard:	+46 (0)47 075 88 00	
Control support:	+46 (0)47 075 89 00	<a href="mailto:styr@ivprodukt.se">styr@ivprodukt.se</a>
Service:	+46 (0)47 075 89 99	<a href="mailto:service@ivprodukt.se">service@ivprodukt.se</a>
Spare parts:	+46 (0)47 075 88 00	<a href="mailto:spareparts@ivprodukt.com">spareparts@ivprodukt.com</a>
<b>Visit us at:</b>	<b><a href="http://www.ivprodukt.com">www.ivprodukt.com</a></b>	
Documentation for your unit:	<a href="http://docs.ivprodukt.com">docs.ivprodukt.com</a>	
Technical documentation:	<a href="mailto:docs@ivprodukt.se">docs@ivprodukt.se</a>	