

---

# Operation and Maintenance

## Envistar Top



Order number:

Project name:



# Unit specifications

## Unit type

TEM	TXM	TEXM
TER	TXR	TEXR
TEC-R	1V	2V
TEC-M		
TECX		
TECO		
TTC		
TTCH		

Home Concept Configuration

## Unit parts and accessories

Rotary heat exchanger TXRR

Counter-flow exchanger TXMM

Air heater water ETAB-VV

Output var           1           2           3

Air heater water SBK-VV

ThermoGuard ETAB-TV

Output var                                   1           2

Air heater electric ETAB-EV

Output var           1           2           3

Air heater electric ETKB-EV

Output var 1           2           3           4

Air heater electric ETAB-SV

Air cooler water ETKB-VK

Air cooler water/DX

Damper ETSP-UM, ETSP-TR, ETRL

Sound attenuator ETLD

## Size

04	06	09	10
12	17	22	28

## Control equipment

MX

UC

MK

US

HS

## Filter supply air

ePM10-60% / M5

ePM1-50% / F7

ePM1-60% / F7

Excl. filter

## Filter extract air

ePM10-60% / M5

ePM1-50% / F7

ePM1-60% / F7

Excl. filter



# Table of Contents

## 1 Security

1.1 Intended use .....	1
1.2 Unintended uses .....	1
1.3 Manufacturer .....	1
1.4 General safety .....	1
1.5 General safety notices .....	2
1.6 General safety messages .....	2
1.7 Signs on the unit .....	6
1.8 CE marking .....	7
1.9 Maintenance .....	7
1.10 Warranty .....	8
1.11 Extended warranty .....	8
1.12 Dismantling and decommissioning .....	8
1.13 Hygiene configuration (optional extra) .....	8

## 2 General

2.1 Information messages, not safety-related .....	9
2.2 Documentation and support .....	9
2.3 Spare parts .....	9

## 3 Handling of refrigerant

3.1 Responsibility .....	10
3.2 Use and inspection of pressurised equipment .....	10
3.3 Leakage control and registration .....	10

## 4 Technical description

4.1 Configuration of the unit .....	11
4.2 Home Concept Configuration .....	11
4.3 Detector system, refrigerant .....	11
4.4 Cooling unit EcoCooler (code TEC-R, TEC-M, TECO, TECX) .....	12
4.5 Reversible heat pump ThermoCooler HP (code TTC, TTCH) .....	16

## 5 Commissioning and operation

5.1 Prior to commissioning .....	19
5.2 Starting and stopping the unit .....	20
5.3 Before maintenance (switch off the unit) .....	20
5.4 Additional wiring instructions .....	21
5.5 Operating parameters, cooling .....	22

# Table of Contents, cnt'd

## 6 Maintenance instructions

6.1 Service schedule .....	33
6.2 Filters (code ELEF) .....	35
6.3 Rotary heat exchanger (code TXRR) .....	38
6.4 Counter-flow exchanger (code TXMM) .....	43
6.5 Air heater water (code ETAB-VV, SKB-VV) and Thermoguard (code ETAB-TV) .....	45
6.6 Air Heater electric (Code ETAB-EV, ETKB-EV, ETAB-SV) .....	47
6.7 Air cooler water (code ETKB-VK, SBK-VK) .....	49
6.8 Fan unit (code ELFF) .....	51
6.9 Damper (code ETSP-UM, ETSP-TR, ETRL) .....	55
6.10 Sound attenuator (code ETLT) .....	57
6.11 Cooling unit (code TEC-R, TEC-M, TECX, TECO). Reversible heat pump (code TTC, TTCH) .....	58

## 7 Alarm management and troubleshooting

7.1 Cooling unit size 17-22 (code TEC) .....	59
7.2 Cooling unit (size 06-12 code TEC-R) / (size 06, 10 code TEC-M) - without Carel .....	61
7.3 Cooling unit (size 04-12 code TEC-R) / (size 04-12 code TEC-M) / (size 17-28 code TECO, TECX) - with Carel. Reversible heat pump (code TTC, TTCH) .....	65

# 1 Security

This section addresses important safety aspects of assembly, with the aim of raising safety awareness and avoiding personal injuries and damage to surroundings and units.



- This manual contains important instructions. Read it carefully and follow the instructions.
- Pay special attention to warning and information messages, as well as markings on the product.
- Keep the manual for future use.

00177

## 1.1 Intended use

The air handling units in the Envistar Top series are intended for comfort ventilation in buildings.

### Intended users

The contents of this manual are intended for personnel who commission and carry out regular maintenance on the unit. Maintenance and servicing of the cooling unit/reversible heat pump must be carried out by a certified refrigeration technician.

### Intended user environment

When installed indoors, the unit must be installed in an area that maintains a temperature between +7 and +30°C, and with a moisture content of <3.5 g/kg in dry air in the winter. The unit can also be equipped for outdoor installation.

## 1.2 Unintended uses

Any use other than specified in the Intended Use section is prohibited unless specifically permitted by IV Produkt. It is not permitted to use the unit in potentially explosive environments.

## 1.3 Manufacturer

The Air Handling Unit is manufactured by IV Produkt AB, Sjöuddevägen 7, S-350 43 VÄXJÖ, Sweden.

## 1.4 General safety

Failure to comply with the safety precautions may result in injury to persons or damage to air handling units. To avoid personal injuries and damage to surroundings or units:

- Follow national and local laws/regulations for safe work, e.g. fall protection when working at a height.
- Do not wear loose clothing or jewellery that may get fasten.
- Do not step or climb on the unit.
- Use appropriate tools.
- Use appropriate personal protective equipment.
- Note the unit's markings: product signs, information and warning stickers.
- Make sure that all covers are in place, that inspection covers are closed and that lockable inspection covers are locked before starting the unit and after repairs/service.

## Personal Protective Equipment (PPE)

Personal protective equipment must always be used based on the risks present in the workplace. For example, wear protective footwear with steel toecaps, hearing protection, safety helmet, gloves, safety eyewear or goggles, fully-covering clothing, safety overalls, face mask/protective mask and/or fall protection where the work and work environment require it.

## 1.5 General safety notices

	<p><b>WARNING!</b>  <b>Risk of pinch injury, crush injury or cutting injury due to moving parts.</b>  <i>The device may start unexpectedly during remote control or demand-driven start-up.</i></p> <ul style="list-style-type: none"> <li>• Control parameters may only be changed by personnel with extended privileges.</li> <li>• The device must be turned off with all safety switches before covers can be opened.</li> </ul> <p style="text-align: right;">00257</p>
	<p><b>WARNING!</b>  <b>Risk of injury due to moving parts.</b>  <i>During operation, loose objects in the device can be ejected out and hit people who are in the vicinity of the device.</i></p> <ul style="list-style-type: none"> <li>• The device must not be energised until all channels have been connected.</li> <li>• No loose objects should be inside the device.</li> <li>• All inspection hatches should be closed and lockable covers should be locked during operation.</li> </ul> <p style="text-align: right;">00258</p>
	<p><b>WARNING!</b>  <b>Risk of personal injury due to high noise levels.</b>  <i>High noise levels can cause damage to hearing.</i></p> <ul style="list-style-type: none"> <li>• Check the noise level in the current operation point. See information in Technical Data for the unit in question.</li> <li>• Comply with local and national regulations for work at higher noise levels.</li> </ul> <p style="text-align: right;">00259</p>

## 1.6 General safety messages

Comply with the following general safety messages.

### Lockable safety switch

	<p><b>WARNING!</b>  <b>Risk of serious injury.</b>  <b>Electrical power can cause electric shock, burns and death.</b></p> <p><b>Working on/servicing the unit – Shut down the unit via the service switch in the control equipment, then turn the safety switch to the 0 position and lock it.</b></p> <p><b>There may be several safety switches serving the different parts of the unit. All safety switches must be switched off and locked before repairs/service.</b></p>
---	---



**BE CAREFUL!**

The safety switch is not designed for starting/stopping the unit. Always use the service switch in the control equipment to start and shut down the unit.

## Electrical connections



**WARNING!**

Risk of serious injury.  
Electrical power can cause electric shock, burns and death.

Working on/servicing the unit – Shut down the unit via the service switch in the control equipment, then turn the safety switch to the 0 position and lock it.

There may be several safety switches serving the different parts of the unit. All safety switches must be switched off and locked before repairs/service.



**WARNING!**

Risk of personal injury.  
Rotating fan impellers can cause crushing injuries or lacerations.  
The unit must not be energised until all ducts have been connected.



**BE CAREFUL!**

Wiring of connections and other electrical work may only be carried out by a qualified electrician or by service personnel recommended by IV Produkt.

## Inspection hatches



**WARNING!**

Risk of personal injury.  
Overpressure in unit.  
Allow the pressure to drop before you open the inspection doors.



**WARNING!**

Risk of personal injury.  
The doors in front of moving parts shall normally be locked; there are no contact guards.

During repairs/service, the inspection doors are locked with the supplied keys.

Make sure that all doors are in place, that inspection doors are closed and that lockable inspection doors are locked before starting the unit and after repairs/service.

## Cooling unit/Reversible heat pump



**WARNING!**

Risk of personal injury.  
Hot surfaces can cause burns.

Working on/servicing the unit – Shut down the unit via the service switch in the control equipment, then turn the safety switch to the 0 position and lock it.

There may be several safety switches serving the different parts of the unit. All safety switches must be switched off and locked before repairs/service.

Wait at least 30 minutes before opening the compressor inspection hatches.



**WARNING!**

Risk of fire in the event of a refrigerant leak.

A2L refrigerants are mildly flammable and can ignite in the event of a leak.

If external damage to the cooling circuit has led to a refrigerant leak, evacuate the ventilation room, ensure good ventilation, and call in a certified refrigeration technician.

Service of cooling units/reversible heat pumps may only be carried out by a certified refrigeration technician. Working on/servicing the unit – Shut down the unit via the service switch in the control equipment, then turn the safety switch to the 0 position and lock it.

There may be several safety switches serving the different parts of the unit. All safety switches must be switched off and locked before repairs/service.

Due to the risk of sparks, safety switches must not be used if there is a suspected refrigerant leak.

When detector system installed:

- Make sure the detector system is functioning.
- Make sure that external dampers in the ductwork do not block the unit's air flow through uncontrolled closing.



## Heating coil



**WARNING!**  
Risk of personal injury.  
Hot surfaces can cause burns.

**Working on/servicing the unit – Shut down the unit via the service switch in the control equipment, then turn the safety switch to the 0 position and lock it.**

**There may be several safety switches serving the different parts of the unit. All safety switches must be switched off and locked before repairs/service.**

**Wait at least 5 minutes before opening the battery inspection hatches.**

## Fan



**WARNING!**  
Risk of personal injury.  
Rotating fan impellers can cause crushing injuries or lacerations.

**Working on/servicing the unit – Shut down the unit via the service switch in the control equipment, then turn the safety switch to the 0 position and lock it.**

**There may be several safety switches serving the different parts of the unit. All safety switches must be switched off and locked before repairs/service.**

**Wait at least 3 minutes before opening inspection hatches.**

## Rotary heat exchanger



**WARNING!**  
Risk of personal injury.  
Rotating thermal wheels can cause crushing injuries or lacerations.

**Working on/servicing the unit – Shut down the unit via the service switch in the control equipment, then turn the safety switch to the 0 position and lock it.**

**There may be several safety switches serving the different parts of the unit. All safety switches must be switched off and locked before repairs/service.**

**Wait at least 3 minutes before opening inspection hatches.**

## Damper

	<p><b>WARNING!</b>                  Risk of personal injury.                  Moving parts can cause crushing injuries. Never place your hands inside the damper when it closes.</p> <p><b>Working on/servicing the unit – Shut down the unit via the service switch in the control equipment, then turn the safety switch to the 0 position and lock it.</b></p> <p><b>There may be several safety switches serving the different parts of the unit. All safety switches must be switched off and locked before repairs/service.</b></p> <p><b>Some dampers are closed via spring return in a de-energized state.</b></p> <p><b>Wait at least 3 minutes for the damper to close.</b></p>
---	---

## Filter

	<p><b>WARNING!</b>                  Risk of personal injury – harmful dust.                  Use a face mask/respiratory protection to avoid inhaling dust.</p>
--	---

## 1.7 Signs on the unit

Keep signs and stickers free of dirt. Replace missing, damaged or unreadable signs and stickers on the machine. Contact IV Product for replacement stickers by specifying the article number.

## Type plate

The unit and any associated cooling unit/reversible heat pump have a type plate affixed to the inspection side. The type plate is used, among other things, for identification of the product.



Example of a unit type plate

- |                       |                         |
|-----------------------|-------------------------|
| 1. Order number       | 5. Place of manufacture |
| 2. Product name/model | 6. Date of manufacture  |
| 3. Product code       | 7. QR code              |
| 4. Unit designation   |                         |

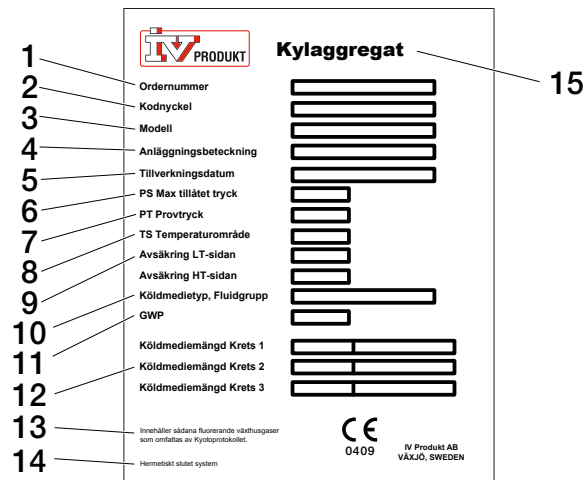

00351

Example of a cooling unit/reversible heat pump type plate

- |  |   |
|--|---|
| 1. Order number                        | 10. Refrigerant type, Fluid Group   |
| 2. Code key                            | 11. GWP   |
| 3. Model                               | 12. Refrigerant volume, Circuit 1, 2, 3, (kg, CO <sub>2</sub> e)  |
| 4. Plant designator                    | 13. Contains fluorinated greenhouse gases covered by the Kyoto Protocol.                                |
| 5. Date of manufacture                 | 14. Hermetically sealed system, applies to refrigerants R410A and R454B (not available for Easy Access) |
| 6. PS Max allowed pressure, bar (e)    | 15. Cooling unit/Reversible heat pump   |
| 7. PT Pressure test, bar (e)           |   |
| 8. TS Temperature range, °C            |   |
| 9. Fuse protection LT/HT side, bar (e) |   |

## 1.8 CE marking

The air handling unit is CE marked and meets the applicable requirements according to specified directives and standards in the Declaration of Conformity. The marking covers the unit in the configuration in which it was delivered and provided that it has been assembled and commissioned in accordance with IV Produkt's instructions. The declaration does not cover units that have been modified, retrofitted components, or other systems in which the unit may be included. The unit may not be put into service until the system, in which it is a component, complies with the applicable requirements for CE marking in the country where the unit is installed.

The Declaration of Conformity is available under Documentation at [ivprodukt.docfactory.com](http://ivprodukt.docfactory.com), or under Order Unique Documentation at [docs.ivprodukt.com](http://docs.ivprodukt.com).

## 1.9 Maintenance

Regular maintenance of this unit can be carried out either by the person normally in charge of maintaining the building or through a contract with a reputable service company. Maintenance and servicing of the cooling unit/reversible heat pump must be carried out by a certified refrigeration technician.

## 1.10 Warranty

For proper function and for the warranty to be valid, the assembly instructions must be followed. The validity of the product warranty is conditional on the system having been commissioned correctly. Working on the unit during the warranty period without the approval of IV Produkt shall render the warranty void.

## 1.11 Extended warranty

In cases in which the equipment delivered is covered by a 5-year warranty, in accordance with ABM 07 with appendix ABM-V 07 or in accordance with NL 17 with appendix VU20, the IV Produkt Service and Warranty Manual is supplied with the product.

In order to claim an extended warranty, a complete, documented and signed IV Produkt Service and Warranty Manual must be presented.

## 1.12 Dismantling and decommissioning

When an air handling unit is to be dismantled, separate instructions must be followed, see [Dismantling and decommissioning the AHU](#) under Documentation at [ivprodukt.docfactory.com](http://ivprodukt.docfactory.com).

## 1.13 Hygiene configuration (optional extra)

As an optional extra, the unit can be configured in accordance with the Hygiene Standard VDI 6022 Part 1. The unit conforms to guidelines in Hygiene Standard VDI 6022 Part 1. For this to apply, a hygiene inspection of the system must be carried out and the system must be cleaned thoroughly as needed before start-up. The supply air filter must be class ePM1-50% (F7) or have a greater degree of separation.

The following also applies to units without complete integrated control equipment (code MK, US, UC):



### **EXERCISE CAUTION!**

**Pressure surges on filters and air ducts must be prevented through the design of the duct system and the settings/configuration of the control system (e.g. gradual start of fans, open damper when the fans are in operation).**

## Actions in case of standstill

According to guidelines for hygienic design VDI 6022 Part 1:

In case of prolonged standstill in air treatment systems (more than 48 hours), it should be ensured that no moist areas can be found downstream of the cooling coils or humidifier.

In order to avoid the accumulation of moisture – turn off the cooling coils and humidifier in good time and ventilate the air ducts dry (gradual shut-down). Also, be sure to set up or program the required functions in the building's automation/control system for automatic dry blowing of air coolers and downstream sections.

## 2 General

### 2.1 Information messages, not safety-related



Symbol together with information text highlights difficulties and also gives tips and recommendations.

00182

### 2.2 Documentation and support

The documentation for your unit can be found in the Order Portal. See [docs.ivprodukt.com](https://docs.ivprodukt.com) - enter your order number.

It can take up to two weeks for all documentation to be available in the Order Portal. The text "Documentation in progress" appears until the documentation is complete. In case of missing or incorrect documentation, contact DU/Documentation. For other support, please contact the department to which the case relates. See contact details on the last page of the manual.

### 2.3 Spare parts

Spare parts list can be found in the Order Portal. Order spare parts and accessories from IV Produkt. See contact details on the last page of the manual. When contacting a department, state the order number and unit designation as shown on the type plate located on the unit.

## 3 Handling of refrigerant

The following information summarises the requirements and guidelines for handling the refrigerant used in cooling units/reversible heat pumps. For further information, see the F-gas Regulations and the National Refrigerant Handling Regulations.

### 3.1 Responsibility

The physical or legal person (also referred to as ‘operator’) exercising actual responsibility over the technical functioning of the equipment and systems covered by the F-gas Regulation. The operator is usually the owner of the system.

Operator responsibilities:

- Minimise and prevent leakage
- Take corrective action to remedy any leakage that arises
- Ensure that leak inspection, service and repair of the refrigerant circuit are carried out by a certified refrigeration technician
- Ensure that refrigerant is handled in an environmentally safe manner and in accordance with national regulations.

### 3.2 Use and inspection of pressurised equipment

Inspection must be carried out in accordance with the applicable national legislation.

### 3.3 Leakage control and registration



Leakage control must be carried out by a certified refrigeration technician.



Different countries may have different regulations regarding leakage control and record keeping.

Leakage control and record keeping must be carried out in accordance with national applicable regulations.

Refer to the unit’s type plate for refrigerant type, refrigerant quantity, and carbon dioxide equivalent.

All units with refrigerant R410A or R454B are classified as hermetically sealed.

## 4 Technical description

### 4.1 Configuration of the unit

Envistar Top is manufactured as a compact unit or modularly, depending on the size and configuration selected. The compact unit is supplied complete preassembled from the factory. Modular units are supplied in parts to facilitate transport and entry and are assembled on site.

The unit is available in different sizes and in right-hand or left-hand configurations.

The units are equipped with either a counter-flow exchanger or rotary heat exchanger.

As standard, the unit has duct connections at the top. Units with rotary heat exchangers are available as an option with supply and/or extract air connection on the gable. Units with counter-flow exchangers are available as an option with supply and/or exhaust air connection on the gable.

Cooling unit EcoCooler and reversible heat pump ThermoCooler HP are available as optional extras.

### 4.2 Home Concept Configuration

Units with a rotary heat exchanger or counter-flow exchanger in the Home Concept versions have, among other things, specialised control equipment such as automatic defrosting. Units with rotary heat exchangers are also equipped with a pressure balance function for optimal thermal wheel operation.

### 4.3 Detector system, refrigerant

The cooling unit/reversible heat pump with refrigerant R454B is equipped as standard with detectors to detect refrigerant leaks. An exception applies to TEC sizes 06, 09, 10 and TTC size 06, where the detector equipment is available as an optional extra. For units with refrigerant R410A, the detector equipment is available as an optional extra.

To guarantee approved dilution in the event of a refrigerant leak, ensure that the air volumes are greater than the unit's specified minimum air flow, both on the supply air side and extract air side (see [docs.ivprodukt.com](https://docs.ivprodukt.com) - Technical data).

In the event of a refrigerant leak, the installed detector system ensures that the minimum permissible air flow is always achieved, which dilutes the refrigerant to an approved level.

For leak detection and ventilation to work effectively, the unit must have power and the service switch must remain in the 'Auto' position at all times after installation, except during work/servicing.

If the detector triggers a leak alarm, the unit's fans are started to dilute the refrigerant to an approved level, and an alarm notification is shown on the Climatix display.

Should a detector be non-functional, an alarm is triggered and the air handling unit is kept running until the fault is rectified.

In the event of an alarm, correct the fault and then reset the alarm.

If necessary, call a certified refrigeration service with the necessary knowledge of handling and maintaining equipment with refrigerants.

## 4.4 Cooling unit EcoCooler (code TEC-R, TEC-M, TECO, TECX)

The integrated cooling unit with EcoCooler cooling recovery is available as an optional extra to an Envistar Top unit with a rotary heat exchanger or counter-flow exchanger. Cooling recovery means that the heat exchanger starts up when the extract air/room temperature drops below the outdoor temperature and cooling is required.

Cooling units with R454B refrigerant are equipped with integrated control equipment (code MX).

The unit has an electronic expansion valve.

### Compressor

Power control takes place with a speed-controlled compressor. When increased cooling is required, the frequency inverter increases the speed of the compressor.

- TEC-R/TEC-M size 04 has rotary compressor
- TEC-R size 17-22 has piston compressor
- Other units and sizes have a scroll compressor

### Compressor protection

In the event of an alarm initiated by the frequency inverter or the safety circuit, the compressor stops and an alarm indication is given. If the unit is equipped with control equipment, the alarm can be read on the Climatix display.

In the event of an alarm, correct the fault and then reset the alarm. If the safety circuit alarm trips repeatedly, an authorised refrigeration service company must be called in.

#### For size 04-12

The safety circuit consists of a high pressure switch (HP), which protects by tripping when there is high pressure in the system. Use the manual reset button on the pressostat to perform a reset.

#### For size 17-28

The safety circuit consists of a low pressure control and a high pressure switch with a manual reset button. The safety circuit can trip for two different faults:

- High pressure in the system, HP (manual reset on the pressure switch)
- Low pressure in the system, LP (resets itself automatically)

### Function

For integrated control equipment (MX), the cooling unit is interlocked across the ventilation unit. If any of the fans stop, the cooling unit will also stop. The interlock and demand signal is sent via Modbus.

For external control equipment (US, UC, MK), the interlock signal must be sent via a potential-free relay. The demand signal must be sent via 0–10 V.

The cooling unit has internal communication between the frequency inverter and the expansion valve's control equipment. Communication takes place through the Modbus protocol.



## Circuit board

The circuit board in the cooling unit is internally prewired and tested at the factory.

The circuit board contains:

### For size 04

- Compressor inverter

Control centre with integrated expansion valve control unit

### For size 06-12

- Compressor inverter
- Contactor
- Control centre with integrated control unit for expansion valve (for configurations with Carel)

### For size 17-22

- Compressor inverter
- Main switch
- Fuse
- Control unit
- Control unit for expansion valve

### For size 28

- Compressor inverter
- Main switch
- Fuse

Control centre with integrated expansion valve control unit

## Cooling circuit function

A cooling system has four basic components: evaporator, condenser, expansion valve and compressor.

The compressor carries out the work required to run the cooling process. The evaporator is located in the supply air for the unit. The heat from the outdoor air is taken up in this coil, thereby cooling the supply air.

The energy supplied to the cooling system from the evaporator and the compressor leaves the unit via the condenser in the extract air.

It is important to ensure that the air volumes are above the specified minimum flow on both the outdoor air and extract air side. The process cannot work if these air volumes are not available.

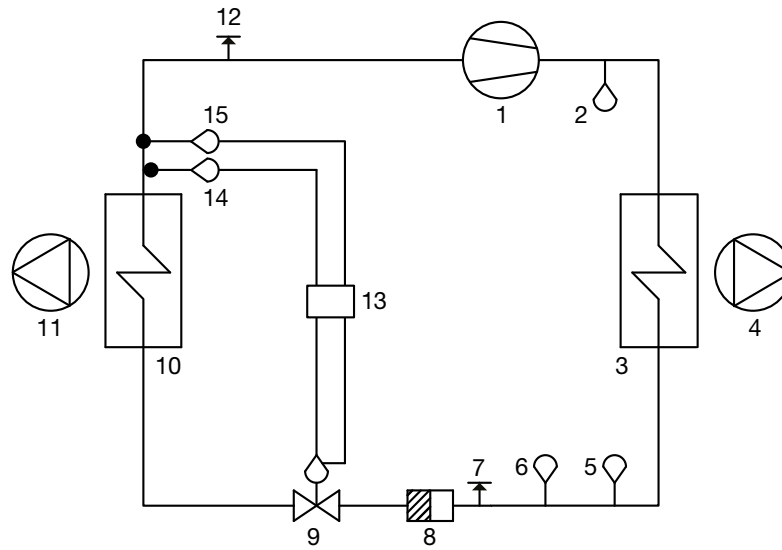

00024

Example of flowchart for refrigerant system size 04-12

- 1 Compressor
- 2 Hot gas sensor
- 3 Condenser
- 4 Extract air fan
- 5 High-pressure switch
- 6 Pressure sensor - high pressure
- 7 Measurement outlet - high pressure
- 8 Drying filter
- 9 Expansion valve
- 10 Evaporator
- 11 Supply air fan
- 12 Measurement outlets - low pressure
- 13 Control unit
- 14 Suction gas sensor (temp after evaporator)
- 15 Pressure sensor - low pressure

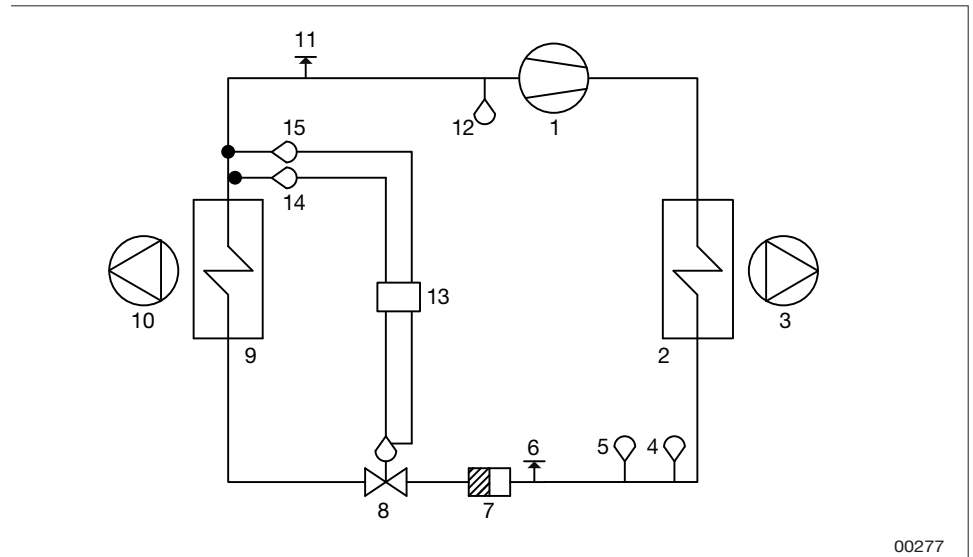

Example of flowchart for refrigerant system size 17-28

- 1 Compressor
- 2 Condenser
- 3 Extract air fan
- 4 Pressure sensor – high pressure (applies to code TECO/TECX size 17/22/28)
- 5 High-pressure switch
- 6 Measuring socket – high pressure
- 7 Drying filter
- 8 Expansion valve
- 9 Evaporator
- 10 Supply air fan
- 11 Measuring socket – low pressure
- 12 Low pressure control
- 13 Control unit
- 14 Suction gas sensor (temp after evaporator)
- 15 Pressure sensor – low pressure

## 4.5 Reversible heat pump ThermoCooler HP (code TTC, TTCH)

The integrated reversible heat pump ThermoCooler HP is available as an optional extra to an Envistar Top unit with a rotary heat exchanger. The units are intended to be used to cool or heat supply air in properties.

Envistar Top with ThermoCooler HP always comes with integrated control equipment (code MX).

The unit has an electronic expansion valve.

### Cooling circuit function

The reversible heat pump has four basic components: evaporator, condenser, expansion valve and compressor.

A 4-way valve is used to shift between cooling and heating.

For cooling, the 4-way valve is in cooling mode. For heating, the 4-way valve is in heating mode. This means that the coil, which was a condenser in cooling mode, becomes an evaporator in heating mode. Conversely, the evaporator becomes a condenser.

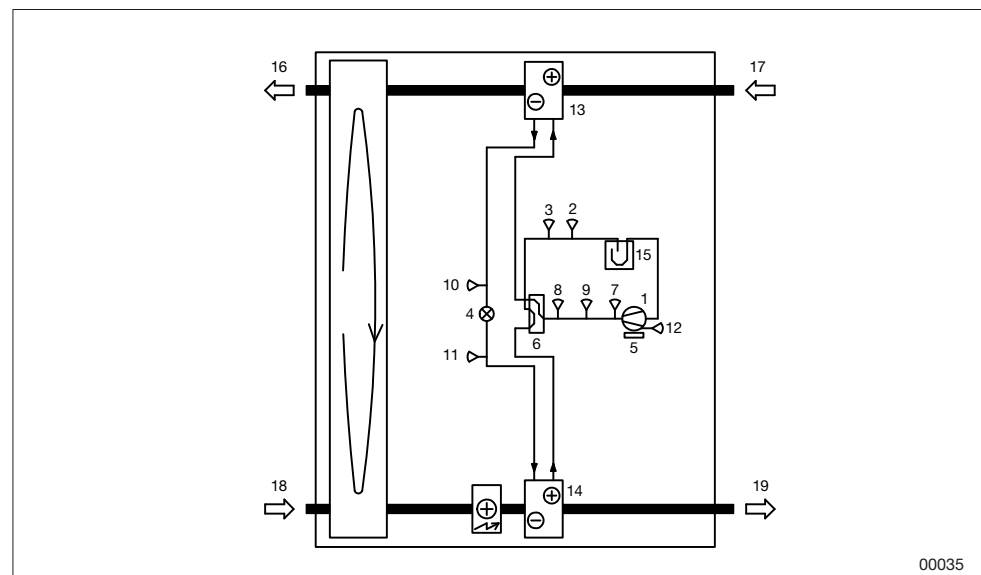

Example of flowchart for cooling mode, reversible heat pump

- 1 Compressor
- 2 Suction gas sensor (temp after evaporator)
- 3 Pressure sensor, low pressure
- 4 Expansion valve
- 5 Frequency inverter
- 6 4-way valve
- 7 High pressure switch
- 8 Pressure sensor, high pressure
- 9 Temperature sensor, hot gas
- 10 Temperature sensor liquid line cooling
- 11 Temperature sensor liquid line heating
- 12 Temperature sensor sump
- 13 Extract air coil (condenser/evaporator)
- 14 Supply air coil (condenser/evaporator)
- 15 Suction gas separator
- 16 Exhaust air
- 17 Extract air
- 18 Outdoor air
- 19 Supply air

## Cooling mode

The compressor carries out the work required to run the cooling process. The evaporator is located in the supply air for the unit. The heat from the outdoor air is taken up in this coil, thereby cooling the supply air.

The energy supplied to the cooling system from the evaporator and the compressor leaves the unit via the condenser in the extract air.

It is important to ensure that the air volumes are above the specified minimum flow on both the outdoor air and extract air side. The process cannot work if these air volumes are not available.

## Heating mode

The heating pump function takes the heat content of the extract air and reuses it, supplying the same heat to the air handling unit's supply air.

The extract air is the heat pump's energy source. When the extract air meets the extract air coil, it is cooled since the coil functions as an evaporator. From the evaporator, the refrigerant moves to the compressor, where it is compressed. The refrigerant then moves to the supply air coil, where the energy from the extract air and the compressor is released. The energy remaining in the extract air downstream of the heat pump is then recovered in the rotor.

These two recovery systems give a very high degree of efficiency. Since the rotor requires less energy to run than the compressor system, this will be in the first instance. The compressor will only start when the rotor's energy recovery is insufficient to heat the supply air.

## Compressor

Power control takes place with a speed-controlled PM scroll compressor. In the event of an increased power requirement, the frequency inverter will increase the speed of the compressor.

## Compressor protection

In the event of an alarm initiated by the control equipment or the safety circuit, the compressor stops and an alarm indication is given. The alarm can be read on the Climatix display or the Carel unit on the unit's circuit board.

In the event of an alarm, correct the fault and then reset the alarm. If alarm trips repeatedly, an authorised refrigeration service company must be called in.

The cooling/heating pump will primarily trip alarms for the following errors:

- High pressure in the system, manual reset on pressure control HP1
- Low pressure in the system
- Alarm from frequency inverter

## Function

The reversible heat pump is interlocked across the ventilation unit. If any of the fans stop, the cooling/heating pump will also stop. The unit will not start unless the minimum flow is achieved. If a trim heater is installed, the minimum flow must also be reached before start up is permitted.

Heating mode is blocked if the return air temperature does not reach the permitted minimum temperature.

The interlock and demand signal is sent via Modbus.



## **Circuit board**

The circuit board for the unit contains:

- Fuses
- Control unit

The circuit board is installed inside the unit and is internally prewired and tested at the factory.

## 5 Commissioning and operation

Commissioning of the unit must be carried out by qualified personnel in accordance with documentation from IV Produkt.

Documents for commissioning:

- Commissioning record (for units supplied with MX control equipment)
- Control diagrams
- Wiring instructions (separate manual for general connection and external fuse)
- Technical data (for power supply, output variant and recommended external fuse)

The documents can be found on [docs.ivprodukt.com](https://docs.ivprodukt.com) - enter your order number.

### 5.1 Prior to commissioning



**WARNING!**

**Risk of serious personal injury and/or damage to air handling unit.**

**Read and understand the entire chapter "1 Security" before working on, servicing, or inspecting the air handling unit.**

Prior to commissioning, the contractor must:

1. Connect the unit to the power supply via a lockable safety switch.
2. Connect the heating/cooling coil, if relevant.
3. Connect the electrical quick-connectors between the unit parts in a modular design.
4. Installation of the pressure sensor and its hoses.
5. Installation and wiring temperature sensor.
6. Connect all ducts.
7. For cooling units/reversible heat pumps with refrigerant R454B – make sure that external dampers communicate with the unit's control equipment so that the air flow through the unit cannot be blocked uncontrollably.
8. For cooling units, the following also applies:



**EXERCISE CAUTION!**

**Risk of compressor damage.**

**The oil in the speed-controlled compressor must be warm before commissioning. The cooling unit must be powered up for at least 8 hours before commissioning.**

Follow the troubleshooting instructions in the troubleshooting chart before contacting a service representative for servicing a unit under warranty. This will prevent any unnecessary service calls.

## 5.2 Starting and stopping the unit

**WARNING!**

Risk of serious personal injury and/or damage to air handling unit.

Read and understand the entire chapter "1 Security" before working on, servicing, or inspecting the air handling unit.



The safety switch is not designed for start-up and/or shut-down of the unit.

During operation: Start and shut down the unit via the service switch in the control equipment.

## 5.3 Before maintenance (switch off the unit)

**WARNING!**

Risk of serious personal injury and/or damage to air handling unit.

Read and understand the entire chapter titled "1 Security" before working on, servicing, or inspecting the air handling unit.



The safety switch is not designed for start-up and/or shut-down of the unit.

The unit must always be switched off before inspection or maintenance begins.

1. Switch off the unit via the service switch in the control equipment.
2. Lock all safety switches in the 0 position. Please note that different parts may have separate safety switches.
3. Before opening covers, wait until all fans have stopped.



## 5.4 Additional wiring instructions

For general connection and fuse protection, see Wiring Instructions (separate manual). For wiring specifications for fans, see Technical data. The documents can be found on [docs.ivprodukt.com](https://docs.ivprodukt.com) - enter your order number.

### Thermal wheel operation (code TXRD, TEXRD) - OJ Electronics

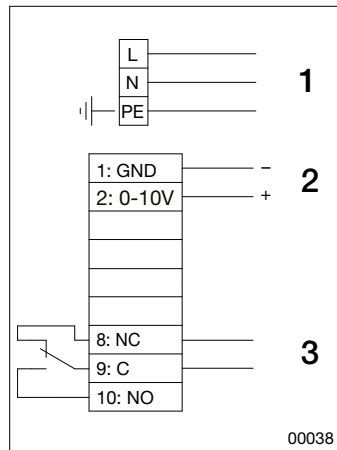

1. Supply 1x230V~50Hz
2. Control
3. Alarm (closed in the event of alarm)

### Air Heater electric (Code ETAB-EV\*, ETKB-EV\*\*)

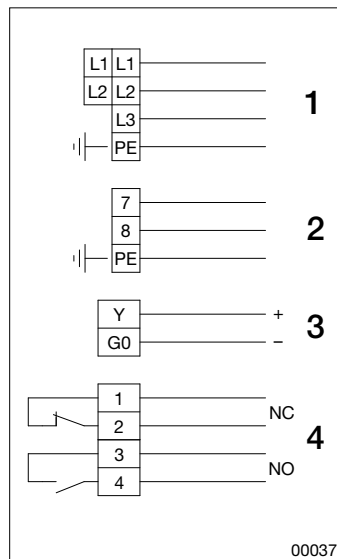

\*For unit mounting, selectable for counter-flow exchanger and rotary heat exchanger.  
 \*\*For duct mounting, selectable for counter-flow exchanger.

1. Supply
2. Control 1x230V ~
3. Control 0-10V =
4. Alarm (closes between 3-4 in the event of alarm)

## 5.5 Operating parameters, cooling

### Cooling unit size 04 (code TEC-R, TEC-M).

#### With control equipment (code MX)

Status information is read on the Climatix display.

Information	Value/example	Explanation
Cooling unit status	Unit ON	Normal status for cooling mode if the compressor is running depends on the cooling load.
	OFFbyALR	Switched off caused by alarm.
	OFFbyDIN	Switched off due to interlock. Climatix interlocks cooling operation.
	OFFbyKey	Switched off due to Carel's ON/OFF menu.
	High cond. temp.	The compressor's speed is limited due to high pressure.
Cooling	%	Cooling load sent from Climatix to Carel.
Frequency inverter output	%	
Compr. no		Compressor number, 1 x compressor (C1)
Compr. Sum alarm		
Alarm management		
*****		
Compressor_C1	Off/On	Compressor operating mode.
Suction gas temp_C1	17°C	Measured suction gas temp.
Evaporating temp_C1	10°C	Calculated evaporation temp based on low pressure.
Low pressure_C1	10 bar	Relative pressure from low pressure sensor.
Overheating_C1	7 K	Measured overheating.
Expansion valve_1	80%	Expansion valve position.

**Cooling unit size 04 (code TEC-R, TEC-M).  
 Without control equipment (code UC, MK or US)**

Status information is read on the Carel display (Main menu/Status - I/O).

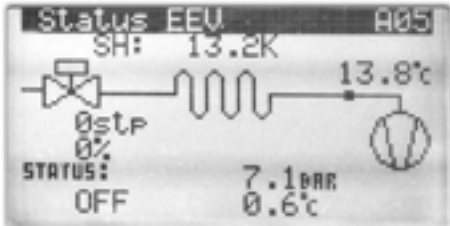
Information	Value/example	Explanation
<b>Status A01</b>		
U6 = Cool.demand:	50%	Cooling load from ventilation control
Remove start delay:	No / Yes	Opportunity to quick start the compressor if Yes is set.
J6 = Modbus Online:	No/Yes	Information about Modbus communication is received.
Modbus command:	Stop/start	Information about command received from Climatix.
Modbus demand:	50%	Information about cooling load received from Climatix.
<b>Status A02</b>		
High Press:	25.00 bar	High pressure
Disch.temp:	50.00°C	Hot gas temperature
Low press:	10.00 bar	Low pressure
Suct.temp:	17.00 °C	Suction gas temperature
<b>Status A03</b>		
U7 = start/stop	Stop	Input for interlock cooling operation
U10 = Alarm reset	No reset	Input to reset alarm
<b>Status A04</b>		
NO6 = General alarm	N/C	Output for sum alarm
<b>Status A05</b>		
		Overheating Suction gas temperature  Valve opening Low pressure Evaporating temperature



Status	A06	Value/example	Explanation
			Cooling load, Output signal, Speed High pressureCondensation temperature Status Hot gas temperature  Suction gas temperature Low pressureEvaporating temperature
<b>Status</b>	<b>A08</b>		
Status		Off/Run/Alarm/Heat	
Current		4.3 Arms	Compressor's power consumption
Voltage		124 Vrms	Power to compressor
Power		0.92 kW	Electrical output used by compressor
DC voltage		391 V	Internal voltage of the inverter
DC ripple		6 V	Variation of internal voltage of the inverter
Drive temp		40.0°C	The inverter's internal temperature
<b>Status</b>	<b>A09</b>		
Working hour			Operating time
Compressor 1		50 h	

**Cooling unit (size 06-12 code TEC-R) /  
 (size 06, 10 code TEC-M).  
 With control equipment (code MX) - without Carel**

Status information is read on the Climatix display.

Information	Value/example	Explanation
<b>Danfoss-VSD</b>		Danfoss Variable Speed Drive
High pressure	25 bar	Relative pressure from high pressure sensor.
Low pressure	10 bar	Relative pressure from low pressure sensor.
Compressor C1	On/Off	Compressor operating mode.
Cooling unit status	Normal	Status of compressor.
Cooling unit alarm	OK/Alarm	The alarm is displayed when the high pressure switch is tripped. In the event of an alarm, see "High pressure switch alarm" page 65.
Alarm	No/Yes	The alarm is displayed if there is a fault with the inverter or compressor. In the event of an alarm, see "Alarm information for inverter and compressor" page 63.
Safety mode	OK	
VSD restr.	No	The inverter restricts the speed.
Cooling	50%	Cooling load from Climatix cooling regulator.
Compr. frequency	60 Hz	Frequency to the compressor.
Hot gas temp	75°C	Hot gas temperature
*****		
<b>Danfoss-VSD-EEV</b>		Electronic Expansion Valve
Suction gas temp	17°C	Measured suction gas temp.
Evaporation temp	10°C	Calculated evaporation temp based on low pressure.
Overheat. ref	7.0 K	Setpoint for overheating. Adjusted automatically.
Overheating	7.0 K	Measured overheating.
Expansion valve	80%	Expansion valve position.
*****		
<b>Danfoss-VSD-MOC</b>		Motor Orientated Control
Inverter temp	80°C	Internal temperature of the inverter.
Supply voltage	230 V	Supply voltage
C1 Output	2.2 Wa	Compressor output
Int. DC voltage	390 V	Internal DC voltage
Motor current phase A	10.0 A	Power consumption phase A
Motor current phase B	10.0 A	Power consumption phase B
Motor current phase C	10.0 A	Power consumption phase C

**Cooling unit (size 06-12 code TEC-R) /  
 (size 06-12 code TEC-M) / (size 17-28 code TECO, TECX).  
 With control equipment (code MX) - with Carel**

Status information is read on the Climatix display.

Information	Value/example	Explanation
Cooling unit status	UnitOn	Normal status for cooling mode if the compressor is running depends on the cooling load.
	OFFbyALR	Switched off caused by alarm.
	OFFbyDIN	Switched off due to interlock. Climatix interlocks cooling operation.
	OFFbyKey	Switched off due to Carel's ON/OFF menu.
	HighcondTmp	Compressor speed lowered due to the high pressure is high.
	FrostProtOpr	Compressor speed lowered to protect the evaporator from freezing. This is not a fault, but a result of extract air flow and return air temperature.
Cooling	50%	Cooling load sent from Climatix to Carel.
Freq. inv. output	x.x%	Shows how much of the full capacity is used by the compressor.
Compr. no	Comp1	No. of compressors
Compr. Sum alarm	Normal	Display of sum alarm.
Danfoss invert. Sa alarm		Sum alarm from the frequency inverter for the compressor.
Alarms	>	Alarm information in the submenu.
*****		
Compressor C1	On/Off	Compressor operating mode.
Suction gas temp C1	17 °C	Measured suction gas temp.
Evaporation temp C1	10 °C	Calculated evaporation temp based on low pressure.
Low pressure C1	10 bar	Relative pressure from low pressure sensor.
Overheating C1	7 K	Measured overheating.
High pressure C1	25 bar	Relative pressure from high pressure sensor.
Expansion valve_1	80%	Expansion valve position
Condensation temp C	42.7°C	Calculated condensation temperature based on high pressure.
Hot gas temperature	75°C	Hot gas temperature
Liquid line T	40°C	Liquid line temperature
Supercooling	2.7°C	Supercooling
Compr. frequency	Hz	Compressor frequency
Overheating ref.	K	Setpoint for overheating. Adjusted automatically.

**Cooling unit (size 06-12 code TEC-R) /  
 (size 06, 10 code TEC-M) / (size 17-28 code TECO, TECX).  
 Without control equipment (code UC, MK, US)**

Status information is read on the Carel display (Main menu/Status - I/O).

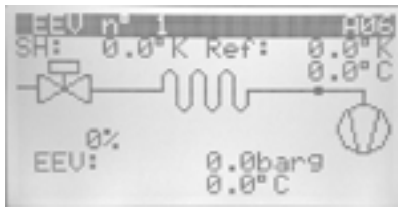
Information	Value/example	Explanation
<b>Status A01</b>		
Compressor:	Off 60.0 Hz	Compressor frequency.
Drive status:	Compressor Off	Status of compressor.
Derating status:	Normal, inactive	Restriction of the maximum frequency due to pressure/temp. ratio.
<b>Status A02</b>		
B1=Cool.demand:	50.0%	The cooling demand signal based on 0–10 V input.
B3=Ambient:	21.7°C	Compressor's ambient temp. (extract air)
High pressure:	25 bar	High pressure (relative)
Discharge:	75°C	Hot gas
<b>Status A03</b>		
Inverter temp:	60°C	Internal temp. of the inverter.
Voltage supply:	230 V	Supply voltage to inverter (1 phase).
Voltage DClink:	390 V	Internal DC voltage of the inverter.
Compressor power:	2200 W	Electrical power use.
Compressor current:	10.0 10.0 10.0 A	Compressor current.
<b>Status A05</b>		
NO1=Compressor:	O	Relay status of operating indication.
NO2=Global alarm:	C	Relay status of alarms.
<b>Status A06</b>		
		Overheating/Setpoint overheating Suction gas temp  Valve opening Low pressure (relative) Evaporation temp
<b>Status A06</b>		
Working hours Comp.1	000000 h	Operating time
<b>Status A11</b>		
Modbus online: Drive application: Drive motor: Expansion valve:	Yes Yes Yes	Status of communication – control application – motor control – expansion valve control
Auto setup:	On	Auto setup for communication, result.
Start auto setup:	Off	Auto setup for communication.



**Cooling unit size 17-22 (code TEC).**  
**With control equipment (code MX)**  
**With Carel expansion valve control PCO5 and EVD**

Status information is read on the Climatix display.

Information	Value/example	Explanation
Cooling unit status	Unit ON	Normal status for cooling mode if the compressor is running depends on the cooling load.
	OFFbyALR	Switched off caused by alarm.
	OFFbyDIN	Switched off due to interlock. Climatix interlocks cooling operation.
	OFFbyKey	Switched off due to Carel's ON/OFF menu.
	High cond. temp.	The compressor's speed is limited due to high pressure.
Cooling	50%	Cooling load sent from Climatix to Carel.
Frequency inverter output	60%	
Compr. no		Compressor number, 1 x compressor (C1)
Compr. Sum alarm		
Alarm management		
*****		
Compressor_C1	Off/On	Compressor operating mode.
Suction gas temp_C1	17°C	Measured suction gas temp.
Evaporating temp_C1	10°C	Calculated evaporation temp based on low pressure.
Overheating_C1	7 K	Measured overheating.
Expansion valve_1	65%	Expansion valve position.



**Cooling unit size 17-22 (code TEC)  
 With control equipment (code MX)  
 With Siemens expansion valve control POL94M**

Status information is read on the Climatix display..

Information	Value/example	Explanation
Regulator	50%	Cooling regulator output signal
Cooling output signal	50%	Cooling need
Cooling unit status	Text	Cooling unit status text
Service switch, cooling	Auto/Off	Setting to block/allow cooling mode
Alarm	-	Shows active alarms
Settings	-	Settings
DX cooling	Off/On	Cooling need
Compressor C1	Off/On	Compressor operating mode.
Frequency inverter output C1	60%	Output signal from frequency inverter
Compr. frequency	Hz	Compressor frequency
Suction gas temp C1	17°C	Measured suction gas temp.
Evaporating temp C1	10°C	Calculated evaporating temp based on low pressure.
MOP	°C	Max. evaporating temperature
Low pressure C1	3.5bar	Measured low pressure
Superheating actual value C1	7K	Measured superheating.
Superheating setpoint C1	7K	Setpoint for superheating.
Expansion valve actual value 1	35%	Expansion valve position.
Expansion valve setpoint 1	35%	Expansion valve setpoint.
High pressure C1	11.2bar	Measured high pressure
Condensation temp C1	45°C	Calculated condensing temperature based on high pressure.
Hot gas temp C1	75°C	Measured hot gas temperature
Liquid line temp C1	40°C	Measured liquid line temperature
Supercooling C1	5K	Calculated supercooling

**Cooling unit size 17-22 (code TEC).**  
**Without control equipment (code UC, MK, US)**

Status information is read on the Carel display (Main menu/Status - I/O).

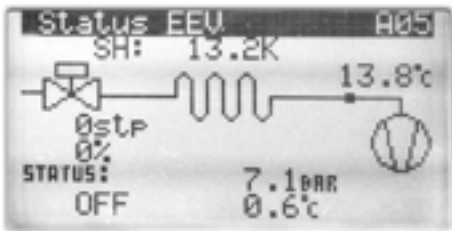
Information	Value/example	Explanation
<b>Status A01</b>		
B1 = Cool.demand:	50%	Cooling load from ventilation control
B2 = Heat demand	0%	Heating requirement
Remove start delay:	NO / YES	Opportunity to quick start the compressor if Yes is set.
<b>Status A03</b>		
ID1= Comp.1 amarm	O	Alarm IN for high pressure switch and frequency inverter
B6 = Remote on/off	O	Interlocking of ventilation control
<b>Status A04</b>		
EVD 1 - DI 1:	O	IN expansion control EVD
EVD 1 - DI 2:	O	IN expansion control EVD
<b>Status A05</b>		
NO1 = Compressor 1	O	OUT for compressor 1
NO2 = Global alarm	C	Alarm OUT for ventilation control
NO3 = 4way valve	C	Not used
<b>Status A06</b>		
Y2= Comp.inverter	0%	OUT signal 0-10V frequency inverter
J8= Modbus activity	NO	Shows whether Modbus is connected
<b>Status A06b</b>		
		<p>Overheating Suction gas temperature</p> <p>Valve opening Low pressure Evaporating temperature</p>
<b>Status A10</b>		
Working hour		Operating time
Compressor 1	50 h	
<b>Status A11</b>		
cCO address	1	Shows connected EVD on terminal J5

**Reversible heat pump (code TTC, TTCH).  
 With control equipment (code MX)**

Status information is read on the Climatix display.

Information	Value/example	Explanation
Cooling unit status	UnitOn	Normal status for cooling mode if the compressor is running depends on the cooling load.
	OFFbyALR	Switched off caused by alarm.
	OFFbyDIN	Switched off due to interlock. Climatix interlocks cooling operation.
	OFFbyKey	Switched off due to Carel's ON/OFF menu.
	HighcondTmp	Compressor speed lowered due to the high pressure is high.
	FrostProtOpr	Compressor speed lowered to protect the evaporator from freezing. This is not a fault, but a result of extract air flow and extract air temperature.
Status HP	Alarms	The heat pump is in alarm mode.
	OffbyKey	Switched off due to Carel's ON/OFF menu.
	Temp ctrl.off	The unit is shut off.
	Cooling mode	The heat pump is in cooling mode.
	Low outdoor temp	The heat pump is blocked as the outdoor temperature is too low.
	Low air flow	The heat pump is blocked as the air flow is too low.
	Low return air temp	The heat pump is blocked as the return air temperature is too low.
	HP Tmp dead	The heat pump does not start due to a small temperature deviation.
	Switch off delay	The heat pump is prevented from switching off due to a short time since start.
	Switch on delay	The heat pump is prevented from starting due to a short time since stop.
	Heating mode	The heat pump is in heating mode.
	No need	No need to run the compressor in the heat pump.
	Heating	0%
Cooling	50%	Cooling load sent from Climatix to Carel.
Freq. inv. output	x.x%	Shows how much of the full capacity is used by the compressor.



Information	Value/example	Explanation
Compr. no	Comp1	No. of compressors
Compr. Sum alarm	Normal	Display of sum alarm.
Danfoss invert. Sa alarm		Sum alarm from the frequency inverter for the compressor.
Alarms	>	Alarm information in the submenu.
*****		
Compressor C1	On/Off	Compressor operating mode.
Suction gas temp C1	17 °C	Measured suction gas temp.
Evaporation temp C1	10 °C	Calculated evaporation temp based on low pressure.
Low pressure C1	10 bar	Relative pressure from low pressure sensor.
Overheating C1	7 K	Measured overheating.
High pressure C1	25 bar	Relative pressure from high pressure sensor.
Expansion valve_1	80%	Expansion valve position
Condensation temp C	42.7°C	Calculated condensation temperature based on high pressure.
Hot gas temperature	75°C	Hot gas temperature
Liquid line T	40°C	Liquid line temperature
Supercooling	2.7°C	Supercooling
Compr. frequency	Hz	Compressor frequency
Overheating ref.	K	Setpoint for overheating. Adjusted automatically.

**Cooling unit (size 06-12 code TEC-R) /  
 (size 06-12 code TEC-M) / (size 17-28 code TECO, TECX).  
 Reversible heat pump (code TTC, TTCH).  
 With control equipment (code MX) - with Carel - with detector system**

Status information is read on the Climatix display.

Information	Value/example	Explanation
Supply air		
Refrigerant leakage	Normal	Leak alarm information
Detector alarm	Normal	Detector alarm information
Concentration LFL	0.0 %	Current measured refrigerant concentration
Temperature chip	22.2 °C	Internal detector temperature
Heater temperature	25.0 °C	Internal detector heater temperature
FW Version	1.0	Detector software version
Sensor ID	54291003	Detector identification number
Extract air		
Refrigerant leakage	Normal	Leak alarm information
Detector alarm	Normal	Detector alarm information
Concentration LFL	0.0 %	Current measured refrigerant concentration
Temperature chip	23.5 °C	Internal detector temperature
Heater temperature	25.0 °C	Internal detector heater temperature
FW Version	1.0	Detector software version
Sensor ID	54291211	Detector identification number
Calibrate detector		Function to calibrate or test the detector
Calibration status supply air	OK	Calibration information
Calibration status extract air	OK	Calibration information

## 6 Maintenance instructions

### 6.1 Service schedule

The service schedule comprises actions and service intervals for functional sections that can be part of the air handling unit. For current parts, refer to [docs.ivprodukt.com](https://docs.ivprodukt.com) (Technical data).

Make copies of the service schedule for future use before you fill in servicing data for the first time.

For hygiene inspections according to guideline VDI 6022, see separate [VDI 6022 Checklist for Operation and Maintenance, Hygiene checks](https://ivprodukt.docfactory.com) at [ivprodukt.docfactory.com](https://ivprodukt.docfactory.com).

Service year 20 .....		Order no. ....		Project name .....				
Comments .....				Service performed * (date and signature)				
Functional section	Code	Recommended action (insp.)	Page ref.	12 mths	24 mths	36 mths	48 mths	
 Filter supply air, extract air	ETFL	Check pressure drop Change filter if necessary	36	signature	signature	signature	signature	
 Rotary heat exchanger	TXRR	Visual inspection Check press. balance Check diff. pressure Control rotor speed Clean if necessary	39	signature	signature	signature	signature	
 Counter-flow exchanger	TXMM	Visual inspection Clean if necessary Check function	44	signature	signature	signature	signature	
 Air heater water	ETAB-VV ETAB-TV SKB-VV	Visual inspection Clean if necessary Check function	46	signature	signature	signature	signature	
 Air heater electric	ETAB-EV ETKB-EV ETAB-SV	Visual inspection Clean if necessary Check function	48	signature	signature	signature	signature	
 Air cooler water/DX	ETKB-VK SKB-VK	Visual inspection Check drainage Clean if necessary Check function	50	signature	signature	signature	signature	
 Fan unit	ELFF	Visual inspection Clean if necessary Check the air flow	52	signature	signature	signature	signature	
 Damper	ETSP-UM ETSP-TP	Visual inspection Clean if necessary Check tightness	56	signature	signature	signature	signature	
 Sound attenuator	ETLD	Visual inspection Clean if necessary	58	signature	signature	signature	signature	

*\*More frequent servicing may be required in certain environments. Replace the filter if the pressure drop across the filter exceeds the specified final pressure drop.*

**Cooling unit (code TEC-R / TEC-M / TECO / TECX)**

Service year 20 .....		Order no.....		Project name .....			
Comments .....				Service performed * (date and signature)			
Functional section	Code	Recommended action (insp.)	Page ref.	12 mths	24 mths	36 mths	48 mths
 Cooling unit	TEC-R TEC-M TECO TECX	Visual inspection Check drainage. Clean if necessary Check function Check for leakage and report if necessary	59	signature	signature	signature	signature

*\*More frequent servicing may be required in certain environments.*

**Reversible heat pump (code TTC / TTCH)**

Service year 20 .....		Order no.....		Project name .....			
Comments .....				Service performed * (date and signature)			
Functional section	Code	Recommended action (insp.)	Page ref.	12 mths	24 mths	36 mths	48 mths
 Reversible heat pump	TTC TTCH	Visual inspection Check drainage. Clean if necessary Check function Check for leakage and report if necessary	59	signature	signature	signature	signature

*\*More frequent servicing may be required in certain environments.*

## 6.2 Filters (code ELEF)

The air filters in an air handling unit are designed to prevent dust and other impurities from entering the building. They should also protect sensitive components inside the unit, e.g. water coils and heat exchangers, from exposure to impurities.

The dust separation efficiency varies considerably between various filter types. The dust collecting efficiency also varies substantially. It is therefore important to use filters of the same quality and capacity when you change them.

The filters are designed for one-time use. If they become fouled, the unit will lose capacity. The filters should therefore be changed if the pressure drop across them exceeds the specified final pressure drop.

It is important to stop the unit before changing filters to prevent dust from coming loose and being drawn into the unit. The inside surfaces of the filter sections should therefore also be cleaned when the filters are changed.

### Lifespan and filter control Carbon filter

The function and lifespan of the carbon filters depends on the volume of air that passes through and on the molecular density of odorous substances. This means that the time intervals for filter replacement can vary from unit to unit depending on operation mode and the volume of odorous substances in the air.

Units delivered with control equipment (code MX) are equipped with the filter control function – FLC (Filter Lifetime Control). FLC indicates when it is time to replace the carbon filter. Indication is through an alarm on the Climatix display.

FLC calculates the volume of air passing through the carbon filters and triggers the alarm for filter replacement when the preset value has been reached. The value for air passing through is specified in mega cubic metres ( $Mm^3$ ). The function does not take into account the odour content of the air, which means that the indication should be regarded as a recommendation for checking the filter function. If no odours pass through, there is no need to replace the filter.

Preset FLC values are based on max. air flow over 12 months of full-time operation. If required, the value can be lowered in order to: - change to more frequent filter replacement intervals for max. air flow - retain the filter replacement interval of 12 months for lower air flows.

To change the value, refer separate Climatix control documentation.



## Inspection



**WARNING!**  
 Risk of serious personal injury and/or damage to air handling unit.  
 Read and understand the entire chapter "1 Security" before working on, servicing, or inspecting the air handling unit.

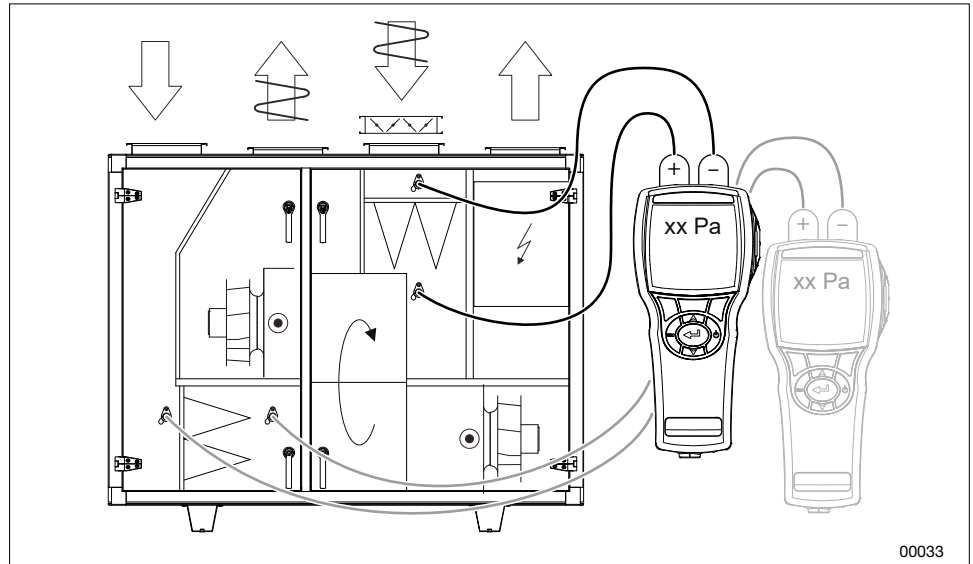

00033

Check the pressure drops across the filters. Pressure drop is measured with a pressure gauge connected to measurement outlets. The measurement outlets are connected to each side of the filter.

If the filter has reached its specified final pressure drop, it should be changed. The final pressure drop is specified on the filter section decal (filled in when the air handling unit is put into operation).

### FILTERDATA

Nominellt luftflöde  m<sup>3</sup>/s  
 Nominal air flow.....  m<sup>3</sup>/h  
 Antal filter                      Mått  
 Number of filters..... Dimensions.....  
 .....  
 Filterklass/Filter Class.....  
 Begynnelsestryckfall  
 Initial Pressure Drop.....Pa  
 Sluttryckfall  
 Final Pressure Drop.....Pa

Art. Nr: 19121-1101\_02SV

## Filter data

Current filters can be found in the Technical Data and Spare Parts List under Order Unique Documentation at [docs.ivprodukt.com](https://docs.ivprodukt.com).

## Filter replacement

**WARNING!**

Risk of serious personal injury and/or damage to air handling unit.

Read and understand the entire chapter "1 Security" before working on, servicing, or inspecting the air handling unit.

1. Switch off the unit, see "5.3 Before maintenance (switch off the unit)" page 20.
2. Wait until the fans have stopped, then open the inspection door.
3. Release the eccentric rails.
4. Remove the old filter by pulling it towards you. Discarded filters should be disposed of correctly. The carbon filters are combustible in their entirety.
5. Clean the filter cabinets.
6. Install the new filter, press in the eccentric rails to engage them and close the inspection door.
7. Reset the FLC filter control function via the Climatix display, refer to separate Climatix control documentation. (Only applicable to the Home Concept configuration of the unit equipped with carbon filter and integrated control equipment (code MX).
8. Start the unit.

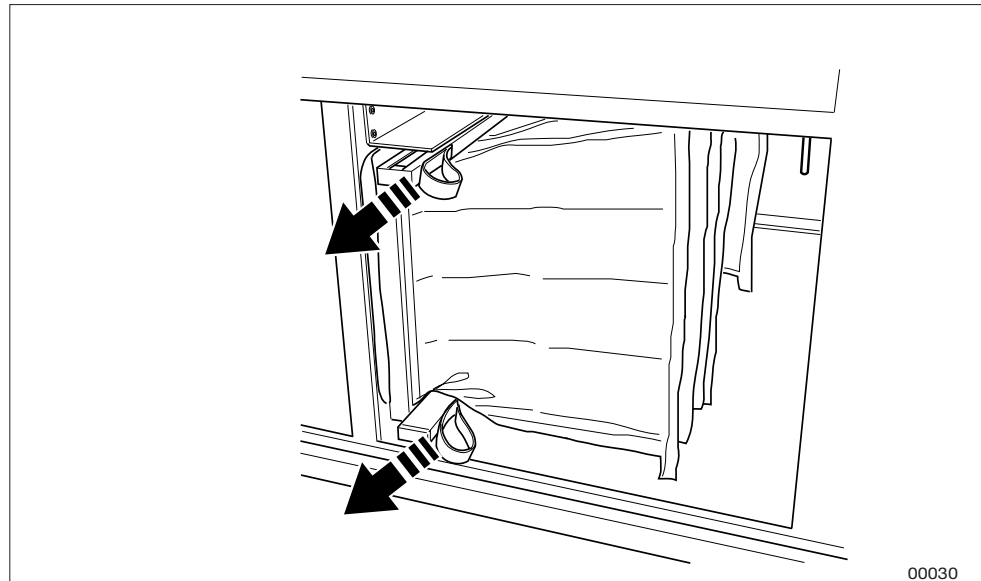

*Example eccentric rails*

## 6.3 Rotary heat exchanger (code TXRR)

The purpose of the recovery unit is to recover heat from the extract air and transfer this heat to the supply air in order to minimise energy use.

Faults in recovery unit functionality result in reduced heat recovery efficiency and increased energy use and means that the design supply air temperature cannot be obtained when the outdoor temperature is low

A conceivable reason for reduced recovery efficiency may be that the rotor rotates too slowly because the drive belt is slipping. The rotor speed should not be lower than 8 rpm during full energy recovery.

It is not usual for the rotor passages to become fouled with dust, since the rotor is normally self-cleaning. However, this might occur if the dust is of a sticky nature.

A reduction of the extract air flow, e.g. due to fouling of the extract air filter, entails reduced heat recovery efficiency.

### Home Concept Configuration

Units in the Home Concept design are equipped with a function to control the pressure balance of the thermal wheel to ensure the correct leakage function and purging function. For units supplied with control equipment, the function is connected and activated at the factory. For units without control equipment, this function must be connected to the unit.

### Inspection



**WARNING!**  
**Risk of serious personal injury and/or damage to air handling unit.**  
**Read and understand the entire chapter "1 Security" before working on, servicing, or inspecting the air handling unit.**

1. Switch off the unit, see "5.3 Before maintenance (switch off the unit)" page 20.
2. Wait until the fans have stopped, then open the inspection door.
3. Check that the rotor rotates easily. If it is sluggish, you might have to adjust the bristled sealing strip.
4. Check that the rotor's bristled sealing strip seals against the side plates and that it is not worn. The bristled sealing strip is subject to wear and can be adjusted or replaced if the need arises.
5. Check that the drive belt is properly tensioned and does not slip. If it slips, it will have to be shortened. The rotor speed should not be lower than 8 rpm during full energy recovery.
6. Check that the drive belt is intact and clean.

7. Check that the rotor's inlet surfaces are not covered with dust or other impurities. NB: Avoid touching the rotor inlet and outlet surfaces with your hands or tools.
8. Check the pressure balance:

For design Home Concept, the trim damper ETSP-UM/TR regulates the pressure balance automatically against the set value in the controller unit. Check that the measured pressure balance between measurement tappings P2 and P3 corresponds to the set pressure balance setpoint in the controller unit (-10 Pa).

Example:

Measurement outlets for P2: Downstream supply air fan (SF) generates negative pressure in relation to the atmospheric pressure (atm), e.g. -100 Pa

Measurement outlets for P3: Downstream extract air fan (EF) and trim damper generate greater negative pressure than at P2, e.g. -110 Pa.

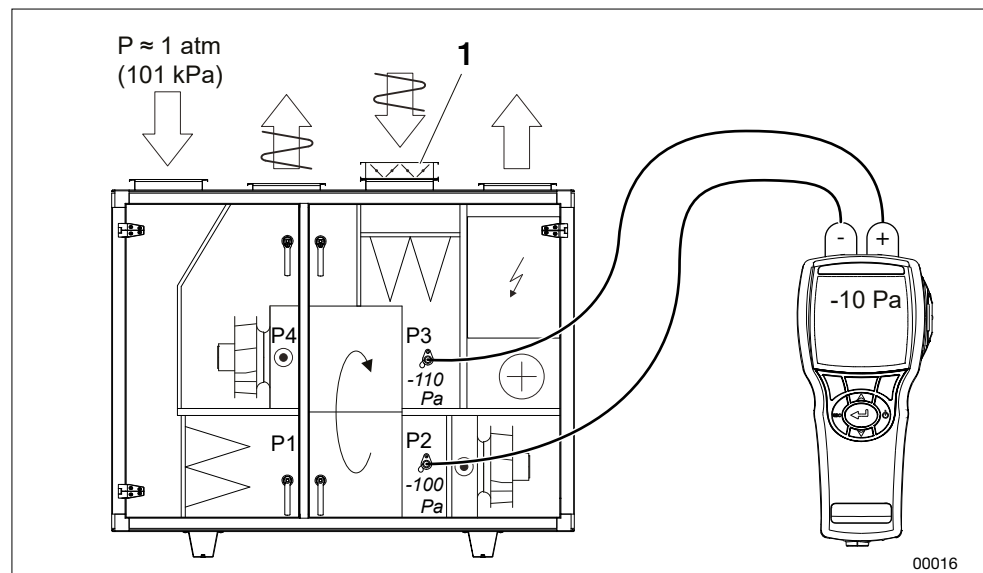

Measurement tapping for pressure balance - units in the Home Concept design

1. Trim damper

For units (code TER/TXR), the pressure balance must be ensured by checking that the under pressure P3 is greater than the pressure P2 (min. diff 25 Pa). Otherwise an ETSP-TR trim damper can be used on the extract air side in order to throttle in the correct pressure balance.

Example:

Measurement outlets for P2: Downstream supply air fan (SF) generates negative pressure in relation to the atmospheric pressure (atm), e.g. -100 Pa

Measurement outlets for P3: Downstream extract air fan (EF) and any trim damper generate greater negative pressure than at P2, e.g. -125 Pa.

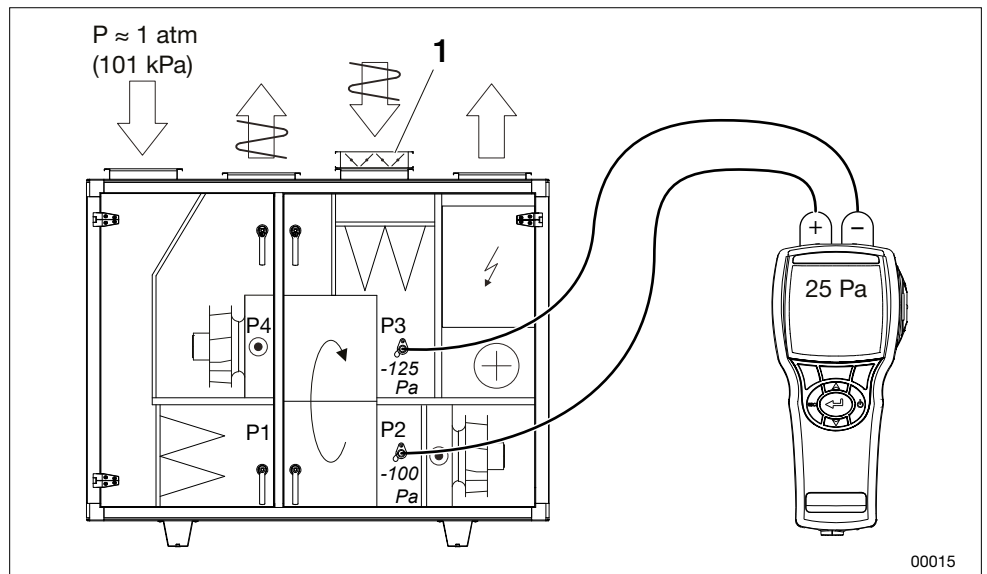

Measurement outlets for pressure balance – unit with control equipment (code MX)

1. Trim damper

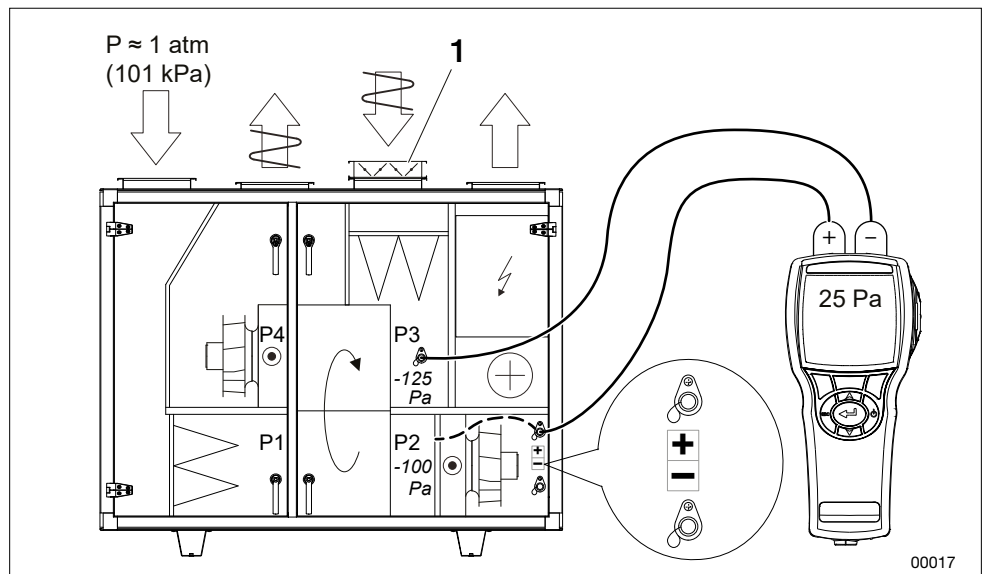

Measurement outlets for pressure balance – unit without control equipment (code UC, MK, US)

1. Trim damper

9. Check the differential pressure across the rotor. The purging sector is factory-installed, set to the maximum open position. Depending on the unit's pressure difference across the rotor, the purging sector may need adjustment. An incorrect setting may impair the efficiency. Inspection and adjustment should be carried out as follows:

- Measure and write down the differential pressure between the outdoor air (P1) and the extract air (P3).

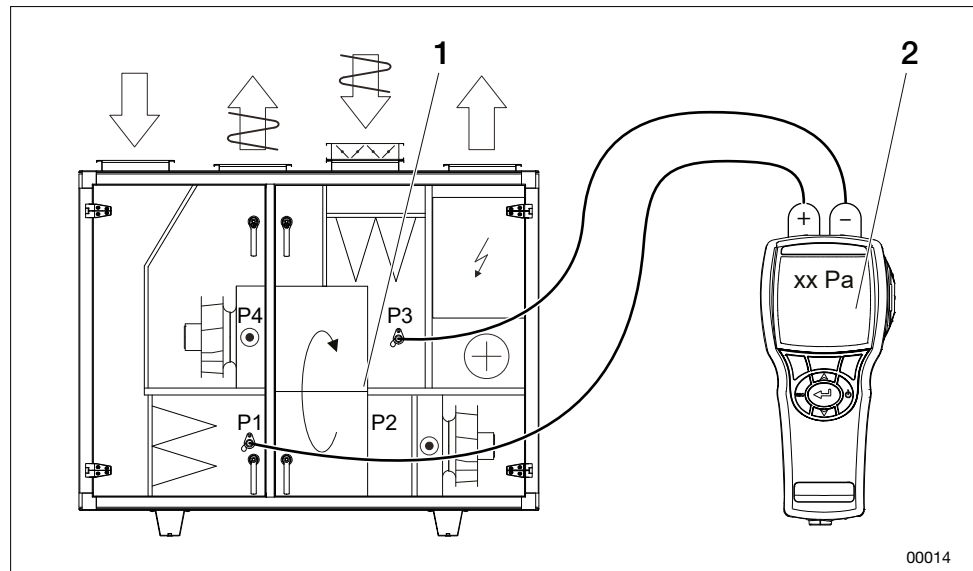

1. Purging sector
2. Pa, see table below

- Read the recommended setting (adjustment hole in the purging sector) from the table below.

	Rotor variant	Adjustment hole in the purging sector		
		3 open*	2 intermediate position	1 closed
Diff. pressure between P1 and P3 (Pa)	R20, R30, R40, NO, NE	< 300	> 300	-
	R50, R60, NP, NX	< 400	> 400	-

\*maximum open purging sector, preset mode from the factory

- Adjust the purging sector if the need arises. The illustration shows the purging sector set to the maximum open position.

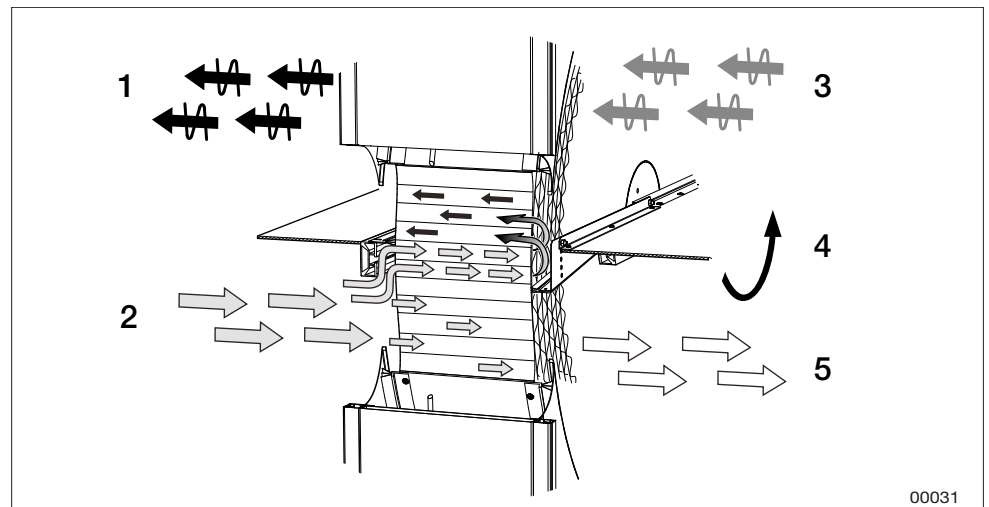

Schematic diagram - sizes and model may vary.

1. Exhaust air
2. Outdoor air
3. Extract air
4. Direction of rotation
5. Supply air

## Cleaning



### WARNING!

**Risk of serious personal injury and/or damage to air handling unit.**

**Read and understand the entire chapter "1 Security" before working on, servicing, or inspecting the air handling unit.**

- Remove dust by carefully vacuum cleaning using a soft brush.
- In the event of stubborn and heavy-duty dirt, the rotor can be sprayed with a mild, alkaline detergent.
- Compressed air at low pressure (max. 6 bar) can be used for blowing the surfaces clean. To avoid damage, the nozzle should not be held any closer to the rotor than 5–10 mm.

A hygroscopic rotor variant can absorb particles which in some cases give off odours. In case of odour problems, it is recommended to fully open purging sector and rotor speed 8 rpm in normal operation. To prevent odours arising, exercise run the hygroscopic rotor using the integrated control function. If an odour persists, we recommend cleaning the thermal wheel with a mild, alkaline detergent.

When cleaning, allow one of the fans to suck the cleaning agent into the rotary heat exchanger. Post-rinsing is not normally required.

## Lubrication

The bearings and drive motor are permanently lubricated and do not require additional lubrication.

## 6.4 Counter-flow exchanger (code TXMM)

The purpose of the counter-flow exchanger is to recover heat from the extract air and transfer this heat to the supply air in order to minimise energy use.

Faults in counter-flow exchanger functionality reduce recovery efficiency and increase energy consumption. The projected supply air temperature will not be reached when outdoor temperatures are low.

Possible reasons for reduced recovery efficiency could be the fouling of the heat-exchanging surfaces (fins) or that the bypass damper is not closing completely.

A reduction of the extract air flow, e.g. due to fouling of the extract air filter, entails reduced heat recovery efficiency.

### Inspection

	<p><b>WARNING!</b>  <b>Risk of serious personal injury and/or damage to air handling unit.</b>  <b>Read and understand the entire chapter "1 Security" before working on, servicing, or inspecting the air handling unit.</b></p>
---	---

1. Switch off the unit, see "5.3 Before maintenance (switch off the unit)" page 20.
2. Wait until the fans have stopped, then open the inspection door.
3. Inspect the fins for fouling.
4. Perform a visual inspection of the automatic defrosting dampers and damper motors.
5. Check that the bypass damper is tightly shut when defrosting is not taking place.
6. Check the functionality of the drain and water trap. A water trap without a non-return valve should be filled with water.

### Cleaning

	<p><b>WARNING!</b>  <b>Risk of serious personal injury and/or damage to air handling unit.</b>  <b>Read and understand the entire chapter "1 Security" before working on, servicing, or inspecting the air handling unit.</b></p>
---	---

The counter-flow exchangers are designed to prevent dirt and deposits from coming into contact with the heat transfer surfaces. Most of the particles in the air will pass through the counter-flow exchanger. The main risk for fouling of the counter-flow exchanger comes from slow-moving substances that condense on the surfaces, and also from fibres from tumble dryers, for instance.

The recommended way to clean the counter-flow exchanger is by flushing with hot water, if necessary adding some mild detergent. The counter-flow exchanger is equipped with a drip tray that is used for collecting the water used for flushing. Inspect the waste outlet and water trap before flushing.



**BE CAREFUL!**

**High pressure flushing must not be directed at the fins.  
Be careful in order to ensure that the fins do not become  
deformed or break.**

At operating temperatures below 0°C, the counter-flow exchanger must be dry before commissioning.

### **Functional description, defrost and bypass function (ODS) (code TXMM-XP/NP/XB)**

Under certain operating conditions, frost and ice may form on the extract air side of the counter-flow exchanger. In order to optimise heat recovery, there is a built-in defrost function. This is based on the principle that the defrost function is engaged when the pressure drop over the extract air side of the counter-flow exchange exceeds a certain value.

Defrosting takes place through the regulation of dampers on the outdoor air side of the counter-flow exchanger. The dampers have separate damper motors that are controlled by a defrost program. Damper control means that there are a number of different combinations of damper positions, for instance that one of the dampers can be partly open while another is closed and the third damper is fully open.

During full heat recovery and when the unit is switched off, the dampers should be fully open (bypass damper closed). When there is a risk of frost, the dampers can be in different positions.

The defrost and bypass function is preset at the factory and any adjustments must be performed by IV Produkt.

### **Functional description, frosting function (BYP) (code TXMM-NP)**

Under certain operating conditions, frost and ice may build-up on the extract air side of the heat exchanger. In order to optimise heat recovery, and avoid freezing, there is a built-in frosting function. The principle is based on the frosting function starting when the temperature of the exhaust air side's coldest surface falls below a certain value.

The freezing process is prevented by reducing heat recovery gradually through regulating dampers on the heat exchanger's exhaust air side. The heat recovery damper closes and the bypass damper opens. In this way, the exhaust air temperature is increased and freezing is avoided.

During full heat recovery and when the unit is switched off, the dampers should be fully open (bypass damper closed).

The frosting and bypass functions are preset at the factory and any adjustments may only be performed by IV Produkt.

## 6.5 Air heater water (code ETAB-VV, SKB-VV) and Thermoguard (code ETAB-TV)

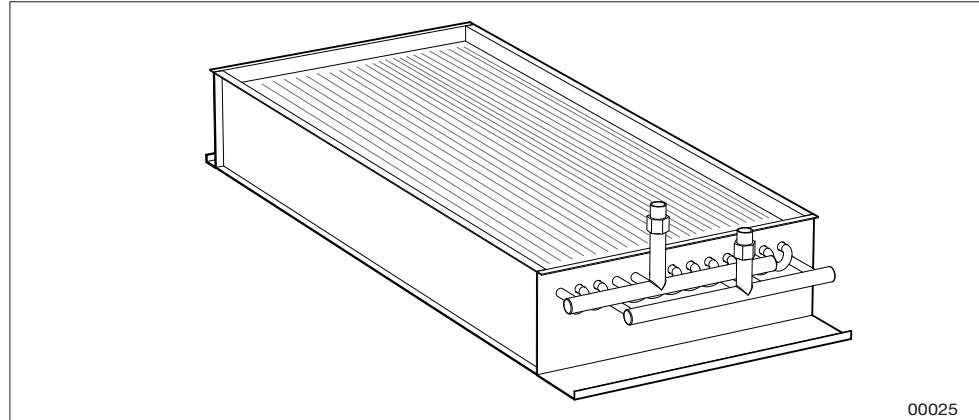

*Air heater water (ETAB-VV)*

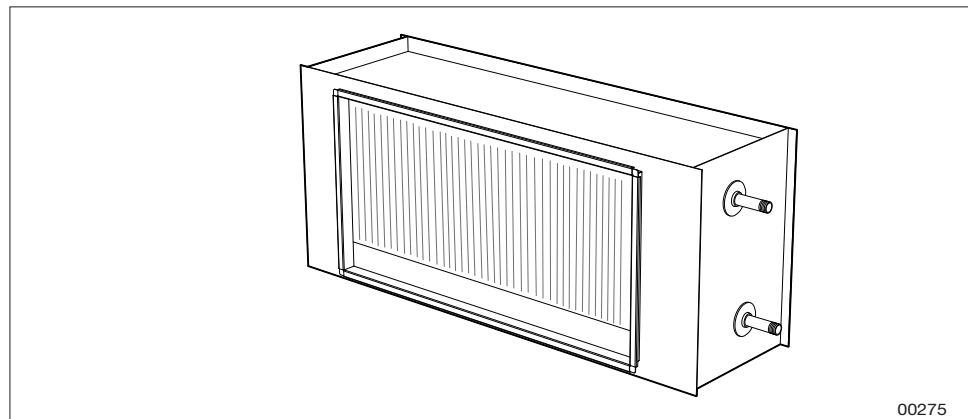

*Air heater water duct (SKB-VV)*

The heating coil consists of a number of copper tubes with aluminium fins pressed on them. The coil will have impaired capacity if dust forms a coating on the coil surfaces.

Not only does this impair the heat transfer capacity of the coil, it also increases the pressure drop on the air side. Even if the ventilation system is fitted with high quality filters, as time passes dust deposits will form on the front edges of the coil fins (at the inlet side). To utilise its full capacity, the coil must be well vented. The pipework should be vented by opening the bleeder screws in pipe connections and/or an air vessel.

### Inspection

	<p><b>WARNING!</b>  <b>Risk of serious personal injury and/or damage to air handling unit.</b>  <b>Read and understand the entire chapter "1 Security" before working on, servicing, or inspecting the air handling unit.</b></p>
---	---

Check:

- The coil fins to detect possible mechanical deformity.
- That the water coil is not leaking.

## Cleaning



**WARNING!**  
 Risk of serious personal injury and/or damage to air handling unit.  
 Read and understand the entire chapter "1 Security" before working on, servicing, or inspecting the air handling unit.

If the fins on the coil are dirty, vacuum clean from the inlet side. Alternatively, you can blow them clean with compressed air from the outlet side. In the event of stubborn dirt, use a mild, alkaline detergent.

## Venting



**WARNING!**  
 Risk of serious personal injury and/or damage to air handling unit.  
 Read and understand the entire chapter "1 Security" before working on, servicing, or inspecting the air handling unit.

Bleed the heating coil and the pipework if needed. Bleeder screws are on top of the coil or on the tube connections.

## Function

Check that the coil is radiating heat. This can be done by temporarily increasing the temperature setting (setpoint).

## Additional maintenance for ThermoGuard



**WARNING!**  
 Risk of serious personal injury and/or damage to air handling unit.  
 Read and understand the entire chapter "1 Security" before working on, servicing, or inspecting the air handling unit.



**EXERCISE CAUTION!**  
 To ensure correct ThermoGuard coil function, the entire coil must be allowed to thaw before returning it to full operation. Make sure that water is circulating in the entire coil when you start it up.

- The ThermoGuard coil must be fitted with a safety valve, the function of which should be checked regularly (at least once a year). If you see that the valve is leaking, this is normally due to impurities from the pipe system that have accumulated on the valve seat. In normal cases, it is sufficient to carefully turn the valve knob and in this way "flush" the valve seat clean. If the safety valve continues to leak, you will have to replace it with a new one of the same type and with the same opening pressure.
- Any shut-off valves on the supply or return lines may not be closed if freezing temperatures are likely.
- If a ThermoGuard coil has frozen, let it thaw completely before restarting operation. If the heat recovery unit is installed upstream of the coil, it is often sufficient to run heat recovery to thaw the coil. If this does not work, some other external heating source must be used for thawing the water coil.

## 6.6 Air Heater electric (Code ETAB-EV, ETKB-EV, ETAB-SV)

- ETAB-EV for unit assembly
- ETAB-SV for unit assembly reversible heat pump
- ETKB-EV for duct mounting

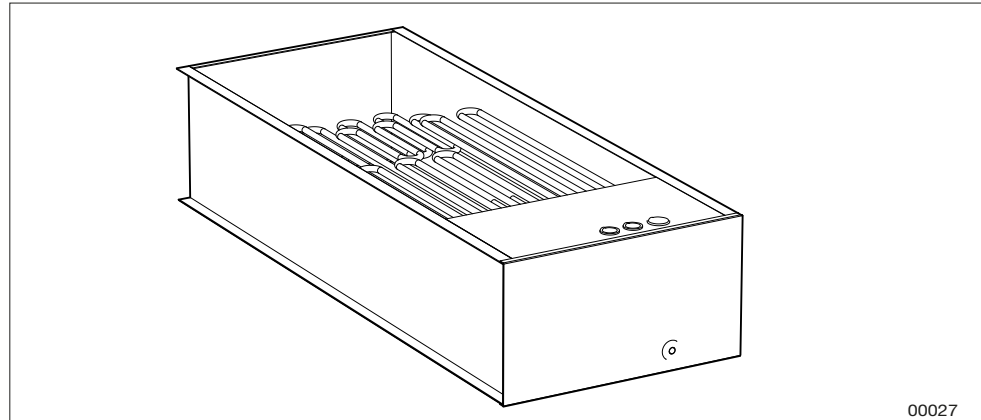

*Air heater electric (ETAB-EV, ETAB-SV)*

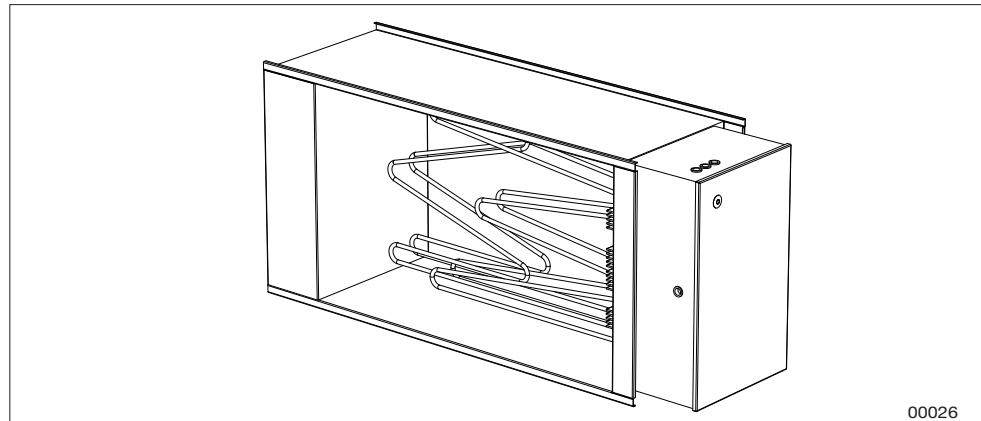

*Air heater electric size 04-12 (ETKB-EV)*

The electric heater consists of encapsulated stainless steel smooth pipe elements. Heavy soiling on the heating elements may cause the temperature to get too hot. This can shorten their service life. This might also entail an odour of burnt dust and, in the worse case, the risk of fire. Overheated elements may become deformed or loosen from their suspended brackets and heat the air unevenly.

### Inspection

	<p><b>WARNING!</b>  <b>Risk of serious personal injury and/or damage to air handling unit.</b>  <b>Read and understand the entire chapter "1 Security" before working on, servicing, or inspecting the air handling unit.</b></p>
---	---

Check that the elements are correctly positioned and that they are not deformed in any way.

## Cleaning



**WARNING!**  
 Risk of serious personal injury and/or damage to air handling unit.  
 Read and understand the entire chapter "1 Security" before working on, servicing, or inspecting the air handling unit.

Vacuum and/or wipe all surfaces with a cloth.

## Function



**WARNING!**  
 Risk of serious personal injury and/or damage to air handling unit.  
 Read and understand the entire chapter "1 Security" before working on, servicing, or inspecting the air handling unit.

1. Simulate reduced required output by temporarily lowering the temperature setting (setpoint), so that all the electric output steps (contactors) switch out.
2. Then sharply increase the setpoint setting and check that the electrical steps switch in.
3. Restore the temperature setting.
4. Stop the unit. NB: Do not stop operation with the safety switch! All the electric output steps should switch out (i.e. the contactors in the OFF position). Stopping the unit may be delayed a few minutes to allow the fans to cool the heat energy stored in the air heater.

The electric heater is equipped with dual temperature limiters. The one that resets itself automatically should be set to 70°C.

The overheat protection with manual reset interrupts operation when the heater reaches approx. 120°C and is located on the cover panel on the side of the heater. **Determine the cause of overheating and take corrective action before you reset the protection device.**

NB: The risk of overheating increases as the air flow through the unit decreases. The air speed should not be lower than 1.5 m/s.

## 6.7 Air cooler water (code ETKB-VK, SBK-VK)

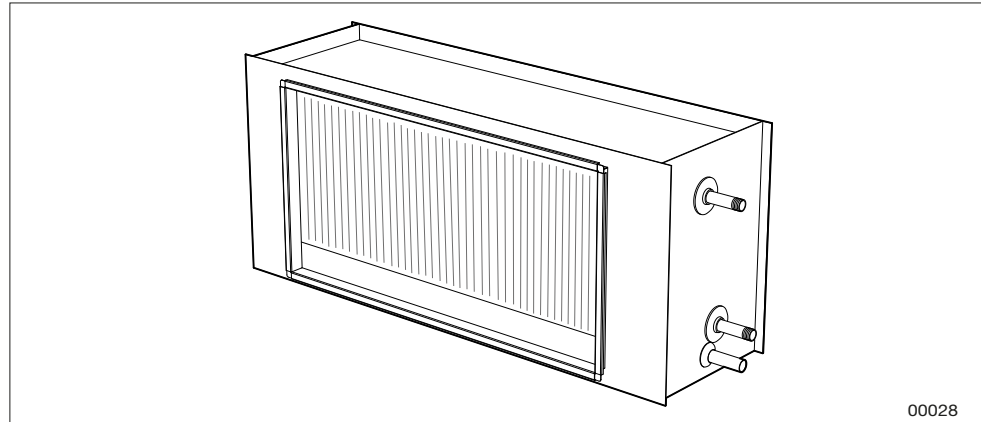

*Air cooler water (code ETKB-VK)*

The cooling coil consists of a number of copper tubes with aluminium fins pressed onto them. The coil will have impaired capacity if dust forms a coating on the coil surfaces.

Not only does this impair the heat transfer capacity of the coil, it also increases the pressure drop on the air side.

Even if the ventilation system is fitted with high quality filters, as time passes dust deposits will form on the front edges of the coil fins (at the inlet side). A drip tray with drain is located under the cooling coil for collecting and removing evaporation water.

### Inspection

	<p><b>WARNING!</b> Risk of serious personal injury and/or damage to air handling unit. Read and understand the entire chapter "1 Security" before working on, servicing, or inspecting the air handling unit.</p>
---	---

Check:

- The coil fins to detect possible mechanical deformity.
- That the water coil is not leaking.
- That cooling energy is uniformly distributed across the coil surfaces (in operation).
- The drip tray and drain with water trap (clean if necessary).
- That the water trap (without non-return valve) is filled with water.

## Cleaning



**WARNING!**

**Risk of serious personal injury and/or damage to air handling unit.**

**Read and understand the entire chapter "1 Security" before working on, servicing, or inspecting the air handling unit.**

If the fins on the coil are dirty, vacuum clean from the inlet side. Alternatively, you can blow them clean with compressed air from the outlet side. In the event of stubborn dirt, use a mild, alkaline detergent.

For more information, refer to [Cooling coil, cleaning](#) under Documentation at [ivprodukt.docfactory.com](http://ivprodukt.docfactory.com).

## Venting



**WARNING!**

**Risk of serious personal injury and/or damage to air handling unit.**

**Read and understand the entire chapter "1 Security" before working on, servicing, or inspecting the air handling unit.**

Bleed the cooling coil and the pipe connections if needed. Bleeder screws are on top of the coil or on the tube connections.

## Function



**WARNING!**

**Risk of serious personal injury and/or damage to air handling unit.**

**Read and understand the entire chapter "1 Security" before working on, servicing, or inspecting the air handling unit.**

Check that the coil is emitting cooling energy. This can be done by temporarily lowering the temperature setting (setpoint). Cooling is blocked when the outdoor temperature drops below the set value for cooling start.

## 6.8 Fan unit (code ELFF)

The purpose of the fans is to transport air through the system, i.e. the fan must overcome the flow resistance in air terminals, air ducts and the unit.

The fan speed is regulated to provide correct air flow. If the fans generate a lower air flow, this will impair the function of the ventilation system.

- If the supply air flow is too low, the system will be out of balance, causing poor room climate.
- If the extract air flow is too low, the ventilation capacity will be unsatisfactory. Imbalance may also force moist air out into the building structure. One reason why the fans are generating too little air flow may be that impurities have collected on the fan impeller blades.

### Inspection

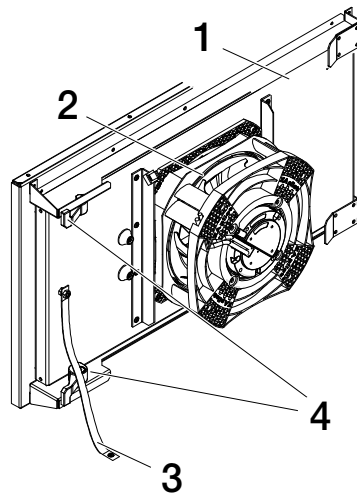

*Example fan unit size 04 with fan impeller 020*

- 1. Fan mounting on sheet metal*
- 2. Fan impeller with motor*
- 3. Earthing braid*
- 4. Snap lock*



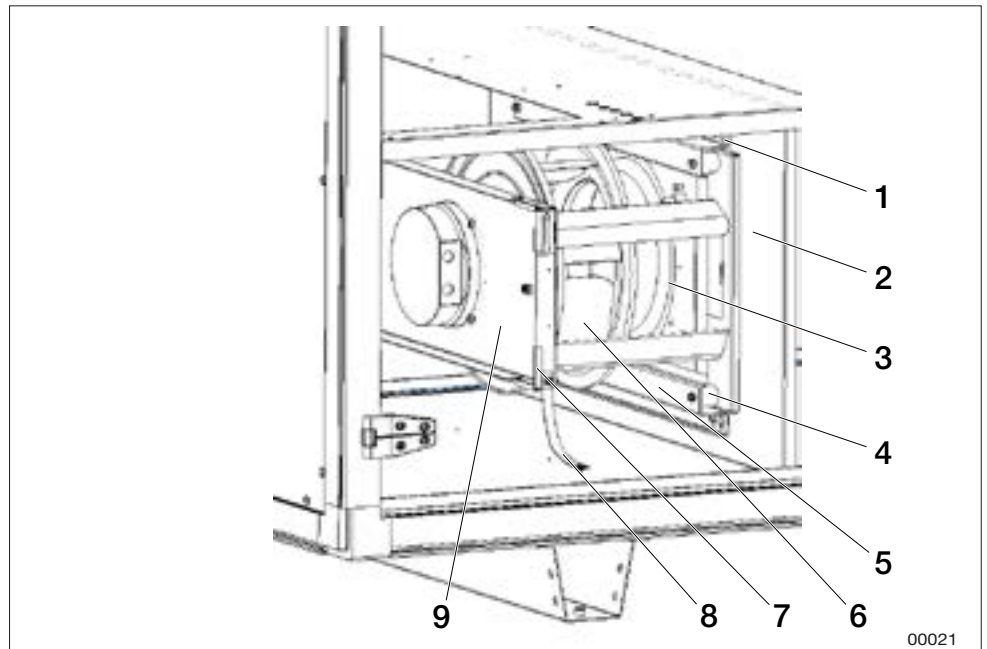

Example fan unit size 04-06 with fan impeller 025

1. Screws suspension
2. Connection plate
3. Inlet cone
4. Vibration damper
5. Vibration damper console
6. Fan impeller with motor
7. Edge cover
8. Earth braid
9. Mounting plate fan

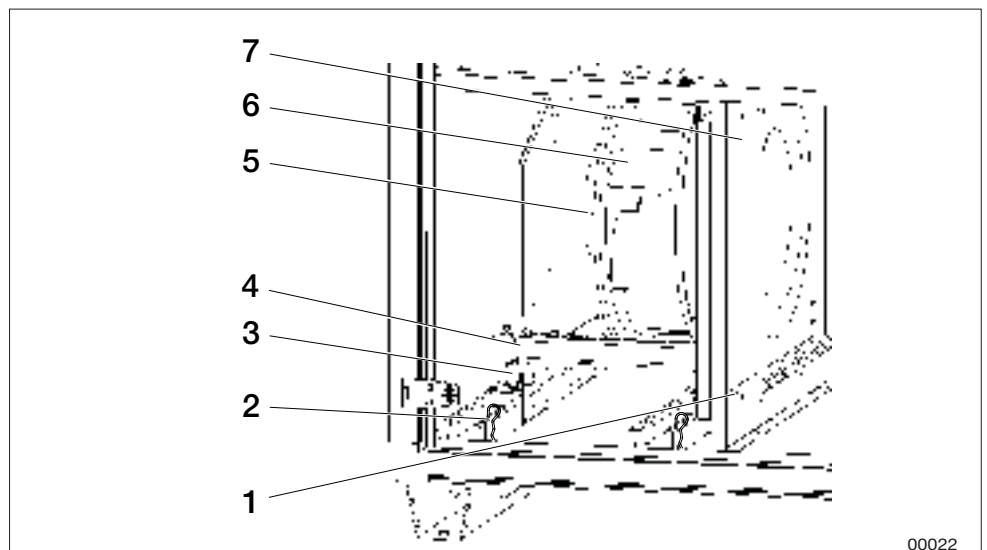

Example fan unit size 09-28

1. Screws side cover
2. Pins
3. Vibration damper
4. Earth braid
5. Motor
6. Fan impeller
7. Side cover



**WARNING!**  
**Risk of serious personal injury and/or damage to air handling unit.**  
**Read and understand the entire chapter "1 Security" before working on, servicing, or inspecting the air handling unit.**

1. Switch off the unit, see "5.3 Before maintenance (switch off the unit)" page 20.
2. Remove one end of the fan assembly's earth braid. If necessary, split the motor cable's quick connector.  
**For size 04 with fan impeller 020:** Open the snap locks (4) holding the fan assembly in place. Pull out the fan assembly.  
**For sizes 04-06 with fan impeller 025:** Remove the screws (1) in the connection plate (2) and unhook the fan unit from the keyholes in the anti-vibration supports (5), both upper and lower.  
**For size 09-28:** Loosen the screws (1) and the pins (2). Remove the side cover (6). Pull out the fan units (fan and motor are mounted on slide rails).
3. Check that the fan impeller rotates easily, is in balance and does not vibrate. Also check that the fan impeller is clean from any accumulation of particles. Imbalance may be due to a coating or damage to the fan impeller blades.
4. Listen to the sound from the motor bearings. If the bearings are in good condition, you will hear a slight purring sound. A scraping or pounding sound may mean that the bearings are damaged and service is then required.
5. **For sizes 04-06 with fan impeller 025:** Check that the fan impeller with motor (6) is firmly mounted in the upper fan support (8) and that it has not shifted sideways toward the inlet cone (3). Also check to make sure that the inlet cone is properly secured. Check that the anti-vibration mountings (4) are intact and are firmly fitted.
6. **For size 09-28:** Fan impeller (5) and motor (4) are mounted on a support equipped with rubber vibration dampers. Check that the vibration dampers (3) are intact and firmly fitted.
7. **For sizes 04-06 with fan impeller 025:** Make sure that the edge guard (7) on the mounting plate (8) is secure.
8. **For size 04-28 with fan impeller 025:** Check the mounting bolts, screws as well as the suspension devices and support.
9. Check that the gasket on the connection plate around the connection opening is intact and is firmly fitted.
10. Check that the measurement tubes are securely fitted on each measurement outlet.
11. Remount the fan units.
12. Check that the earth braid is attached to both ends.

13. Check the air flows by:

- reading the flow display on the Climatix display unit for units with control equipment (code MX).
- measuring  $\Delta p$  in the connections (measurement outlets) for flow measurement +/- for units without control equipment (code UC, MK, US).

Use the unit's air flow label and see which flow corresponds to the measured  $\Delta p$ .

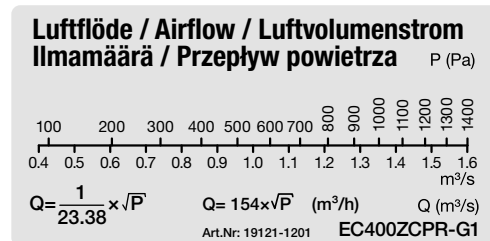

Example of air flow label

## Cleaning



### WARNING!

**Risk of serious personal injury and/or damage to air handling unit.**

**Read and understand the entire chapter "1 Security" before working on, servicing, or inspecting the air handling unit.**

1. Follow points 1-2 under *Inspection*.
2. Wipe the fan impeller blades to remove any coatings. Use a mild alkaline detergent.
3. The external surfaces of the motor must be kept clean from dust, dirt and oil. Clean with a dry cloth. For stubborn dirt, use a mild alkaline cleaner. The motor is likely to overheat inside if thick layers of dirt prevent air from entering the motor to cool the stator structure.
4. Vacuum clean the air handling unit so that particles will not be blown out into the duct system.
5. Clean the other parts in the same way as the fan impellers. Check that the inlet cones are securely mounted.
6. Follow points 11-12 under *Inspection*.

## 6.9 Damper (code ETSP-UM, ETSP-TR, ETRL)

- ETSP-UM Shut-off damper, rotary heat exchanger and counter-flow exchanger
- ETSP-TR Commissioning damper, rotary heat exchanger
- ETRL Return air damper, rotary heat exchanger

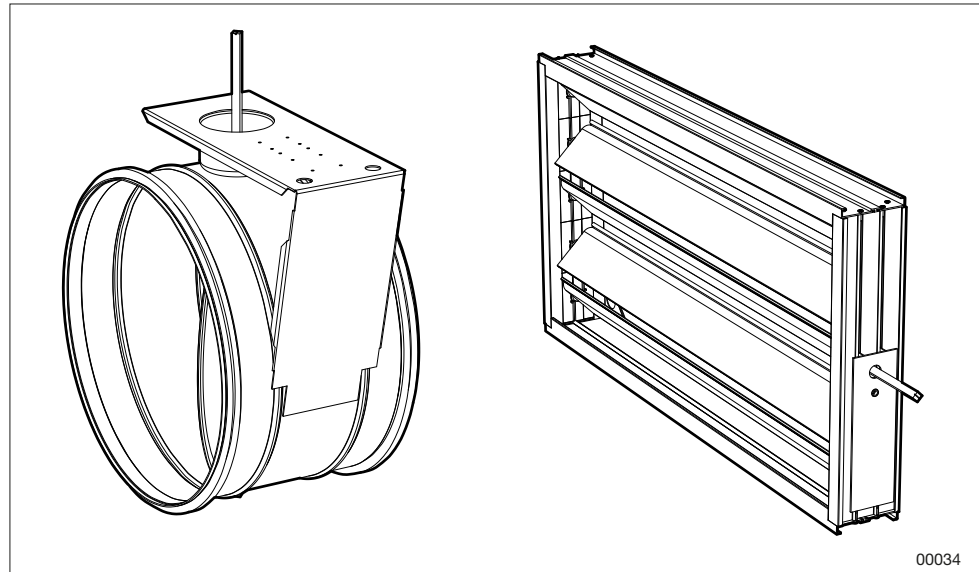

*Damper ETSP-UM, ETSP-TR and ETSP-UM, ETSP-TR, ETRL*

The purpose of the dampers is to regulate the air flow. Faulty function gives rise to disturbances that may result in serious problems.

- If the outdoor air damper does not open fully, the air flow is reduced.
- If the outdoor air damper leaks, this will result in increased energy use.
- If the outdoor air damper does not close completely when the unit stops, the air heating coil is likely to freeze.
- If the trim damper for the rotor purging function is not working or is incorrectly set, it may result in odours from the extract air being transferred to the supply air via the rotor.

### Inspection

	<p><b>WARNING!</b>  <b>Risk of serious personal injury and/or damage to air handling unit.</b>  <b>Read and understand the entire chapter "1 Security" before working on, servicing, or inspecting the air handling unit.</b></p>
---	---

- Check the function of the damper actuator.
- Check the dampers for tightness when they are closed. If they are not sealed, adjust the damper actuator to make the dampers tight (does not apply to trim dampers).
- Check the sealing strips.
- If the damper is not working, check that there are no screws penetrating the drive mechanism/damper blades to interfere with damper function.

## Cleaning



**WARNING!**

**Risk of serious personal injury and/or damage to air handling unit.**

**Read and understand the entire chapter "1 Security" before working on, servicing, or inspecting the air handling unit.**

Clean the damper blades with a cloth. In the event of stubborn dirt, use a mild, alkaline cleaner.

## 6.10 Sound attenuator (code ETLD)

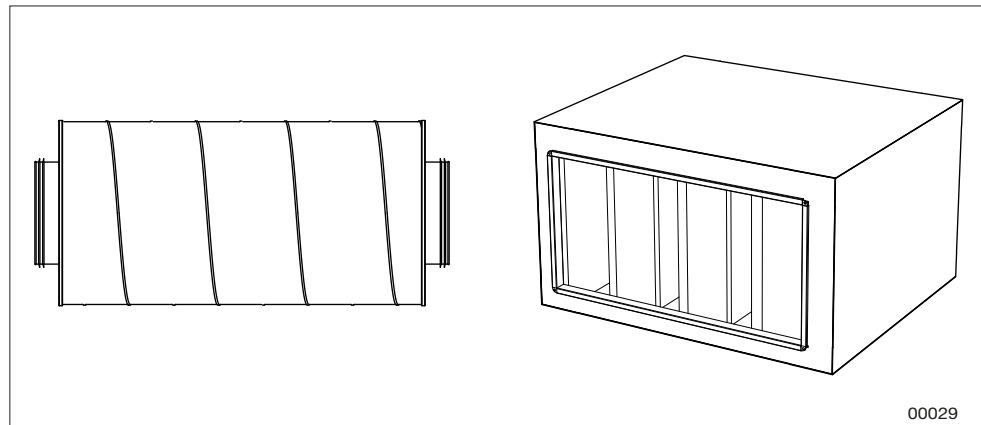

Circular sound attenuator TER-04 and rectangular size 04-28

The function of the sound attenuator is to reduce the sound level in the system.

### Inspection

	<p><b>WARNING!</b> Risk of serious personal injury and/or damage to air handling unit. Read and understand the entire chapter "1 Security" before working on, servicing, or inspecting the air handling unit.</p>
---	---

Check that the baffle elements are intact and have clean surfaces. Take action if necessary.

### Cleaning

	<p><b>WARNING!</b> Risk of serious personal injury and/or damage to air handling unit. Read and understand the entire chapter "1 Security" before working on, servicing, or inspecting the air handling unit.</p>
---	---

In order for the adhesive not to lose its adhesion between the surface layer and the underlying mineral wool, vacuum and/or wipe all surfaces gently. In the event of stubborn dirt, use a mild, alkaline cleaner.

## 6.11 Cooling unit (code TEC-R, TEC-M, TECX, TECO). Reversible heat pump (code TTC, TTCH)

### General

The operation parameters for the unit must not be changed unless a check is first made to ascertain that the changes will be within the unit's operating range.

### Visual check



**WARNING!**  
Risk of serious personal injury and/or damage to air handling unit.  
Read and understand the entire chapter "1 Security" before working on, servicing, or inspecting the air handling unit.

Check:

- The fins on the supply air coil/extract air coil for mechanical deformity.
- The drip tray and drain with water trap (clean if necessary).
- That the water trap without non-return valve is filled with water.
- That the non-return valve in a water trap with a non-return valve closes tightly.

### Cleaning



**WARNING!**  
Risk of serious personal injury and/or damage to air handling unit.  
Read and understand the entire chapter "1 Security" before working on, servicing, or inspecting the air handling unit.

If the fins on the batteries are dirty, clean them by vacuuming from the inlet side, or carefully blow them clean with compressed air from the outlet side. In the event of stubborn dirt, use a mild, alkaline detergent.

For more information, refer to [Cooling coil, cleaning](http://ivprodukt.docfactory.com) under Documentation at [ivprodukt.docfactory.com](http://ivprodukt.docfactory.com).

### Function

Check that the cooling unit operates as it should by temporarily lowering the temperature setting (setpoint). Cooling is blocked during weak air flow or when the outdoor temperature drops below the set value for cooling start.

### Refrigerant detectors

The detectors are self-calibrating and do not require set-up or maintenance.

## 7 Alarm management and troubleshooting

For units with control equipment (code MX), alarm information can be read on the Climatix display.

For units without control equipment (code UC, MK, US), alarm information can be read on the Carel display.

Press the alarm symbol to view alarms.

### 7.1 Cooling unit size 17-22 (code TEC)

#### Troubleshooting in the event of an alarm

Inspection	Possible cause	Corrective action
Is Carel "High pressure switch (16)" displayed?	YES ⇒ No or too low air flow across the condenser	Check the air flow across the condenser. Reset the pressure switch manually.
	Defective high-pressure switch	Check/replace. Call a certified refrigeration service.
NO ↓		
Is Carel alarm "LOP" displayed?	YES ⇒ Insufficient refrigerant volume	Look for leakage, seal the leak and top up with refrigerant. Call a certified refrigeration service.
	No or too low air flow across evaporator	Check/adjust the flow.
	Defective expansion valve or low pressure control	Check/replace. Call a certified refrigeration service.
NO ↓		
Is Carel alarm with figures (1)-(15), (17)-(29) displayed?	YES ⇒ Phase failure/voltage failure	Check incoming voltage (phase and neutral). Reset the frequency inverter by switching off the voltage for 1 minute or more. Check that the compressor is running without dissonance.
	Overload/defective stepless compressor	Reset the frequency inverter by switching off the voltage for 1 minute or more. Check that the compressor is running without dissonance.
NO ↓		
Contact support		



## Troubleshooting via symptoms

Symptom	Possible cause	Corrective action
Low cooling power – too high temperature in the cooled object/medium	The power supply has been interrupted	Check the control/safety switches and fuses.
	No or too low air flow across evaporator	Check that nothing is blocking the air flow.
	The control equipment is incorrectly preset/defective	Adjust the settings or replace the equipment.
	Compressor is not operating	See symptom “Compressor is not operating”.
Compressor is not operating	The power supply has been interrupted	Check the control/safety switches and fuses.
	Compressor has opened a safety circuit	Check and reset, if needed.
	The control unit is switched off	Start the control unit.
	Compressor defect	Check/replace. Call a certified refrigeration service.
Frost on the evaporator	The expansion valve is incorrectly preset/defective	Check/replace Call a certified refrigeration service.
	Insufficient refrigerant volume	Search to detect leakage, seal the leak and charge with refrigerant Call a certified refrigeration service.
	Low supply air flow	Adjust the flow.

## Alarm reset

In the event of an alarm initiated by the frequency inverter or the safety circuit, the compressor stops and the sum alarm relay is energised. The alarm is displayed in the control unit menus “Operating information, compressors” and “Status: Alarm”.

In the event of an alarm, the fault must be rectified, after which the control unit’s “Alarm reset” button must be pressed for at least 2 seconds. If the safety circuit alarm trips repeatedly, an authorised refrigeration service company must be contacted.



## 7.2 Cooling unit (size 06-12 code TEC-R) / (size 06, 10 code TEC-M) - without Carel

### Troubleshooting via symptoms

Symptom	Possible cause	Corrective action
The high pressure switch has tripped	No or too low air flow across the condenser	Check the air flow across the condenser. The high pressure switch may have tripped due to a momentary lack of air flow caused by e.g. a closed damper, clogged filter or incorrectly set time control program. Reset the pressure switch manually.
	Defective high pressure switch	Check/replace. Call a certified refrigeration service.
LOC alarm	Insufficient refrigerant volume	Look for leakage, seal the leak and top up with refrigerant. Call a certified refrigeration service.
	No or too low air flow across the evaporator	Check/adjust the flow.
	Defective expansion valve or low pressure control	Check/replace. Call a certified refrigeration service.
The LED is off or flashing green on the frequency inverter (see also information below)	Phase failure/voltage failure	Check the 1-phase supply, measure the incoming voltage. Check the high pressure switch by pressing the button. Reset the frequency inverter by switching off the voltage for 1 minute or more. Check that the compressor is running without dissonance.
	Overload/defective stepless compressor	Reset the frequency inverter by switching off the voltage for 1 minute or more. Check that the compressor is running without dissonance.

### Green light emitting diode (LED) on the inverter

There is a green LED on the inverter's circuit board to indicate status:

Off – No power supply or faulty power supply. If the LED is off in spite of correct power supply, there could be an internal fault in the inverter.

Lit – Normal mode, power supply is OK.

Flashing – The inverter is indicating a problem. Read off the alarm according to "Alarm information for inverter and compressor" page 63 and rectify.

## Alarm information for inverter and compressor

Alarm Climatix (code MX)	Alarm Carel (code UC, MK, US)	Explanation and corrective action
Peripherals	AL P02 Compressor Drive: PERIPHERALS_ERROR	Communication error with the electronic expansion valve. Compressor runs at limited speed.
Outside operating range	AL C01 Compressor Drive: OUT_OF_ENVELOPE	The compressor has worked outside its normal operating range for a long time and stopped. Automatic restart occurs after 60 seconds. After 10 repeated restart attempts, the error must be remedied and the alarm reset.
Overcurrent	AL H01 Compressor Drive: OVER_CURRENT	A too high current has been registered and the inverter stopped. The alarm may be caused by e.g. missing phase (power supply), earth fault, short circuit, compressor fault or internal fault in the inverter. The alarm needs to be reset after repeated start attempts.
High DC voltage	AL H02 Compressor Drive: DCLINK_VOLTAGE_HIGH	A too high voltage has been registered. The alarm may be caused by e.g. a power outage. After 10 repeated alarms, the error must be remedied and the alarm reset.
High inverter temp	AL H03 Compressor Drive: DRIVE_TEMPERATURE_HIGH	A too high temperature in the inverter has been registered (>115°C) and the inverter stopped. The alarm may be caused by e.g. a defective cooling fan, blocked air flow or abnormally high ambient temperature. The alarm needs to be reset.
Low supply voltage	AL H04 Compressor Drive: SUPPLY_VOLTAGE_LOW	A too low supply voltage has been registered (<180 V). Check the voltage level. When the voltage reaches normal level the inverter restarts. <b>The alarm may be the result of a tripped high pressure switch (the inverter loses all power). Reset by pressing the button on the pressure switch.</b>
High hot gas temp	AL D01 Compressor Drive: DISCHARGE_TEMP_HIGH	A too high refrigerant temperature has been registered. The inverter attempts to restart once normal temperature has been registered. After 10 restart attempts, the error must be remedied and the alarm reset.
Hot gas temp error	AL D03 Compressor Drive: DISCHARGE_TEMP_INVALID	Hot gas temperature signal is faulty. There is probably a fault with the wiring or sensor. The inverter is stopped and restarts when the fault is fixed.
MB communication error	AL D04 Compressor Drive: MODBUS_COM_TIMEOUT	The inverter has lost Modbus communication with Climatix control equipment and stopped. Check the high pressure switch by pressing the button. When communication is restored, the inverter is automatically started after 2 minutes.

MOC safety	AL D06 Compressor Drive: MOC_SAFETY	Motor Orientated Control has detected an error. The inverter is stopped. Errors must be remedied and alarms reset. <b>The alarm may be the result of a tripped high pressure switch (the inverter loses all power). Reset by pressing the button on the pressure switch.</b>
Low DC voltage	AL D07 Compressor Drive: DCLINK_VOLTAGE_LOW	The DC voltage in the inverter is too low. The inverter is stopped. When the voltage reaches the correct level the inverter restarts.
Low pressure error	AL D09 Compressor Drive: SUCTION_PRESS_INVALID	Faulty pressure signal for low pressure (suction side). There is probably a fault with the wiring or sensor. The inverter is stopped and restarts when the fault is fixed.
High pressure error	AL D10 Compressor Drive: CONDENSEPRESS_INVALID	Faulty pressure signal for high pressure. There is probably a fault with the wiring or sensor. The inverter is stopped and restarts when the fault is fixed.
High pressure low	AL D12 Compressor Drive: CONDENSER_PRESS_LOW	The pressure at the condenser is too low after starting. After 10 repeated alarms, the error must be remedied and the alarm reset.
Too many starts	AL D15 Compressor Drive: RESTART_TOO_FREQUENTLY	The compressor has been restarted too many times in a 10-minute period and the inverter stopped. The alarm needs to be reset. Check that the air flow is correct. Set the start delay for the compressor to 3 minutes after the compressor is turned off. For UC/MK/US: Check that the regulator that starts/stops cooling mode is not too fast so that the cooling mode hovers between ON and OFF. A maximum of six starts are permitted in 10 minutes; an alarm will be activated otherwise.
Internal inverter error	AL D16 Compressor Drive: INTERNAL_ERROR	An internal communication error has been registered and the inverter stopped. It is likely that the inverter cannot be restarted if this error occurs.
Cooling unit alarm: High pressure switch	AL C02 Compressor 1: Alarm	Alarm from tripped high pressure switch. <b>Reset by pressing the button on the pressure switch.</b>
Outdoor temp error	AL P01 B03 Ambient temp. probe fault or disconnected	The inverter does not receive a value for the ambient temperature and cannot regulate the compressor heat.
-	AL G01 Clock Board fault or not connected	-
-	AL G02 Extended memory Fault	-
Com.Modbus alarm Danfoss: Alarm	AL D18 Modbus communication: Compressor drive AOC	<b>The alarm may be the result of a tripped high-pressure switch (the inverter loses all power). Reset by pressing the button on the pressure switch.</b>
	AL D18 Modbus communication: Compressor drive MOC	
	AL D18 Modbus communication: Compressor drive EEV	

## High pressure switch alarm

If the high pressure switch has tripped, “Cooling unit alarm: Alarm” is displayed. Since the inverter loses all power when the high pressure switch is tripped, a communication error alarm is also displayed, “Com.Modbus alarm Danfoss: Alarm”.

## Alarm reset

- Manually reset alarms caused by a tripped high pressure switch by pressing the red button on the pressure switch.
- Reset alarms from the inverter or the compressor by turning off the power to the unit (inverter) for at least 1 minute.

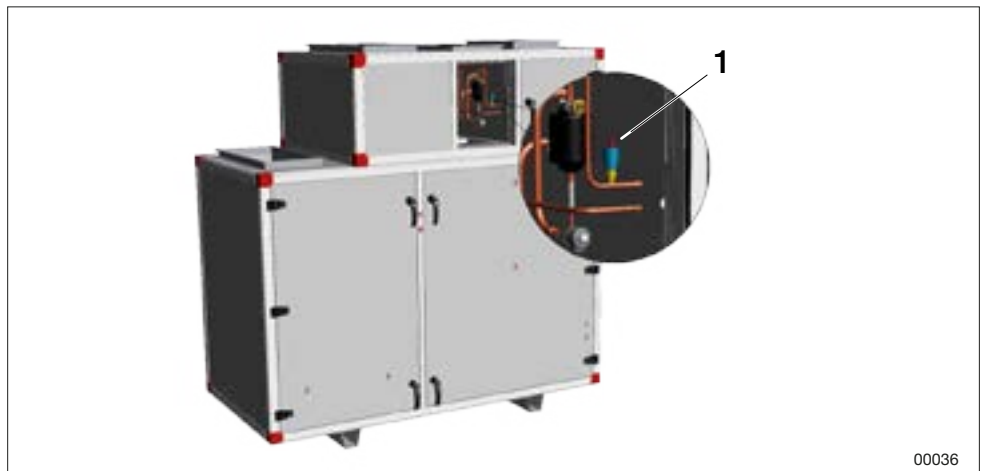

1. Reset button for pressostat



### 7.3 Cooling unit (size 04-12 code TEC-R) / (size 04-12 code TEC-M) / (size 17-28 code TECO, TECX) - with Carel. Reversible heat pump (code TTC, TTCH)

#### Alarm troubleshooting

Inspection	Possible cause	Corrective action
Has the high pressure switch tripped?	YES ⇒ No or too low air flow across the condenser	Check the air flow across the condenser. Rest the pressure switch manually.
	Defective high pressure switch	Check/replace. Call a certified refrigeration service.
NO ↓		
Is the alarm "118 Compr 1, Low evaporation pressure" or "176 Compr 2, LowEvap-Pressure" displayed?	YES ⇒ Insufficient refrigerant volume	Look for leakage, seal the leak and top up with refrigerant. Call a certified refrigeration service.
	No or too low air flow across evaporator	Check/adjust the flow.
	Defective expansion valve	Check/replace. Call a certified refrigeration service.
NO ↓		
Is the LED flashing red on the frequency inverter?	YES ⇒ Phase failure/voltage failure	Check the 3-phase supply, measure the incoming voltage. Reset the frequency inverter by switching off the voltage for 1 minute or more. Check that the compressor is running without dissonance.
	Overload/defective stepless compressor	Reset the frequency inverter by switching off the voltage for 1 minute or more. Check that the compressor is running without dissonance.
NO ↓		
Is the alarm "189 Phase Rotation order" displayed?	YES ⇒ Incorrect phase sequence for supply voltage on compressor 2	Shut off voltage and switch two of the incoming phases
NO ↓		
Is the alarm "94 Drive offline" displayed?	YES ⇒ ThermoCooler HP does not have supply voltage 3×400V	Connect supply voltage.

## Alarm information for inverter and compressor

Alarm Climatix	Explanation and corrective action
Sum alarm	Sum alarm, check alarm in Carel, see table below.
Alarm C1 R. pressure switch	High pressure switch tripped or alarm for frequency inverter.
Alarm C1 EEV motor fault	Fault on electrical connection to expansion valve.
Alarm C1 low pressure sensor	Open circuit or short circuit to low pressure sensor. Check connections on the Carel unit, wiring and sensors.
Alarm C1 suction gas sensor	Open circuit or short circuit to suction gas sensor. Check connections on the Carel unit, wiring and sensors.
Alarm C1 high pressure sensor	Open circuit or short circuit to high pressure sensor. Check connections on the Carel unit, wiring and sensors.
Alarm C1 low overheating	Compressor stoppage caused by low overheating.
Alarm C1 LOP	Compressor stoppage caused by low evaporation temperature.
Alarm C1 MOP	Compressor stoppage caused by high evaporation temperature.
Alarm C1 communication EVD	Fault on communication to EVD (expansion valve control).
Alarm C1 low suction gas temp	Low suction gas temperature.
Refrigerant leakage, supply air	Refrigerant has been detected at the cooling unit's/reversible heat pump's supply air coil. The unit's fans will automatically start provided that the 'Service Switch' is in the 'Auto' position.
Refrigerant leakage, extract air	Refrigerant has been detected at the cooling unit's/reversible heat pump's extract air coil. The unit's fans will automatically start provided that the 'Service Switch' is in the 'Auto' position.
Detector alarm, supply air, Busoffl	No communication with detector.
Detector alarm, extract air, Busoffl	No communication with detector.

Alarm Carel	Explanation and corrective action
76 Drive MainsPhaseLoss	Check that all three phases are connected to the frequency inverter.
81 Drive U_phaseLoss	
82 Drive V_phaseLoss	
83 Drive W_phaseLoss	
94 Drive offline	No communication with the frequency inverter. Check that the frequency inverter is energised with 3-phase 400V.
118 Compr 1, Low evaporation pressure	Circuit 1, low evaporation temp/pressure. Check leakage in cooling circuit.
121 Compr 1, High pressure switch	Circuit 1, high pressure switch tripped. Check air flow and fire damper.
180 Compr 1, High pressure switch	Circuit 1, high pressure switch tripped. Check air flow and fire damper.



## Troubleshooting via symptoms

Symptom	Possible cause	Corrective action
Low cooling power - too high temperature in the cooled object	The power supply has been interrupted	Check the control/safety switches and fuses.
	Separate supply not connected	Connect supply.
	None or too low air flow across evaporator	Check that nothing is inhibiting the air flow.
Compressor is not operating	The control equipment is incorrectly pre-set/defective	Adjust the settings or replace the equipment.
	The power supply has been interrupted.	Check the control/safety switches and fuses.
	Incorrect phase sequence (compressor 2)	Switch two of the incoming phases.
Frost on the evaporator	Compressor has opened a safety circuit	Check and reset, if needed.
	Defective compressor	Check/replace. Call a certified refrigeration service.
	Expansion valve is defective	Check/replace. Call a certified refrigeration service.
	Insufficient refrigerant volume	Search to detect leakage, seal the leak and charge with refrigerant Call a certified refrigeration service.
	Low return air flow	Adjust the flow.

## Alarm reset

In the event of an alarm initiated by the frequency inverter or the safety circuit, the compressor stops and the sum alarm relay is energised. The alarm is displayed in the control unit menus “Operating information, compressors” and “Status: Alarm”.

In the event of an alarm, take corrective action to correct the fault, and then press the “Alarm reset” button on the control unit for at least 3 seconds. If the safety circuit alarm trips repeatedly, an authorised refrigeration service company must be contacted.



## You are welcome to contact us

---



IV Produkt AB, Sjöddevägen 7, S-350 43 Växjö, Sweden  
+46 470 – 75 88 00  
[www.ivprodukt.se](http://www.ivprodukt.se), [www.ivprodukt.com](http://www.ivprodukt.com)  
[www.ivprodukt.no](http://www.ivprodukt.no), [www.ivprodukt.dk](http://www.ivprodukt.dk), [www.ivprodukt.de](http://www.ivprodukt.de)



### Support:

Control: +46 470 – 75 89 00, [styr@ivprodukt.se](mailto:styr@ivprodukt.se)  
Service: +46 470 – 75 89 99, [service@ivprodukt.se](mailto:service@ivprodukt.se)  
Spare parts: +46 470 – 75 86 00, [reservdelar@ivprodukt.se](mailto:reservdelar@ivprodukt.se)  
DU/Documentation: +46 470 – 75 88 00, [du@ivprodukt.se](mailto:du@ivprodukt.se)

---