

Air handling with focus on LCC

Operation and maintenance

Envistar[®] Compact



Air Handling Unit

Envistar Compact and Home Concept FTX Compact 04-16

Order number :

Project :

Translation of the original instructions

Unit specifications

Unit type

- ACER
- ACEC Output var. 1 2 3
- Home Concept model

Control equipment

- MX
- UC
- MK
- US

Unit parts and accessories

- Recovery rotor ACRR
- Air heater water
ECET-VV ECET-TV
- Air heater electric ECET-EV
Output var. 1 2 3
- Air cooler water
ECET-VK ECET-DX
- Damper ECET-UM, ECET-TR
- Sound attenuator ECET-LD

Size

- 04
- 06
- 10
- 16

Filter, supply air

- ePM10-65% (M5)
- ePM1-50% (F7)
- Black Ridge BR
- Excl. filter

Filter, extract air

- ePM10-65% (M5)
- ePM1-50% (F7)
- Aluminium filter AL
- Excl. filter



Air handling with focus on LCC

Table of Contents

1	Safety precautions	2
1.1	Lockable safety switch	2
1.2	Inspection doors	2
1.3	Electrical connection	2
1.4	Cooling unit	2
2	General	3
2.1	Intended use	3
2.2	Manufacturer	3
2.3	Designations	3
2.4	CE marking and EU Declaration of Conformity	4
2.5	Maintenance	5
2.6	Handling of refrigerant	5
2.7	Extended warranty	6
2.8	Spare parts	6
2.9	Dismantling and decommissioning	6
3	Technical description	7
3.1	Envistar Compact air handling unit	7
3.2	Home Concept	7
4	Function	8
4.1	Cooling circuit	8
4.2	Controlling the StarCooler cooling unit (code ACEC)	9



Air handling with focus on LCC

Table of Contents, cntd

5	Wiring instructions and fuse protection	10
5.1	MX – Complete control equipment and UC – Complete electrical connection to terminal (without DUC).	10
5.2	MK – Fans and heat exchangers electrically connected to terminal	10
5.3	HS, US - Without control and without electrical connection	11
6	Operation	12
6.1	Hygiene inspection	12
6.2	Actions in case of standstill	12
6.3	Commissioning	13
7	Maintenance instructions	14
7.1	Service schedule	14
7.2	Filter (code ACEF)	16
7.3	Rotary heat exchanger (code ACRR)	20
7.4	Air heater water (ECET-VV) and Thermoguard (ECET-TV)	23
7.5	Air heater electric (code ECET-EV)	25
7.6	Air cooler water (code ESET-VK) Air cooler for direct expansion (code ECET-DX)	26
7.7	Fan unit	27
7.8	Damper (code ECET-UM, ECET-TR)	32
7.9	Sound attenuator (code ECET-LD)	33
7.10	StarCooler cooling unit (code ACEC)	34
8	Troubleshooting	35
8.1	StarCooler cooling unit (code ACEC)	35



Air handling with focus on LCC

1 Safety precautions

Observe warning labels on the unit as well as the following safety precautions:

1.1 Lockable safety switch



WARNING!

High voltage and rotating fan impeller, risk of personal injury. Working on/servicing the unit – Shut down the unit via the service switch in the control equipment, then turn the safety switch to the 0 position and lock it.

NB:

The safety switch is not designed for starting/stopping the unit. Always use the service switch in the control equipment to start and shut down the unit.

1.2 Inspection doors



WARNING!

Positive pressure inside the unit, risk of personal injury. Allow the pressure to drop before you open the inspection doors.



WARNING!

Rotating fan impeller, risk of personal injury. Shut down the unit via the service switch in the control equipment, then turn the safety switch to the 0 position and lock it. Wait at least 3 minutes before opening inspection doors.

NB:

The doors in front of moving parts should normally be locked; there are no safety guards. Before carrying out work, unlock the doors with the key provided.

1.3 Electrical connection



WARNING!

Rotating fan impeller, risk of personal injury. The unit must not be energised until all ducts have been connected.

NB:

Wiring of connections and other electrical work may only be carried out by a qualified electrician or by service personnel recommended by IV Produkt.

1.4 Cooling unit



WARNING!

Hot surfaces, risk of personal injury. Shut down the unit via the service switch in the control equipment, then turn the safety switch to the 0 position and lock it. Wait at least 30 minutes before opening the compressor inspection doors.

2 General

2.1 Intended use

The air handling units in the Envistar Compact series are intended for comfort ventilation in buildings.

2.2 Manufacturer

The Envistar air handling units (AHUs) are manufactured by:

IV Produkt AB
 Sjöuddevägen 7
 SE-350 43 VÄXJÖ

2.3 Designations

The Envistar Compact is manufactured as a compact unit, and the StarCooler cooling unit can be integrated as an optional extra.

The compact unit and cooling unit (if selected) have a model type plate affixed to the front.

The model type plate shows the series number and the requisite designations to identify the unit.

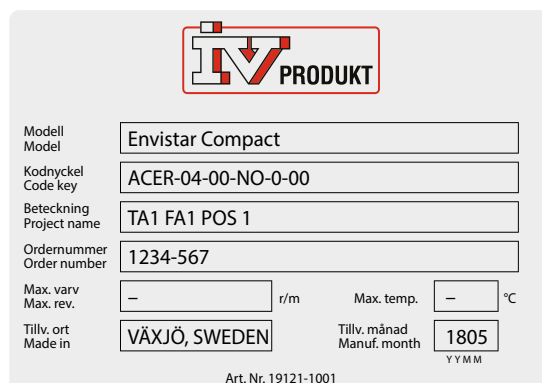

The image shows a typical model identification label for the Envistar Compact. It features the IV PRODUKT logo at the top. Below the logo, there are several fields for identification data:

Modell Model	Envistar Compact		
Kodnyckel Code key	ACER-04-00-NO-0-00		
Beteckning Project name	TA1 FA1 POS 1		
Ordernummer Order number	1234-567		
Max. varv Max. rev.	—	r/m	Max. temp. — °C
Tillv. ort Made in	VÄXJÖ, SWEDEN	Tillv. månad Manuf. month	1805 YYMM

Art. Nr. 19121-1001

Typical model identification label

2.4 CE marking and EU Declaration of Conformity

The air handling units and cooling unit (if selected) are CE marked, which means that upon delivery they conform to applicable provisions in EU Machinery Directive 2006/42/EC as well as to other EU Directives applicable to the types of air handling units, e.g. Pressure Equipment Directive PED 2014/68/EU.

As certification confirming that the requirements have been met, we provide an EU Declaration of Conformity, which is available under Documentation at ivprodukt.docfactory.com, or under Order Unique Documentation at docs.ivprodukt.com.

The CE marking applies to units that IV Produkt AB manufactures and supplies in the form of a unit without additional control equipment. For the CE marking of IV products to apply, the applicable requirements of the EU Machinery Directive 2006/42/EC and related directives for control equipment shall be met when installed for the unit.



Typical CE label for air handling units

Cooling unit

Order number

Code Key

Model

Name of project

Date of manufacture

PS Max allowable pressure bar (e)

PT Test pressure bar (e)

TS Temperature range °C

Protection level - low bar (e)

Protection level - high bar (e)

Refrigerant / Fluid group

GWP

Refrigerant charge Circuit 1 kg ton CO₂e

Refrigerant charge Circuit 2 kg ton CO₂e

Refrigerant charge Circuit 3 kg ton CO₂e

Contains fluorinated greenhouse gases covered by the Kyoto protocol.

CE
0409 IV Produkt AB
VÄXJÖ, SWEDEN

Typical CE label for cooling units

2.5 Maintenance

Continuous maintenance of this unit can be carried out either by the person normally in charge of maintaining the building or through a contract with a well-reputed service company.

2.6 Handling of refrigerant

The following information summarises the requirements and guidelines for handling the refrigerant used in cooling units. For further information, see the F-gas Regulation (EU/517/2014 on fluorinated greenhouse gases) and the Swedish Refrigerant Regulation (SFS 2016:1128). The purpose of the regulations is to contribute to achieving EU goals for reduced climate impact in accordance with the Kyoto Protocol.

Operator responsibilities

Generally speaking, the unit operator must:

- Minimise and prevent leakage
- Take corrective action to remedy any leakage that arises
- Ensure that the service and repair of the refrigerant circuit is carried out by a certified refrigeration technician
- Ensure that refrigerant is handled in an environmentally secure manner and in accordance with national regulations.

By operator, we refer to the European Parliament's definition: "...the natural or legal person exercising actual power over the technical functioning of the equipment and systems...".

Leakage inspection and registration

The following applies to compact units with 5 CO₂ e(tonnes) refrigerant content or more per circuit – Envistar Compact with StarCooler (code ACEC, size 16):

- **Leakage inspection** must be carried out by a certified refrigeration technician:
 - When installing/commissioning the unit
 - Periodically at least once per 12 months, i.e. no more than 12 months between inspections
 - within one month of any work being performed (e.g. sealing a leak, replacing a component).
- The operator must **record** events, such as the volume and type of refrigerant topped up, refrigerant taken into possession, results of inspections and work done, person and company who carried out service and maintenance.

If the total refrigerant content is below 5 CO₂ e (tonnes), no periodic leak detection or record keeping is needed, but the requirement for leak inspection during installation does apply.

2.7 Extended warranty

In cases in which the equipment delivered falls under a 5-year warranty, in accordance with ABM 07 with supplement ABM-V 07 or in accordance with NL 01 with supplement VU03, the IV Produkt Service and Warranty Manual is supplied with the product.

In order to lay claim to an extended warranty, a complete, documented and signed IV Produkt Service and Warranty Manual must be presented.

2.8 Spare parts

Spare parts and accessories for this unit are ordered from your nearest IV Produkt sales representative. When ordering, state the order number and designation. These are stated on a model type plate, affixed to each component. There is a separate spare parts list for the unit, refer to Order Unique Documentation at docs.ivprodukt.com.

2.9 Dismantling and decommissioning

When an air handling unit is to be dismantled, separate instructions must be followed, see [Air handling unit, dismantling and decommissioning](#) under Documentation at ivprodukt.docfactory.com.

3 Technical description

3.1 Envistar Compact air handling unit



Envistar Compact is fabricated as a packaged unit in various sizes as a right- or left-handed version. All units are equipped with rotary heat exchangers and are available as outdoor models. The units can be connected to ducts at the ends or via two of the connections at the top.

The units are usually supplied with integrated control equipment, but can also be obtained without control equipment.

3.2 Home Concept

The Home Concept version of the units have, among other things, specially adapted control equipment and air balancing dampers for the extract air. A filter cabinet for aluminium or carbon filters is available as an optional extra.

Envistar Compact with rotor and cooling unit is not available in the Home Concept version.

4 Function

4.1 Cooling circuit

From the compressor (position 1) the refrigerant is pressed as hot gas to the condenser (position 2) where heat is emitted. The refrigerant condenses from gas to liquid when it is cooled by the extract air.

The refrigerant passes the pressure reducing expansion valve (position 7) and undergoes a phase transformation in the evaporator (position 8) from liquid to gas (the refrigerant evaporates).

Inside the evaporator (position 8), the refrigerant absorbs the heat required for phase transformation. The heat is taken from the supply air which is thus cooled.

The cold refrigerant in gaseous form is drawn back into the compressor (position 1) where it is compressed and thus heated. The gas is also used for cooling the compressor's electric motor. The refrigerant now contains both the heat from the supply air, the compressor's motor heat and the compression heat.

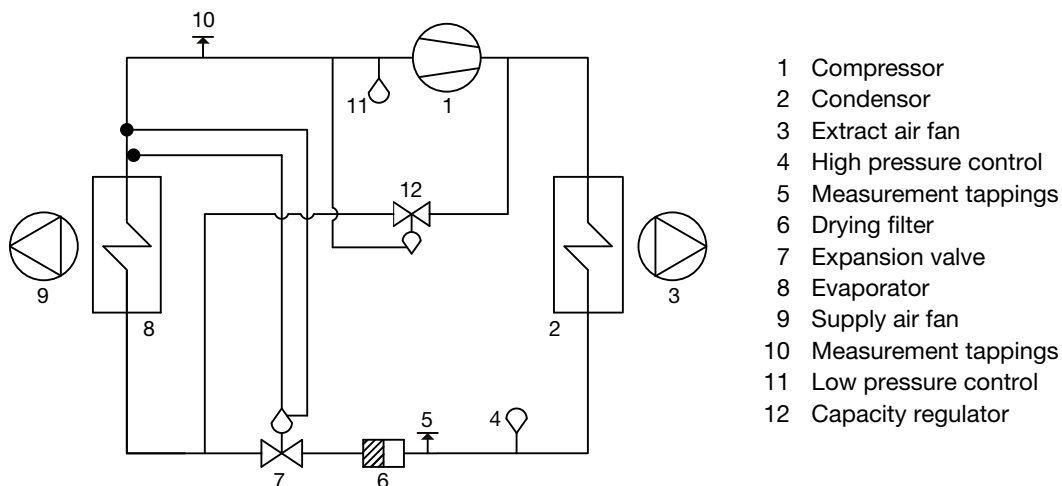

Flow chart for refrigerant system

4.2 Controlling the StarCooler cooling unit (code ACEC)

The cooling unit is equipped with a reciprocating compressor.

Function

Function COOL

The cooling compressor starts when potential-free contact closes from the control unit.

Interlocking

The compressor is interlocked across the ventilation unit. When the ventilation unit stops, the potential-free connector opens for cooling mode and the compressor stops.

Compressor protection

In the event of overcurrent, or if the safety circuit alarm trips the motor protection, the compressor stops, the connector for the sum alarm closes and alerts the control unit.

In the event of an alarm, correct the fault and reset the protective motor switch.

NB:

The high pressure switch has a manual reset button.

The safety circuit alarm will trip in the event of two different faults.

- High pressure in the system, HP
- Low pressure in the system, LP

If the safety circuit alarm trips repeatedly, an authorised refrigeration service company must be called in.

Electrical connection

The junction box contains the following:

- Motor circuit breaker
- Contactor
- Starting equipment

The junction box is mounted inside the cooling unit and has been internally prewired and tested at the factory.

5 Wiring instructions and fuse protection

5.1 MX – Complete control equipment and UC – Complete electrical connection to terminal (without DUC).

Applies to:

- units supplied prewired with complete, integrated Siemens Climatix control equipment (code MX).
- units supplied without process unit (DUC) but with sensor and damper actuator connected electrically to the terminal (code UC). Fans and heat exchangers are fused and connected electrically to the terminal. The terminal connections are positioned at a shared place in the unit. For further connection to an external process unit, we recommend using a multi-conductor cable.

Safety switch

A safety switch must be fitted and wired on each power supply.

Wiring diagrams

For wiring diagrams for units with integrated control equipment, refer to the order unique wiring diagram supplied with the unit or docs.ivprodukt.com (Control Diagram).

Unit functions, power supply and fuse protection

For power supply to the unit functions and recommended fuses, refer to Order Unique Documentation at docs.ivprodukt.com (Technical Data and Control Diagram), or the product program IV Produkt Designer.

5.2 MK – Fans and heat exchangers electrically connected to terminal

For units supplied without control equipment but with fans and heat exchangers connected electrically to terminals (code MK).

Connections to terminal blocks are located on each unit section.

For wiring instructions and recommended fuses, refer to Order Unique Documentation at docs.ivprodukt.com (Terminal Connection and Technical Data).

Safety switch

A safety switch must be fitted and wired on each power supply.

5.3 HS, US - Without control and without electrical connection

- For units without control equipment and without electrical connection (code HS), a control diagram is available for the cooling unit (code ACEC) at docs.ivprodukt.com, for other connection instructions, see below.
- For units without control equipment and without electrical connection (code US), refer to the connection instructions below.

Safety switch

A safety switch must be fitted and wired on each power supply.

Fan, sizes 04 and 06

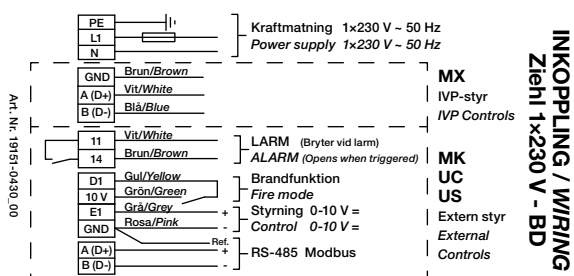

Fan, sizes 10 and 16

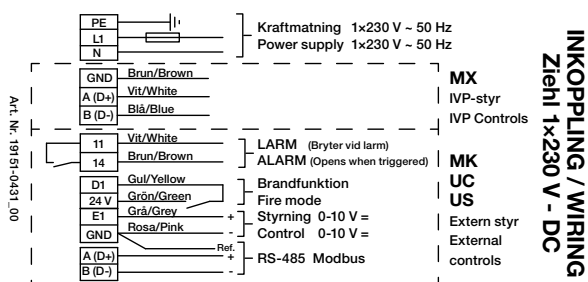

Rotary heat exchanger (code ACRR)

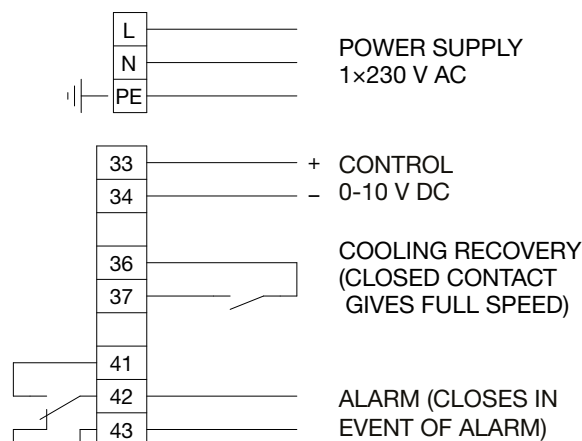

Air heater electric (code ECET-EV)

For power supply, output variant and recommended fuse, refer to Order Unique Documentation at docs.ivprodukt.com (Technical Data).

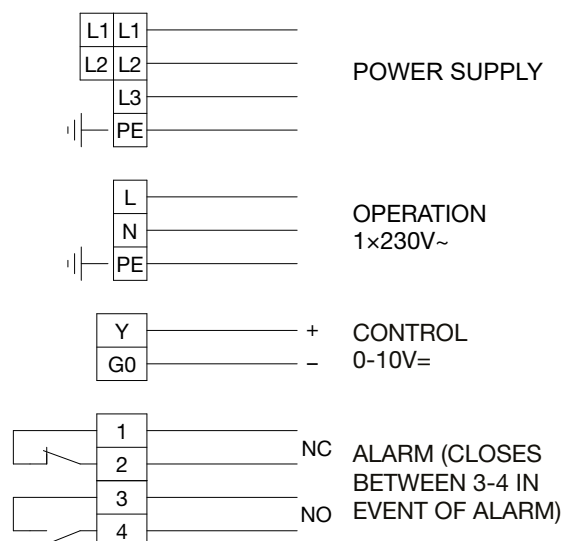

6 Operation

6.1 Hygiene inspection

Envistar Compact conforms to guidelines in VDI 6022 Part 1: Hygiene and Hygiene Inspections of HVAC Systems.

For this to apply, a hygiene inspection of the system must be carried out and the system must be cleaned thoroughly as needed before start-up.

For units (code MK, US,UC):

NB:

Pressure surges on filters and air ducts must be prevented through the design of the duct system and the settings/configuration of the control system (e.g. soft start of fans, open damper when the fans are in operation).

6.2 Actions in case of standstill

According to guidelines for hygienic design VDI 6022 Part 1:

In case of prolonged standstill in air treatment systems (more than 48 hours), it should be ensured that no moist areas can be found downstream from the cooling coils or humidifier.

In order to avoid the accumulation of moisture – turn off the cooling coils and humidifier in good time and ventilate the air ducts dry (gradual shut-down). Also, be sure to set up or program the required functions in the building's automation/control system for automatic dry blowing of air coolers and downstream sections.

6.3 Commissioning

Envistar Compact with rotor (code ACER) and Envistar Compact with rotor and cooling unit StarCooler (code ACEC) are factory-assembled compact units that are tested and documented at the factory.

Commissioning of the unit must be carried out by competent personnel according to the [Commissioning Checklist for air handling units](http://ivprodukt.docfactory.com), which can be found at ivprodukt.docfactory.com.

The commissioning procedure applies to units that are supplied with control equipment (code MX).

Installation of cooling units requires leak inspection by a certified cooling technician.

The validity of the product warranty is conditional on the system having been correctly commissioned. Working on the cooling unit during the warranty period without the approval of IV Produkt shall render the warranty void.

Prior to commissioning, the contractor must:

NB:

Wiring of connections and other electrical work may only be carried out by a qualified electrician or by service personnel recommended by IV Produkt.

1. Connect the unit to the power supply via a lockable safety switch.
2. Connect the heating/cooling coil.
3. Connect all ducts.



WARNING!

Rotating fan impeller. The unit must not be energised until all ducts have been connected.

Follow the troubleshooting instructions in the troubleshooting chart before contacting a service representative for servicing a unit under warranty. This will prevent any unnecessary service calls.









7 Maintenance instructions

7.1 Service schedule

The service schedule comprises actions and service intervals for functional sections that can be part of the air handling unit. The unit consists of one or more of these functional sections. The relevant sections are marked on the list in the table of contents.

Make copies of the service schedule for future use before you fill in servicing data for the first time.

For hygiene inspections according to guideline VDI 6022, see separate [Checklist for Operation and Maintenance, Hygiene checks](http://ivprodukt.docfactory.com) at ivprodukt.docfactory.com.

Service year 20..... - for unit no.				Service performed * (date and signature)			
Functional section	Code	Recommended action (insp.)	Page ref.	3000 h / 6 mths	6000 h / 12 mths	9000 h / 18 mths	12,000 h / 24 mths
				date	date	date	date
 Filter supply air, extract air	ACEF	Check pressure drop Change filter if necessary	14	signature	signature	signature	signature
 Rotary heat exchanger	ACRR	Visual inspection Check press. balance Check diff. pressure Clean if necessary	16	signature	signature	signature	signature
 Air heater water	ECET-VV, ECET-TV	Visual inspection Clean if necessary Check function	19	signature	signature	signature	signature
 Air heater electric	ECET-EV	Visual inspection Clean if necessary Check function	20	signature	signature	signature	signature
 Air cooler water	ECET-VK, ECET-DX	Visual inspection Check drainage Clean if necessary Check function	21	signature	signature	signature	signature
 Fan unit	-	Visual inspection Clean if necessary Check the air flow	22	signature	signature	signature	signature
 Damper	ECET-UM, ECET-TR	Visual inspection Clean if necessary Check tightness	25	signature	signature	signature	signature
 Sound attenuator	ECET-LD	Visual inspection Clean if necessary	26	signature	signature	signature	signature

* Every 3,000th hour in operation or every 6th month depending on which occurs first. More frequent servicing may be required in certain environments.

Cooling unit



For units equipped with cooling units.

Service year 20..... - for unit no.					Service performed * (date and signature)			
Functional section	Code	Recommended action (insp.)	Page ref.	3000 h / 6 mths	6000 h / 12 mths	9000 h / 18 mths	12,000 h / 24 mths	
				date	date	date	date	
	Cooling unit	ACEC	Visual inspection Check drainage Clean if necessary Check function Check for leakage and report if necessary	27	signature	signature	signature	signature

* Every 3,000th hour in operation or every 6th month depending on which occurs first. More frequent servicing may be required in certain environments.

Home Concept

For the Home Concept version.

Service year 20..... - for unit no.					Service performed * (date and signature)			
Functional section	Code	Recommended action (insp.)	Page ref.	3000 h / 6 mths	6000 h / 12 mths	9000 h / 18 mths	12,000 h / 24 mths	
				date	date	date	date	
	Aluminium filter in filter cabinet	ACET-08F-size-AL	Check pressure drop Clean if necessary	14	signature	signature	signature	signature
	Carbon filter in filter cabinet	ACET-08F-size-BR	Inspection indication Replace if necessary	14	signature	signature	signature	signature

* Every 3,000th hour in operation or every 6th month depending on which occurs first. More frequent servicing may be required in certain environments.

7.2 Filter (code ACEF)

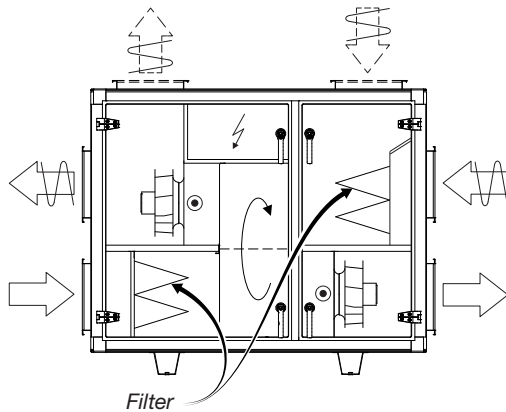

The air filters in an air handling unit are designed to prevent dust and other impurities from entering the building. They should also protect sensitive components inside the unit, e.g. water coils and heat exchangers, from exposure to impurities.

The dust separation efficiency varies considerably between various filter types. The dust collecting efficiency also varies substantially. It is therefore important to use filters of the same quality and capacity when you change them.

According to guidelines for hygienic design VDI 6022 Part 1: The supply air filter must be class ePM1-50% (F7) or have a greater filtration efficiency.

The filters are designed for one-time use. If they become fouled, the unit will lose capacity. The filters should therefore be changed if the pressure drop across them exceeds the specified final pressure drop.

It is important to stop the unit before changing filters to prevent dust from coming loose and being drawn into the unit. The inside surfaces of the filter sections should therefore also be cleaned when the filters are changed.

For the Home Concept version (code ACET-08)

The filter cabinet is an optional extra for the Home Concept version and can be used for

- aluminium filter on the extract air side
- carbon filter on the supply air side

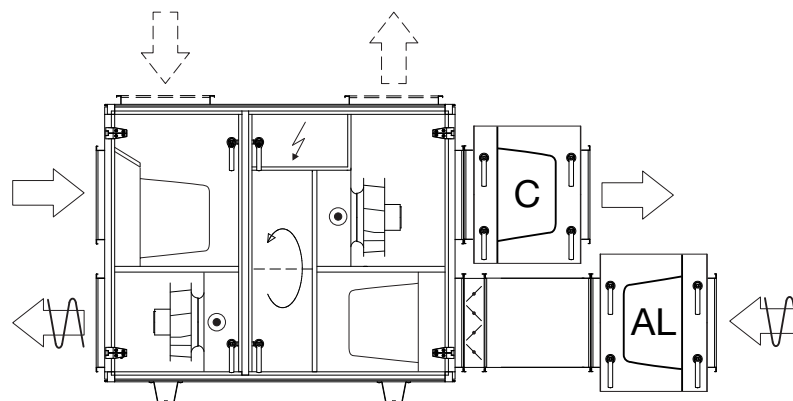

AL - aluminium filter, C - carbon filter, Black Ridge

The aluminium filter is intended for use where the extract air contains grease particles to avoid grease being sucked into the unit. The filter is a knitted flat-type filter. The aluminium filter can be cleaned using hot water and a mild alkaline detergent.

The carbon filter can be used to remove odours in the form of organic and odorous gases/vapours. The carbon filters are fitted to the supply air side. The carbon filters are Black Ridge filters, constructed as compact and highly efficient, molecular filters. The filters are designed for one-time use and the filter is combustible in its entirety.

Lifespan and filter control Carbon filter

The function and lifespan of the carbon filters depends on the volume of air that passes through and on the molecular density of odorous substances. This means that the time intervals for filter replacement can vary from unit to unit depending on operation mode and the volume of odorous substances in the air.

Units delivered with integrated control equipment (code MX) are equipped with the filter control function – FLC (Filter Lifetime Control). FLC indicates when it is time to replace the carbon filter. Indication is through an alarm on the hand-held terminal display.

FLC calculates the volume of air passing through the carbon filters and triggers the alarm for filter replacement when the preset value has been reached. The volume of air passing through is measured in mega cubic metres (Mm³). The function does not take into account the odour content of the air, which means that the indication should be regarded as a recommendation for checking the filter function. If no odours pass through, there is no need to replace the filter.

Preset FLC values, as per the table below, are based on max. air flow over 12 months of full-time operation. If required, the value can be lowered in order to: - change to more frequent filter replacement intervals for max. air flow - retain the filter replacement interval of 12 months for lower air flows.

To change the value, see separate Climatix control documentation.

Filter data

For filter data, refer to [Filter Overview](#) under Documentation at ivprodukt.docfactory.com. Actual filters are shown in the unit specification in this document and under Order Unique Documentation at docs.ivprodukt.com (Technical Data and Spare Parts List).

Inspection

Check the pressure drops across the filters (not carbon filter Black Ridge in Home Concept version). Pressure drops are measured with a pressure gauge connected to the measurement outlets. The measurement outlets are connected to each side of the filter.

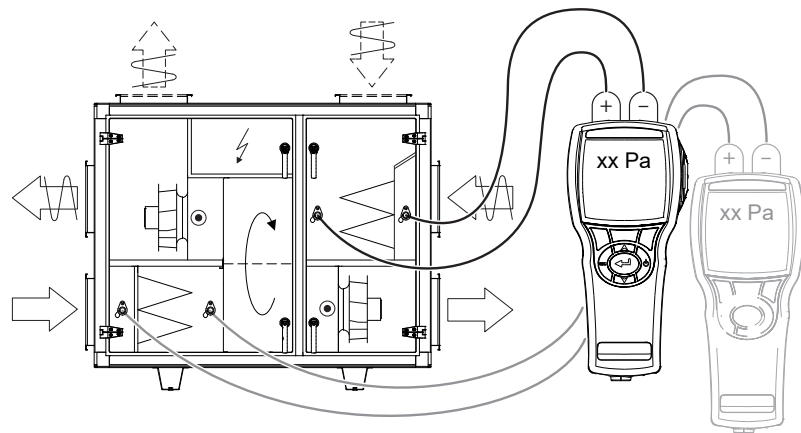

If the filter has reached its specified final pressure drop, it should be changed. The final pressure drop is specified on the filter section decal (filled in when the air handling unit is put into operation).

Also carry out a visual inspection of the filter for damage and deposits.

FILTERDATA	
Nominellt luftflöde	<input type="checkbox"/> m ³ /s
Nominal air flow.....	<input type="checkbox"/> m ³ /h
Antal filter	Mått
Number of filters.....	Dimensions.....
.....
.....
Filterklass/Filter Class.....	
Begynnelsestryckfall	
Initial Pressure Drop.....Pa
Sluttryckfall	
Final Pressure Drop.....Pa

Art. Nr: 19121-1101_02SV

Filter replacement

1. Shut down the unit via the service switch in the control equipment, safety switch in the 0 position.

NB:

The safety switch is not designed for starting/stopping the unit. Always use the service switch in the control equipment to start and shut down the unit.

2. Wait until the fans have stopped, then open the inspection door.



WARNING!

Positive pressure inside the unit, risk of personal injury. Allow the pressure to drop before you open the inspection doors.

3. Release the eccentric rails.
4. Remove the old filter by pulling it towards you.
5. Clean the filter cabinets.
6. Install the new filter, press in the eccentric rails to engage them and close the inspection door.
7. Reset the FLC filter control function via the Climatix display, refer to separate Climatix control documentation. (Only applicable to the Home Concept version of the unit with carbon filter and integrated control equipment (code MX).)
8. Start the unit.

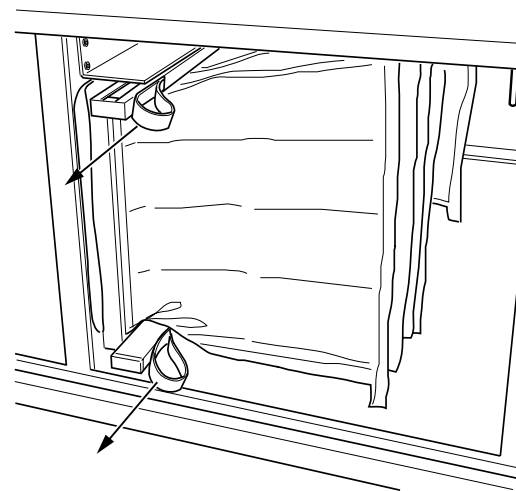

Eccentric rails inside the unit

7.3 Rotary heat exchanger (code ACRR)

The purpose of the recovery unit is to recover heat from the extract air and transfer this heat to the supply air in order to minimise energy use.

Faults in heat exchanger functionality result in reduced heat recovery efficiency and increased energy use and means that the design supply air temperature cannot be obtained when the outdoor temperature is low.

A conceivable reason for reduced recovery efficiency may be that the rotor rotates too slowly because the drive belt is slipping. Rotation should not be lower than 8 RPM during full energy recovery.

It is not usual for the rotor passages to become fouled with dust, since the rotor is normally self-cleaning. However, this might occur if the dust is of a sticky nature.

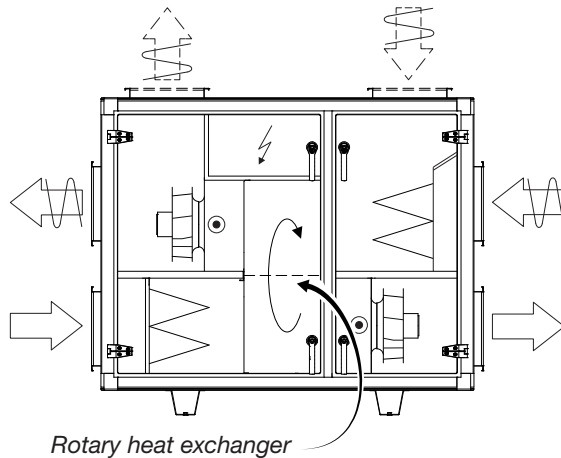

A reduction of the extract air flow, e.g. due to fouling of the extract air filter, entails reduced heat recovery efficiency.

The Home Concept version of the units is equipped with a control function for the pressure balance over the purge sector, which means that the pressure balance does not have to be inspected or adjusted. For units supplied with integrated control equipment, the function is connected and activated at the factory. For units not supplied with control equipment this function has to be connected to the unit.

Inspection

1. Shut down the unit via the service switch in the control equipment, safety switch in the 0 position.

NB:

The safety switch is not designed for starting/stopping the unit. Always use the service switch in the control equipment to start and shut down the unit.

2. Wait until the fans have stopped, then open the inspection door.



WARNING!

Positive pressure inside the unit, risk of personal injury. Allow the pressure to drop before you open the inspection doors.

3. Check that the rotor rotates easily. If it is sluggish, you might have to adjust the bristled sealing strip.
4. Check that the rotor's bristled sealing strip seals against the side plates and that it is not worn. The bristled sealing strip is subject to wear and can be adjusted or replaced if the need arises.
5. Check that the drive belt is properly tensioned and does not slip. If it slips, it will have to be shortened. The rotor speed should not be lower than 8 RPM during full energy recovery.
6. Check that the drive belt is intact and clean.
7. Check that the rotor's inlet surfaces are not covered with dust or other impurities. NB: Avoid touching the rotor inlet and outlet surfaces with your hands or tools.

8. Check the pressure balance (not applicable to the Home Concept version). To ensure correct function of the purging sector, the negative pressure at P3 should be greater than the negative pressure at P2 (min. diff. 25 Pa). Otherwise an ETET-TR trim damper can be used on the extract air side in order to throttle in the correct pressure balance.

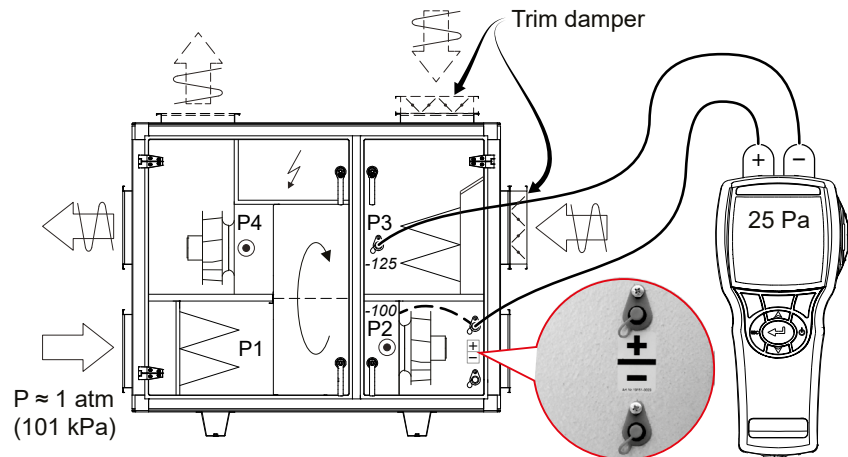

P2: Downstream supply air fan generates negative pressure in relation to the atmospheric pressure (atm), e.g. -100 Pa

P3: Downstream extract air fan and any trim damper generate greater negative pressure than at P2, e.g. -125 Pa

9. Check the differential pressure across the rotor. The purging sector is factory-installed, set to the maximum open position. Depending on the unit's pressure ratios, the purging sector may need adjustment. An incorrect setting may impair the efficiency. Inspection and adjustment should be carried out as follows:

- Measure and write down the differential pressure between the outdoor air (P1) and the extract air (P3).

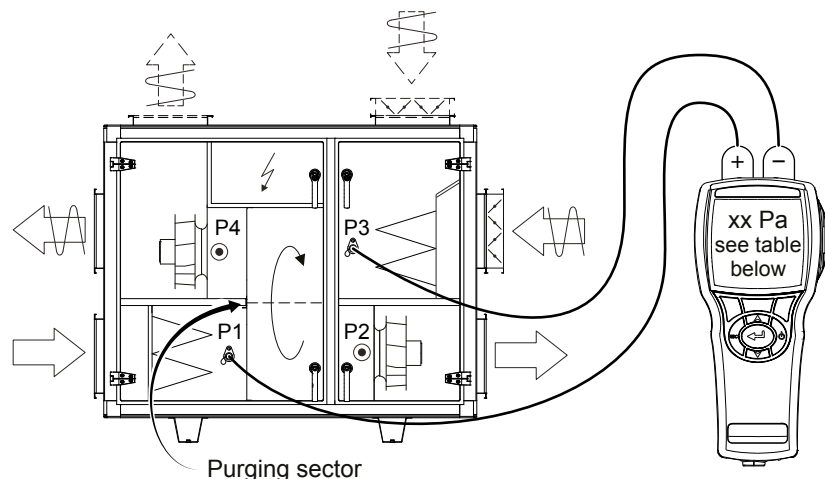

- Read the rec. setting (adjustment hole in the purging sector) from the table below.

	Rotor variant	Adjustment hole in the purging sector				
		5 open*	4	3	2	1 closed
Diff. pressure between P1 and P3 (Pa)	Normal	< 200	200 – 400	400–600	> 600	-
	Plus	< 300	300–500	500–700	> 700	-

*maximum open purge sector, preset position from the factory-
 Adjust the purging sector if the need arises. The illustration shows the purging sector set to the maximum open position.

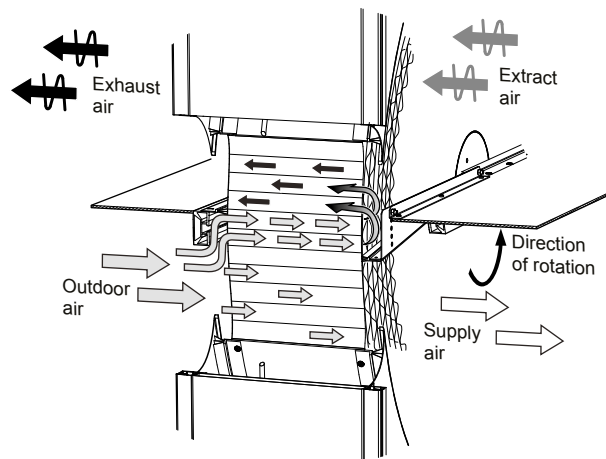

Schematic diagram - sizes and model may vary.

Cleaning

- Remove dust by carefully vacuum cleaning using a soft brush.
- In the event of stubborn and heavy-duty dirt, the rotor can be sprayed with a mild, alkaline detergent.
- Compressed air at low pressure (max. 6 bar) can be used for blowing the surfaces clean. To avoid damage, the nozzle should not be held any closer to the rotor than 5–10 mm.

A hygroscopic rotor variant can absorb particles which in some cases give off odours. To prevent odours arising, exercise run the hygroscopic rotor using the integrated control function. If an odour persists, we recommend cleaning the rotor with a mild, alkaline detergent.

Lubrication

The bearings and drive motor are permanently lubricated and do not require additional lubrication.

7.4 Air heater water (ECET-VV) and Thermoguard (ECET-TV)

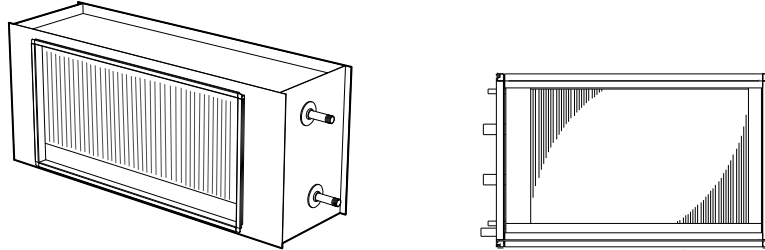

Air heater water (code ECET-VV) and Thermoguard air heater water (code ECET-TV)

The heating coil consists of a number of copper tubes with aluminium fins pressed on them. The coil will have impaired capacity if dust forms a coating on the coil surfaces. Not only does this impair the heat transfer capacity of the coil, it also increases the pressure drop on the air side.

Even if the ventilation system is fitted with high quality filters, as time passes dust deposits will form on the front edges of the coil fins (at the inlet side). To utilise its full capacity, the coil must be well vented. The pipework should be vented by opening the bleeder screws in pipe connections and/or an air vessel.

Inspection

Check:

1. The coil fins to detect possible mechanical deformity
2. That the water coil is not leaking.

Cleaning

If the fins on the batteries are dirty, clean them by vacuuming from the inlet side, or carefully blow them clean with compressed air from the outlet side. In the event of stubborn dirt, use a mild, alkaline detergent.

Bleeding

Bleed the heating coil and the pipework if needed. Bleeder screws are on top of the coil or on the tube connections.

Function

Check that the coil is radiating heat. This can be done by temporarily increasing the temperature setting (setpoint).

Additional maintenance for Thermoguard (code ECET-TV)

1. Regularly check safety valve function (at least once a year). If you see that the valve is leaking, this is normally due to impurities from the pipe system that have accumulated on the valve seat. In normal cases, it is sufficient to carefully turn the valve knob and in this way “flush” the valve seat clean. If the safety valve continues to leak, you will have to replace it with a new one of the same type and with the same opening pressure.
2. Any shut-off valves on the supply or return lines may not be closed if freezing temperatures are likely.
3. If a Thermoguard coil has frozen, let it thaw completely before restarting operation. If the heat recovery unit is installed upstream of the coil, it is often sufficient to run heat recovery to thaw the coil. If this does not work, some other external heating source will have to be used for thawing the water coil.

Important! To ensure correct Thermoguard coil function, the entire coil must be allowed to thaw before returning it to full operation. Make sure that water is circulating in the entire coil when you start it up.

7.5 Air heater electric (code ECET-EV)

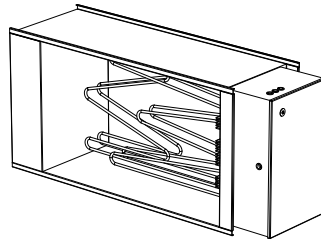

Air heater electric (code ECET-EV)

The heating coil consists of “unsheathed” electric heating rods. A substantial accumulation of dust or other impurities on the heating rods will cause them to overheat. This could shorten their service life. This might also entail an odour of burnt dust and, in the worse case, the risk of fire. Overheated electric heating rods may become deformed or loosen from their suspension fasteners and heat the air unevenly.

Inspection

Check that the electric heating rods are correctly positioned and that they are not deformed in any way.

Cleaning

Vacuum and/or wipe all surfaces with a cloth.

Function

1. Simulate reduced required output by temporarily lowering the temperature setting (setpoint), so that all the electric output steps (contactors) switch out.
2. Then sharply increase the setpoint setting and check that the electric output steps switch in.
3. Restore the temperature setting.
4. Shut down the unit via the service switch in the control equipment, safety switch in the 0 position.

NB:

The safety switch is not designed for starting/stopping the unit. Always use the service switch in the control equipment to start and shut down the unit.

4. All the electric output steps should switch out (i.e. the contactors in the OFF position). Stopping the unit may be delayed approx. 2–5 minutes to allow the fans to cool the heat energy stored in the air heater.

The electric heater is equipped with dual temperature limiters. The one that re-sets itself automatically should be set to 70°C.

The overheat protection with manual reset interrupts operation when the heater reaches approx. 120°C and is located on the cover panel on the side of the heater. **Determine the cause of overheating and take corrective action before you reset the protection device.**

Please note that the risk of overheating increases as the air flow through the unit decreases. The air speed should not be lower than 1.5 m/s.

7.6 Air cooler water (code ESET-VK) Air cooler for direct expansion (code ECET-DX)

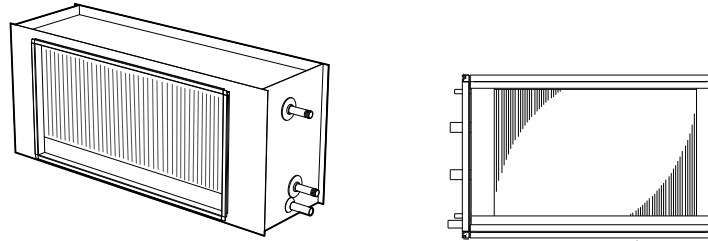

Air cooler water (code ECET-VK) and Air cooler for direct expansion (code ECET-DX)

The cooling coil consists of a number of copper tubes with aluminium fins pressed onto them. The coil will have impaired capacity if dust forms a coating on the coil surfaces.

Not only does this impair the heat transfer capacity of the coil, it also increases the pressure drop on the air side.

Even if the ventilation system is fitted with high quality filters, as time passes dust deposits will form on the front edges of the coil fins (at the inlet side). A drip tray with drain is located under the cooling coil for collecting and removing evaporation water.

Inspection

Check:

1. The coil fins to detect possible mechanical deformity
2. That the water coil is not leaking
3. That cooling energy is uniformly distributed across the coil surfaces (in operation)
4. The drip tray and drain with water trap (clean if necessary)
5. That the water trap (without non-return valve) is filled with water.

Cleaning

If the fins on the batteries are dirty, clean them by vacuuming from the inlet side, or carefully blow them clean with compressed air from the outlet side. In the event of stubborn dirt, use a mild, alkaline detergent.

Bleeding (Only applies to ECET-VK)

Bleed the cooling coil and the pipe connections if needed. Bleeder screws are on top of the coil or on the tube connections.

Function

Check that the coil is emitting cooling energy. This can be done by temporarily lowering the temperature setting (setpoint). Note that cooling is blocked when the outdoor temperature drops below the set value for cooling start. (For control equipment (code MX) Login 2000 - Main Menu/Unit/Temperature Control/Cooling/Block at outdoor temp).

7.7 Fan unit

The purpose of the fans is to transport air through the system, i.e. the fan must overcome the flow resistance in air terminals, air ducts and the unit.

The fan speed is regulated to provide correct air flow. If the fans generate a lower air flow, this will impair the function of the ventilation system.

- If the supply air flow is too low, the system will be out of balance, causing poor room climate.
- If the extract air flow is too low, the ventilation capacity will be unsatisfactory. Imbalance may also force moist air out into the building structure. One reason why the fans are generating too little air flow may be that impurities have collected on the fan impeller blades.



WARNING!

High voltage and rotating fan impeller, risk of personal injury.

Working on/servicing the unit – Shut down the unit via the service switch in the control equipment, then turn the safety switch to the 0 position and lock it.



WARNING!

Rotating fan impeller, risk of personal injury. Shut down the unit via the service switch in the control equipment, then turn the safety switch to the 0 position and lock it. Wait at least 3 minutes before opening inspection doors.

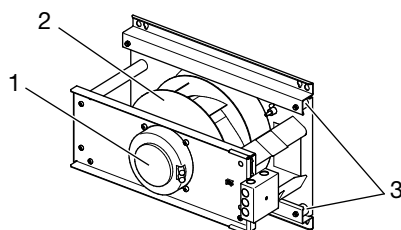

Fan unit, sizes 04 and 06

1. EC motor with control unit
2. Fan impeller
3. Anti-vibration mounting

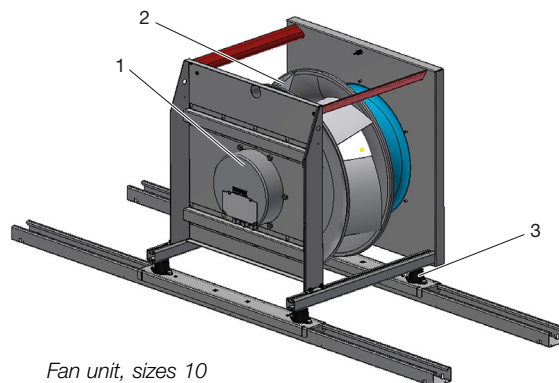

Fan unit, sizes 10 and 16

Fan - sizes 04 and 06

Inspection

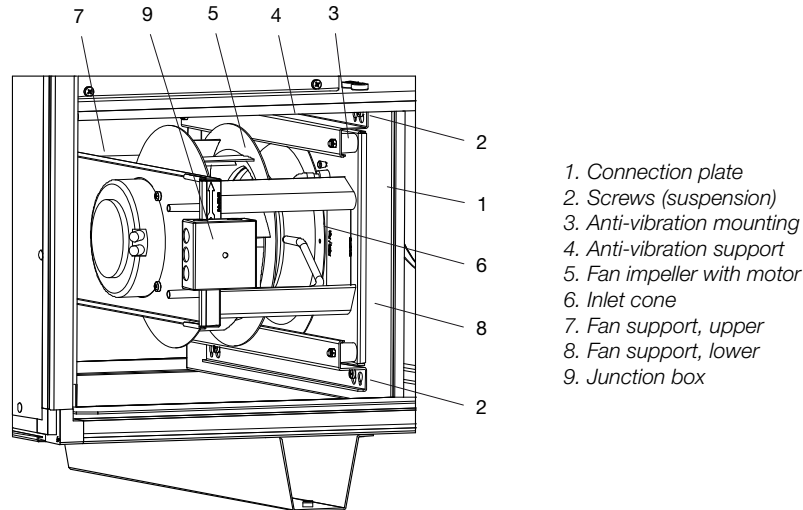

Fan unit, sizes 04 and 06

1. Remove one end of the fan assembly's earth braid. Remove the screws (position 2) in the connection plate (position 1) and unhook the fan unit from the keyholes in the anti-vibration supports (position 4), both upper and lower.
2. Check that the fan impeller with motor (position 5) rotates easily, is in balance and does not vibrate. Also check that the fan impeller is clean from any accumulation of particles. Imbalance may be due to a coating or damage to the fan impeller blades.
3. Listen to the sound from the motor bearings. If the bearings are in good condition, you will hear a slight purring sound. A scraping or pounding sound may mean that the bearings are damaged and service is then required.
4. Check that the fan impeller with motor (position 5) is firmly mounted in the upper fan support (position 7) and that it has not shifted sideways toward the inlet cone (position 6). Also check to make sure that the inlet cone is properly secured.
5. The fan unit is mounted on the connection plate by means of rubber anti-vibration mountings (position 3) between the lower fan support (position 8) and the anti-vibration supports (position 4). Check that the anti-vibration mountings are intact and are firmly fitted.
6. Check that the gasket on the connection plate (position 1) around the connection opening is intact and is firmly fitted.
7. Check that the measurement tubes are securely fitted on each measurement outlet.
8. Check that the edge protection on the upper fan support (position 7) is firmly mounted and protects the cables that are wired to the junction box (position 9).

9. Reinstall the fan unit by hooking in on the key holes in the anti-vibration supports (position 4), both upper and lower, and secure the screws (position 2) in the connection plate (position 1)
10. Check the air flows by measuring Δp in the connections for flow measurement. Use the unit's air flow label and see which flow corresponds to the measured Δp .

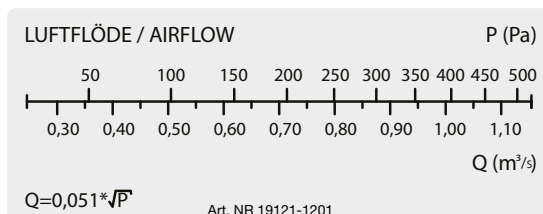

Example of air flow label

Cleaning

1. Follow item 1 under *Inspection*.
2. Wipe the fan impeller blades to remove any coatings. Use a mild, alkaline detergent.
3. The external surfaces of the motor must be kept clean. Remove any dust, dirt and oil. Clean with a dry cloth. In the event of stubborn dirt, use a mild alkaline detergent. The motor is likely to overheat inside if thick layers of dirt prevent air from entering the motor to cool the stator structure.
4. Vacuum clean inside the unit so that particles will not be blown out into the duct system.
5. Clean the other parts in the same way as the fan impeller. Check that the inlet cones are securely mounted.
6. Follow item 9 under *Inspection*.

Fan - sizes 10 and 16

Inspection

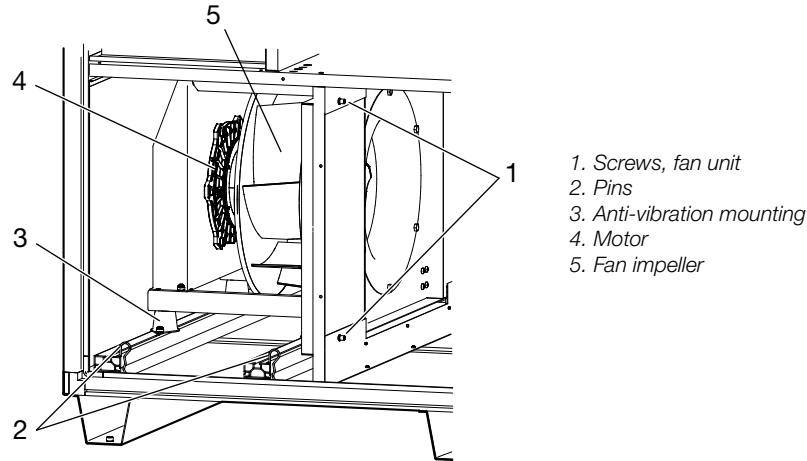

Fan unit, sizes 10 and 16

1. Remove one end of the fan assembly's earth braid. Remove the screws (position 1) and the pins (position 2). Pull out the fan units (fan and motor are mounted on slide rails).
2. Check that the fan impeller rotates easily, is in balance and does not vibrate. Also check that the fan impeller is clean from any accumulation of particles. Imbalance may be due to a coating or damage to the fan impeller blades.
3. Listen to the sound from the motor bearings. If the bearings are in good condition, you will hear a slight purring sound. A scraping or pounding sound may mean that the bearings are damaged and service is then required.
4. The fan impeller and motor are mounted on a support fitted with rubber anti-vibration mountings. Check that the anti-vibration mountings are securely mounted and are intact.
5. Check the mounting bolts as well as the suspension devices and support.
6. Check that the gasket on the connection plate around the connection opening is intact and is firmly fitted.
7. Check that the measurement tubes are securely fitted on each measurement outlet.
8. Remount the fan units.
9. Check the air flows by measuring Δp in the connections for flow measurement. Use the unit's air flow label and see which flow corresponds to the measured Δp .

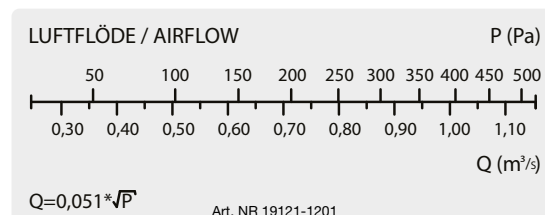

Example of air flow label

Cleaning

1. Follow items 1-7 under *Inspection*.
2. Wipe the fan impeller blades to remove any coatings. Use a mild, alkaline detergent.
3. The external surfaces of the motor must be kept clean from dust, dirt and oil. Clean with a dry cloth. In the event of stubborn dirt, use a mild alkaline detergent. The motor is likely to overheat inside if thick layers of dirt prevent air from entering the motor to cool the stator structure.
4. Vacuum clean the air handling unit so that particles will not be blown out into the duct system.
5. Clean the other parts in the same way as the fan impellers. Check that the inlet cones are securely mounted.
6. Remount the fan units.

7.8 Damper (code ECET-UM, ECET-TR)

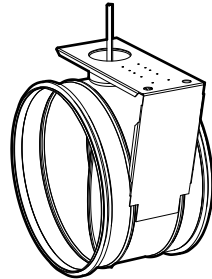

Size 04

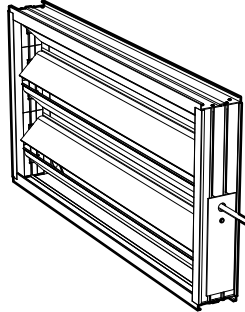

Sizes 06, 10 and 16

The purpose of the dampers is to regulate the air flow. Faulty function gives rise to disturbances that may result in serious problems.

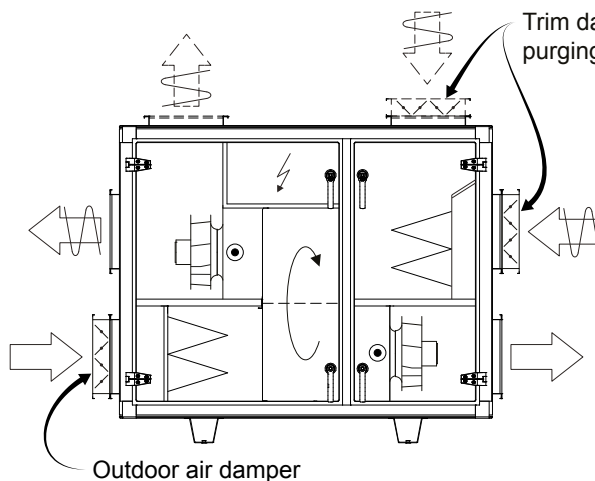

- If the outdoor air damper does not:
 - Open completely this reduces the air flow
 - Close completely when the unit stops, the heating coil is likely to freeze
 - Seal properly (leaks) this will result in increased energy use.
- If the trim damper for the rotor purging function is not working or is not correctly adjusted, possible odours in the extract air are likely to be transferred via the rotor to the supply air. Units that are supplied with integrated control equipment are equipped with the pressure-controlled rotor purging function control function in order to optimise the trim damper function and minimise the risk of transferring odour.

Inspection

1. Check the function of the damper actuator.
2. Check the dampers for tightness when they are closed. If they are not sealed, adjust the damper actuator to make the dampers tight (does not apply to trim dampers).
3. Check the sealing strips.
4. If the damper is not working, check that there are no screws penetrating the drive mechanism/damper blades to interfere with damper function.

Cleaning

Clean the damper blades with a cloth. In the event of stubborn dirt, use a mild, alkaline detergent.

7.9 Sound attenuator (code ECET-LD)

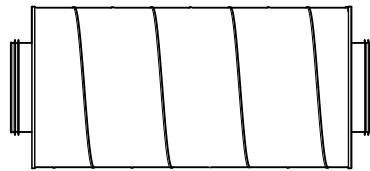

Size 04

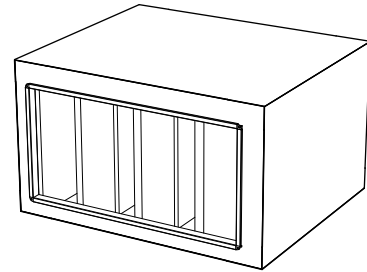

Sizes 06, 10 and 16

The purpose of the sound attenuator is to reduce the sound power level in the system.

Inspection

Check that the baffle elements are intact and have clean surfaces. Take action if necessary.

Cleaning

Vacuum and/or wipe all surfaces with a damp cloth. In the event of stubborn dirt, use a mild, alkaline detergent.

7.10 StarCooler cooling unit (code ACEC)

General

The cooling unit has been designed and fabricated along given operation parameters that must be met in order for the unit to operate optimally and provide good operating economy. The operation parameters must not be changed unless a check is first made to ascertain that the changes will be within the unit's operating range.

Leakage inspection and registration

For information on the operator's responsibility with regards to leakage inspection and registration, see "2.6 Handling of refrigerant" page 5.

Visual check

Check:

1. The fins on the condenser and evaporator to detect mechanical deformations
2. The drip tray and drain with water trap (clean if necessary)
3. That the water trap (without non-return valve) is filled with water.

Cleaning

If the fins on the batteries are dirty, clean them by vacuuming from the inlet side, or carefully blow them clean with compressed air from the outlet side. In the event of stubborn dirt, use a mild, alkaline detergent.

Function

Check that the cooling unit operates as it should by temporarily lowering the temperature setting (setpoint). Note that cooling is blocked during weak air flow or when the outdoor temperature drops below the set value for cooling start. (Login 2000 - Main Menu/Unit/Temperature Control/Cooling/Block at outdoor temp).

8 Troubleshooting

8.1 StarCooler cooling unit (code ACEC)

Troubleshooting via symptoms

Symptom	Possible cause	Corrective action
Low cooling power – too high temperature in the cooled object/medium	The power supply has been interrupted	Check the control/safety switches and fuses
	None or too low air flow across evaporator	Check that nothing inhibits the air flow
	The thermostat/control equipment is incorrectly set/defective	Adjust the settings or replace the equipment
	The capacity controller is set for too-high initial pressure	Turn the opening screw anti-clockwise 1/6 turn at a time; read the temperature change after 5 minutes, and so forth. See the figure below.
	Compressor is not operating	See symptom “Compressor is not operating”
Compressor is not operating	The power supply has been interrupted	Check the control/safety switches and fuses
	Compressor has opened a safety circuit	Check and reset, if needed
	Defective compressor	Check/replace
The low pressure control switches out the compressor	Insufficient refrigerant volume	The cooling system has a leak. Find the leak and seal it. Add more refrigerant.
	No or too low air flow across the evaporator	Check the air flow
	Expansion valve is defective	Check/replace
	The low pressure control is defective	Check/replace
The high pressure switch switches out the compressor	No or too low air flow across the condenser	Check the air flow across the condenser. Make sure that the external fire damper exercise cycle interlocks the unit (if selected)
	The high pressure switch is defective	Inspect, replace
Frost on the evaporator	The expansion valve is incorrectly preset/defective	Check/replace
	Insufficient refrigerant volume	Look for leakage, seal the leak and top up with refrigerant
	Low supply air flow	Adjust the air flow



Air handling with focus on LCC

You are welcome to contact us

Switchboard:	+ 46 (0)47 075 88 00	
Control support:	+46 (0)47 075 89 00	styr@ivprodukt.se
Service:	+46 (0)47 075 89 99	service@ivprodukt.se
Spare parts:	+46 (0)47 075 88 00	order@ivprodukt.se
Visit our website:	www.ivprodukt.com	
Documentation for your unit:	docs.ivprodukt.com	
Technical documentation:	docs@ivprodukt.se	