



Assembly instructions

EcoHeater

Size 060-300





Documentation for your unit

1. Go to IV Produkt's order portal, docs.ivprodukt.com or scan the QR code.
2. Enter your order number.
3. Press ENTER or click search.
4. Select your order.

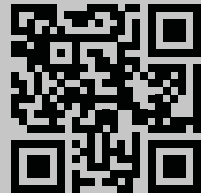

Is documentation missing?

See information in section

"2.1 Documentation and support", page 10.

TABLE OF CONTENTS

| | | |
|----------|--|-----------|
| 1 | SAFETY | 5 |
| 1.1 | Intended application | 5 |
| 1.2 | Unintended use | 5 |
| 1.3 | General safety | 5 |
| 1.4 | Structure of warning messages | 6 |
| 1.5 | General warning messages | 6 |
| 1.6 | Signs | 8 |
| 1.6.1 | Type plate | 8 |
| 1.7 | Product liability | 8 |
| 1.8 | Lifting unit, functional parts | 9 |
| 1.9 | After the product's lifetime | 9 |
| 2 | GENERAL INFORMATION | 10 |
| 2.1 | Documentation and support | 10 |
| 2.2 | Informational message, not safety-related | 10 |
| 2.3 | Spare parts | 10 |
| 2.4 | Symbols on drawings and in manual | 11 |
| 3 | DESCRIPTION OF UNIT | 12 |
| 3.1 | Unit version | 12 |
| 3.2 | Orientation of the unit sides/parts | 12 |
| 4 | DELIVERY RECEIPT / STOCKHOLDING | 13 |
| 4.1 | Receive, unpack | 13 |
| 4.2 | Packaging and protection | 13 |
| 4.3 | Recommended storage | 13 |
| 5 | LIFTING UNIT | 14 |
| 5.1 | Lift with forklift | 14 |
| 5.2 | Lifting brackets, pre-assembled lifting eyes, spreader bars | 15 |
| 5.3 | Lift with bracket EMMT-08, for 50-profile | 16 |
| 5.4 | Lifting unit pre-assembled on beam frame | 17 |
| 6 | PREPARE FOR ASSEMBLY | 18 |
| 6.1 | Create service area, electrical safety distance | 18 |
| 6.2 | Preparation for outdoor version | 19 |
| 6.3 | Floor installation | 20 |
| 6.4 | Adjustable feet for vibration damping (accessory) | 21 |
| 6.4.1 | Adjustable foot with steel spring damper (accessory) - EHPT-05 | 21 |
| 6.4.2 | Sylodyn foot with Sylodyn mat (accessory) - AMMT-01 | 22 |

Assembly instructions

EcoHeater

| | | |
|-----------|--|-----------|
| 7 | ASSEMBLE | 23 |
| 7.1 | Tools for assembly | 23 |
| 7.2 | Assemble, step by step | 23 |
| 7.3 | Adjusting the unit feet | 24 |
| 7.3.1 | Adjustable feet on bottom beam | 24 |
| 7.3.2 | Adjustable feet on other variants | 24 |
| 7.4 | Assemble weather hood outdoors (optional) | 24 |
| 7.5 | Install sealing strip | 25 |
| 7.5.1 | Sealing strip for outdoor use..... | 25 |
| 7.6 | Connect parts..... | 26 |
| 7.6.1 | Join with screw connections..... | 26 |
| 7.6.2 | Join with guide pins | 26 |
| 7.7 | Quick connectors..... | 27 |
| 7.7.1 | Quick connector, signal input | 27 |
| 7.7.2 | Quick connector, power supply | 27 |
| 7.8 | Assemble cover detail at joint | 27 |
| 8 | CONNECT PIPE SYSTEM AND WATER LOCK | 28 |
| 8.1 | Schematic diagram, recommended connection..... | 28 |
| 8.2 | Connection of liquid side | 29 |
| 8.3 | Water trap | 30 |
| 8.3.1 | Connect water trap | 30 |
| 9 | CONNECT POWER SUPPLY AND COMMUNICATION | 31 |
| 9.1 | Connection | 31 |
| 9.2 | Recommended fuse and power supply | 31 |
| 10 | DUCT ACCESSORIES | 32 |
| 10.1 | Connection to rectangular duct..... | 32 |
| 10.2 | Connect the fabric sleeve (accessory)..... | 33 |
| 10.3 | Install sound attenuator (EMT-02) | 33 |
| 10.4 | Install shut-off damper (EMT-01) | 33 |
| 10.5 | Fire bypass section with internal damper (EHP-B) | 33 |
| 10.6 | Install Weather hood smoke back (EHPT-08) | 33 |
| 11 | AFTER ASSEMBLY | 34 |
| 11.1 | Post-inspection and maintenance..... | 34 |

1 SAFETY

This section addresses important safety aspects during assembly, with the aim of increasing safety awareness and avoiding injury to people or damage to the environment and the unit.



- This manual contains important instructions. Read it carefully and follow the instructions.
- Pay special attention to warning and information messages, as well as markings on the product.
- Keep the manual for future use.

00177

1.1 Intended application

Intended use

Exhaust air heat pump is intended to be used for energy recovery from exhaust air in apartment buildings.

Intended user

The contents of this manual are intended for personnel who install the unit on site.

Intended installation environment

- The unit is placed indoors, outdoors (outdoor version) or in an attic.
- When installed indoors, the unit should be placed in a ventilated space that maintains a temperature of +7 – +30 °C and, during winter, a humidity level of < 3.5 g/kg dry air.

1.2 Unintended use

Any use other than that specified in Intended Application is prohibited unless specifically permitted by IV Produkt. The unit is not permitted to be used or installed in an explosive environment.

1.3 General safety

Failure to follow the safety instructions may result in personal injury or damage to the air handling unit. To avoid injury to persons, or damage to surroundings or equipment:

- Follow national and local laws/regulations for safe work, e.g. fall protection when working at height.
- Do not wear loose-fitting clothing or jewellery that could get caught.
- Do not step or climb on the unit.
- Use appropriate tools.
- Use appropriate personal protective equipment.
- Observe the unit's markings; product labels, information and warning stickers.

Personal protective equipment

Personal protective equipment should always be used based on the risks that occur in the workplace. For example, use safety shoes with steel toecaps, hearing protection, a hard hat, gloves, safety glasses, covering clothing, protective overalls, a face mask/protective mask and/or fall protection where the work and work environment require it.



Assembly instructions EcoHeater

1.4 Structure of warning messages

Warning messages in the instructions warn of risks when handling and assembling the product. Carefully follow the instructions in the warning messages.



The warning symbol  indicates that a risk exists.

WARNING! indicates a potential hazard which, if not avoided, could result in death or serious injury.

CAUTION! indicates a potential hazard which, if not avoided, could result in **material damage** to the product or its surroundings, as well as impaired product function.

"**Risk for xxxxxx.**" indicates the risk in a short risk title.

Descriptions in italics provide more detailed information about what the risk entails.

- The points indicate how the user can avoid harm.

1.5 General warning messages



WARNING!

Risk of life-threatening or serious personal injury.

Electrical voltage can cause electric shock, burns and death. The product must not be energised during assembly.

- Electrical connection and electrical work may only be carried out by a qualified electrician.
- For initial start-up of the unit, see Operation and Maintenance of the unit on IV Produkt's Order portal.

00176



WARNING!

Risk of life-threatening or serious crushing or compression injury.

The unit parts are often heavy and cannot be lifted by hand. See weights indicated on the layout drawing.

- Follow the lifting and assembly instructions in this manual.
- Use lifting equipment where available.
- Use appropriate protective equipment.

00179



WARNING!

Risk of serious crushing injury.

A falling unit when lifting can cause crushing injuries.

- Follow the instructions for lifting in this manual.
- Never exceed the specified weight for the respective lifting method or lifting equipment.
- Slide stops must be fitted when lifting, if bracket is used.

00180-1



WARNING!

Risk of cutting.

Sharp edges can cause cuts.

- Use appropriate personal protective equipment when the work requires it.

00181

CAUTION!

Risk of environmental impact.



Depending on the business at which the unit is in operation, the extract air may contain environmentally harmful substances that can condense into drains from the unit.

- Ensure compliance with applicable national and international environmental regulations.

00380

WARNING!

Risk of personal injury.



Contact with the oil can cause skin irritations.

- Draining oil from the compressor must only be carried out by certified persons in accordance with applicable EU regulations for refrigerants.
- Wear appropriate protective clothing.
- Wash hands and other body parts that have been in contact with the oil.

00330

WARNING!

Risk of serious personal injury.



Contact with refrigerants can cause frostbite to the skin.

- Refrigerants and parts containing refrigerants may only be handled by persons with certificates in accordance with current EU regulations for refrigerants.
- Wear appropriate protective clothing.

00331

WARNING!

Risk of fire in case of refrigerant leak.

A2L refrigerants are mildly flammable and can ignite in the event of a leak.



- In the event of suspected refrigerant leak or external damage to the refrigerant circuit has led to refrigerant leak:
 - Clear the ventilation room
 - Ensure good ventilation
 - Call for certified refrigeration technician.
- Service of cooling units/reversible heat pumps/exhaust air heat pumps may only be carried out by a certified refrigeration technician. In the event of repairs/service:
 - Shut down the unit at the service switch in the control equipment, then turn the safety switch to 0 position and lock. Note that there may be different safety switches for the different parts of the unit. All safety switches should be switched off and locked before repairs/service.
- Due to the risk of sparks, safety switches must not be used if there is a suspected refrigerant leak.
- Where detector system installed:
 - Make sure that the detector system is not disabled.
 - Make sure that external dampers in the ductwork do not block the unit's air flow, such as through uncontrolled closing.

00352



Assembly instructions

EcoHeater

1.6 Signs

Keep signs and decals clean from dirt. Replace missing, damaged or illegible signs and decals on the machine. Contact IV Produkt for replacement decals, specify the part number.

1.6.1 Type plate

Exhaust air heat pump is provided with type plates placed on the access side. The type plate is used, among other things, to identify the product.

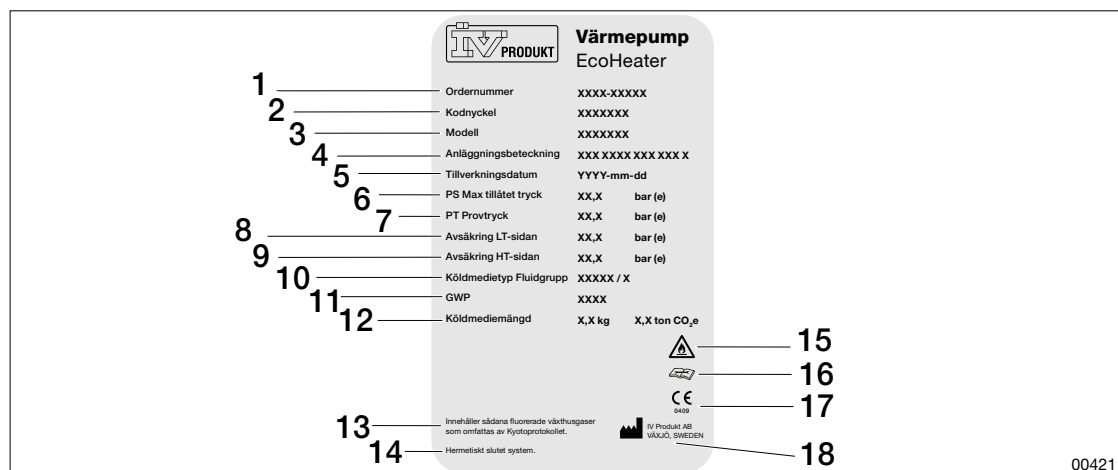

Figure: Example image: Unit type plate

- | | |
|----------------------------------|--|
| 1. Order number | 11. GWP |
| 2. Code key | 12. Refrigerant quantity |
| 3. Model | 13. Contains fluorinated greenhouse gases covered by the Kyoto Protocol. |
| 4. Facility designation | 14. Hermetically sealed system. |
| 5. Date of manufacture | 15. Fire hazard |
| 6. PS Max allowable pressure | 16. Read service manual |
| 7. PT Test pressure | 17. CE marking (including Notified Body) |
| 8. Circuit protection LP side | 18. Manufacturer |
| 9. Circuit protection HP side | |
| 10. Refrigerant type Fluid group | |

1.7 Product liability



CE marking (EU)

Exhaust air heat pump is CE marked and meets applicable requirements according to specified directives and standards in the Declaration of Conformity. The marking covers the unit in the version in which it was delivered and provided that it has been assembled and put into operation according to IV Produkt's instructions. This does not cover units that have been modified, components that have been added later, or other systems in which the unit may be included. The unit may not be put into use until the system in which it is part complies with the requirements for CE marking.

The Declaration of Conformity can be downloaded from IV Produkt's order portal, "[2.1 Documentation and support](#)", page 10.

Manufacturer

The air handling unit is manufactured by IV Produkt AB, Sjöuddevägen 7, S-350 43 VÄXJÖ.

Warranty

For proper function and for the warranty to apply, the assembly instructions must be followed.

Extended warranty

Extended warranty is additional to the order and in order to claim the extended warranty (5 years) a complete documented and signed IV Produkt Service and Warranty Book must be presented, according to ABM 07 with supplement ABM-V 07 or according to NL 17 with supplement VU 20.

Disclaimer

Ongoing product development may result in changes without prior notice.

1.8 Lifting unit, functional parts

Lifting should be carried out according to the lifting instructions in this document, "[5 LIFTING UNIT](#)", [page 14](#) and following markings and signs on the unit. If there are no lifting instructions or markings, lifting must be carried out according to lifting methods developed by the transport industry.

1.9 After the product's lifetime

For dismantling and decommissioning of the unit, see Operation and maintenance.



Assembly instructions EcoHeater

2 GENERAL INFORMATION

2.1 Documentation and support

The documentation for your unit is available at IV Produkt's order portal. See "[2.1 Documentation and support](#)", page 10.

It may take up to two weeks before all documentation is available on IV Produkt's order portal. The text "Documentation in development" is displayed until the documentation is complete. If documentation is missing or incorrect, please contact DU/Documentation. For other support, contact the department to which the matter applies. See contact information on the back of the manual.

2.2 Informational message, not safety-related



Symbol together with information text highlights difficulties and also gives tips and recommendations.

00182

2.3 Spare parts

Spare parts list is available at IV Produkt's order portal. Order spare parts and accessories from IV Produkt. See contact information on the back of the manual. Please state the order number and unit designation from the type plate, located on the unit.

2.4 Symbols on drawings and in manual

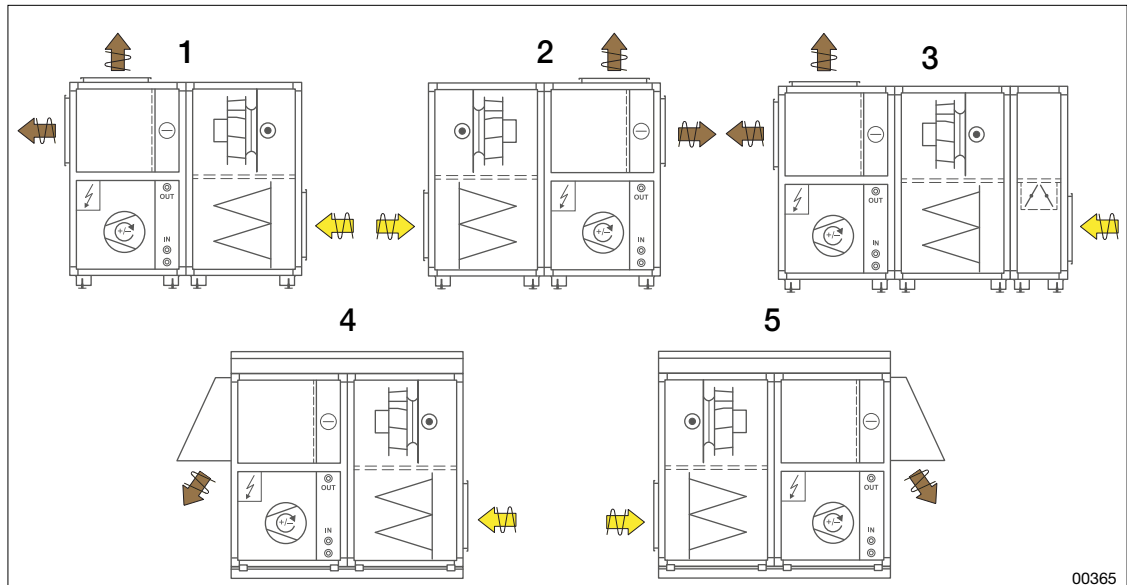
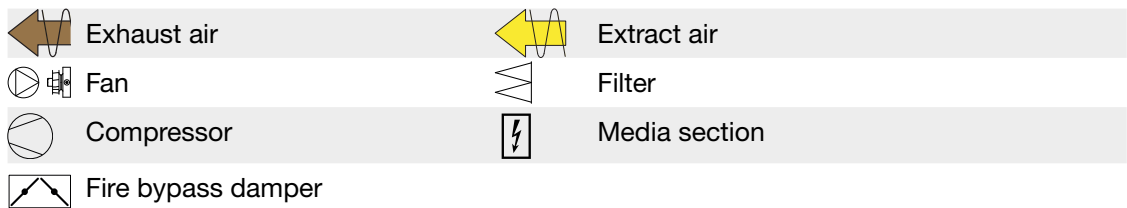

Figure: Example installation drawing

- | | |
|---------------------------------------|----------------------------|
| 1. EcoHeater Indoor left | 4. EcoHeater Outdoor left |
| 2. EcoHeater Indoor right | 5. EcoHeater Outdoor right |
| 3. EcoHeater Indoor left, fire bypass | |





Assembly instructions EcoHeater

3 DESCRIPTION OF UNIT

3.1 Unit version

The unit is delivered with control and regulation equipment.

The EcoHeater exhaust air heat pump consists of a fan section and a compressor section, as well as a possible smoke bypass.

Exhaust air heat pumps delivery version:

- block on support legs with adjustable feet.
- block on bottom beam with support legs with adjustable feet.
- Block with beam support for outdoor use with a fixed height of 100 mm. The support cannot be supplemented with legs or adjustable feet.
- (accessory) block on bottom beam with support legs with steel spring damping.

Adjustable feet are adjustable to different heights.

Exhaust air heat pumpThe frame consists of aluminium profiles, 50 x 50 mm.

3.2 Orientation of the unit sides/parts

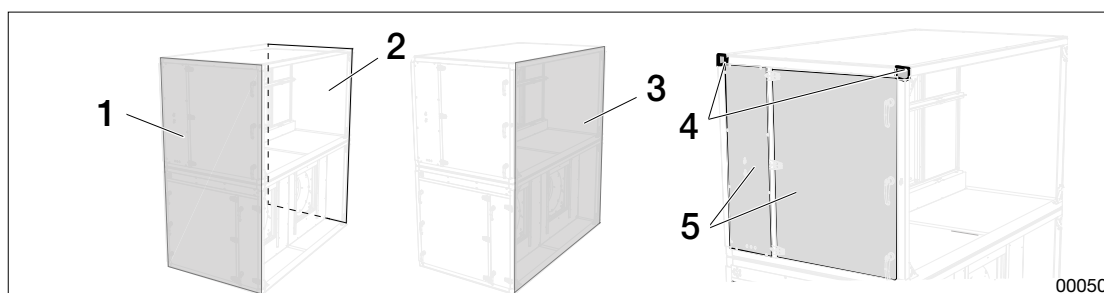

Figure: Parts of the unit

- | | |
|----------------|-----------------------------------|
| 1. Access side | 4. Assemble cover detail on joint |
| 2. Back | 5. Covers |
| 3. Gable side | |

4 DELIVERY RECEIPT / STOCKHOLDING

4.1 Receive, unpack

Upon receipt, check the goods and their packaging. Make sure there is no damage.

4.2 Packaging and protection

The product's packaging is intended to protect the product from rain and dirt during transport and storage.

The product should be stored in its original packaging for as long as appropriate. If the packaging is removed, the product must be protected so that particles (such as dust and dirt) or water do not enter the functional parts.

If the goods are dirty upon arrival, rinse the unit with water and, if necessary, clean according to the instructions for the unit surfaces in "[11 AFTER ASSEMBLY](#)", [page 34](#).

4.3 Recommended storage

Before assembly, the product should be stored on a flat surface, preferably dry and warm.

If the product is stored outdoors, it must be protected from weather conditions such as rain, snow and direct sunlight. Ventilation inside the unit parts must be secured during storage. The product can withstand storage in both heat and cold, temperature range -40 °C to +50 °C.



Small amounts of condensate, which occur during storage in changing temperatures, will dry up when the unit is put into operation, but make sure:

- good air circulation between packaging and unit and inside functional parts. Open the packaging to let in air if necessary.
- that the product is protected against extreme temperatures and weather conditions.
- that the product is protected against water penetration so that large amounts of stagnant water do not collect inside the unit.



Assembly instructions EcoHeater

5 LIFTING UNIT



WARNING!
Risk of life-threatening or serious crushing or compression injury.
The unit parts are often heavy and cannot be lifted by hand. See weights indicated on the layout drawing.

- Follow the lifting and assembly instructions in this manual.
- Use lifting equipment where available.
- Use appropriate protective equipment.

00179



WARNING!
Risk of serious crushing injury.
A falling unit when lifting can cause crushing injuries.

- Follow the instructions for lifting in this manual.
- Never exceed the specified weight for the respective lifting method or lifting equipment.
- Slide stops must be fitted when lifting, if bracket is used.

00180-1



CAUTION!
Risk of damage to the product
Chains/straps that are lying against the unit when lifting may damage the unit.

- Use spreader bars when lifting with bracket.
- Follow instructions for working with spreader bars.

00186

5.1 Lift with forklift



When lifting with a forklift, the lifting forks must be as long as the unit packaging or longer.

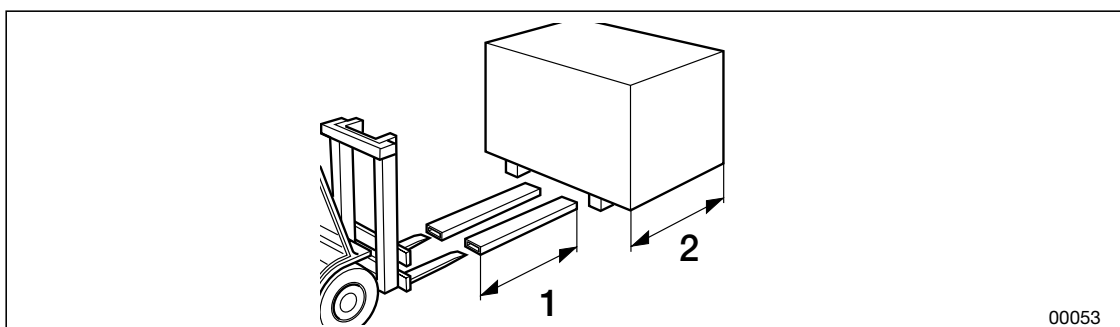

Figure: Lift with forklift

1. Fork length

2. Aggregate packaging

5.2 Lifting brackets, pre-assembled lifting eyes, spreader bars

Outdoor version: Lifting eyes are mounted on the front and back.



- Maximum angle of the lifting hook is 80°
- The maximum tilt of unit parts when lifting is 15°. If the tilt is greater than 15°, the chains/straps should be shortened or extended until the angle is less than 15°.
- The spreader bar should be 100–400 mm wider than the unit.
- If lifting eyes are pre-mounted on the unit, these should be used when lifting.

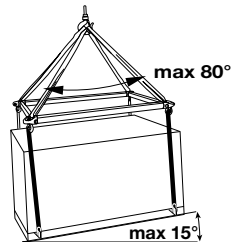

00360

Figure: Example image of lifting with spreader bar and tilt



Assembly instructions EcoHeater

5.3 Lift with bracket EMMT-08, for 50-profile



WARNING!

Risk of serious crushing injury.

A falling unit when lifting can cause crushing injuries.

- Follow the instructions for lifting in this manual.
- Never exceed the specified weight for the respective lifting method or lifting equipment.
- Slide stops must be fitted when lifting, if bracket is used.

00180-1



- EMMT-08 are delivered in sets of four. Load per lifting bracket ≤ 400 kg.
- Load if all four brackets are used ≤ 1600 kg.
- A safety factor of 1.6 has been practiced in static testing of lifting brackets.
- Use a shackle with a safety factor of 6:1.
- The bracket must not be mounted downwards or sideways.
- Lifting brackets must not be mounted in the middle profile of two-level sections.

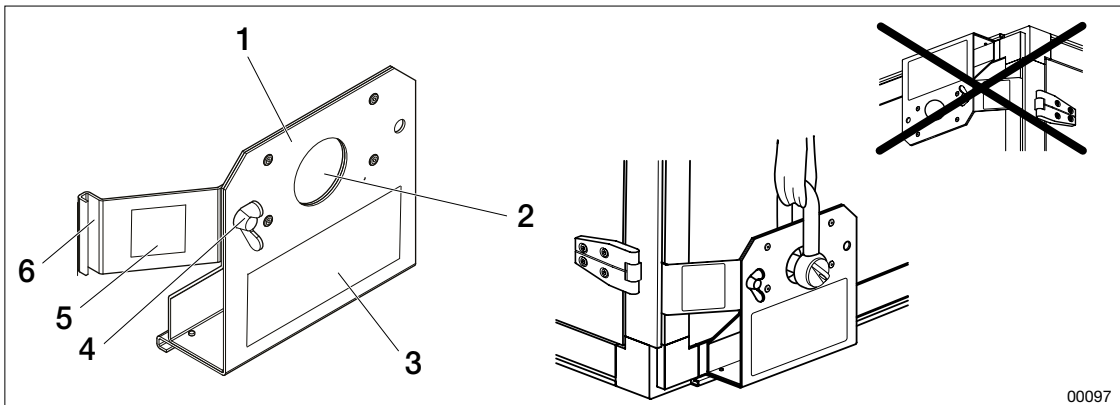

00097

Figure: Lifting bracket EMMT-08

- | | |
|----------------------------|--------------------|
| 1. Lifting bracket EMMT-08 | 4. Wing nut |
| 2. Lifting eye | 5. Decal slip stop |
| 3. Lift stop sticker | 6. Slip stop |

1. Place the lifting brackets in the lower four corners of the unit or unit section (on the longest sides of the section), with the lifting eye facing up.
2. Slide the brackets into the horizontal groove in the unit's aluminium profile.
3. Slide the slip stop into the vertical groove in the unit's aluminium profile.
4. Lock by tightening the wing nut.
5. Turn the T-bolts, with a tightening torque of 24 Nm, so that they are at 90° to the profile groove and are firmly secured under the edges of the groove.

5.4 Lifting unit pre-assembled on beam frame



WARNING!

Risk of serious crushing injury.

A falling unit when lifting can cause crushing injuries.

- Follow the instructions for lifting in this manual.
- Never exceed the specified weight for the respective lifting method or lifting equipment.
- Never remove or move the factory-fitted lifting lugs.
- Use shackle with safety factor 6:1.
- Lifting straps must not be pulled through the lifting lugs.

00192



Aluminium beam H=100 mm:

- Maximum load=750 kg/lifting eye. Total load=3000 kg (all four lifting eyes).

Aluminium beam H=160 mm:

- Maximum load=1350 kg/lifting eye. Total load=5400 kg (all four lifting eyes).
- Note that when the straps are pulled through the lifting eyes, they will lie over the hood of the EcoHeater for outdoor assembly when lifting.

1. Fit a shackle in each of the pre-assembled lifting eyes.
2. Pull straps through each shackle.
3. Lift with suitable lifting equipment.

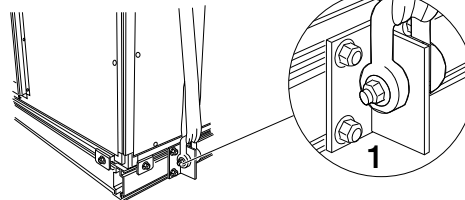

00100

Figure: Lifting eye pre-mounted on beam frame

1. Lifting eye with shackle (four pieces)



Assembly instructions EcoHeater

6 PREPARE FOR ASSEMBLY



When installed, the unit must be horizontal at the longitudinal front edge to ensure correct drainage of condensate.

Duct systems should be designed and installed so that drainage cannot back up into the unit. Water traps are installed where indicated. See "[8 CONNECT PIPE SYSTEM AND WATER LOCK](#)", page 28.

6.1 Create service area, electrical safety distance



- The service area in front of the unit should be approximately 1.5 x the depth of the unit to enable service, replacement of parts and cleaning.
- Follow the recommendations of the Swedish Electrical Safety Board regarding the operating space that should be available in front of electrical switching equipment.

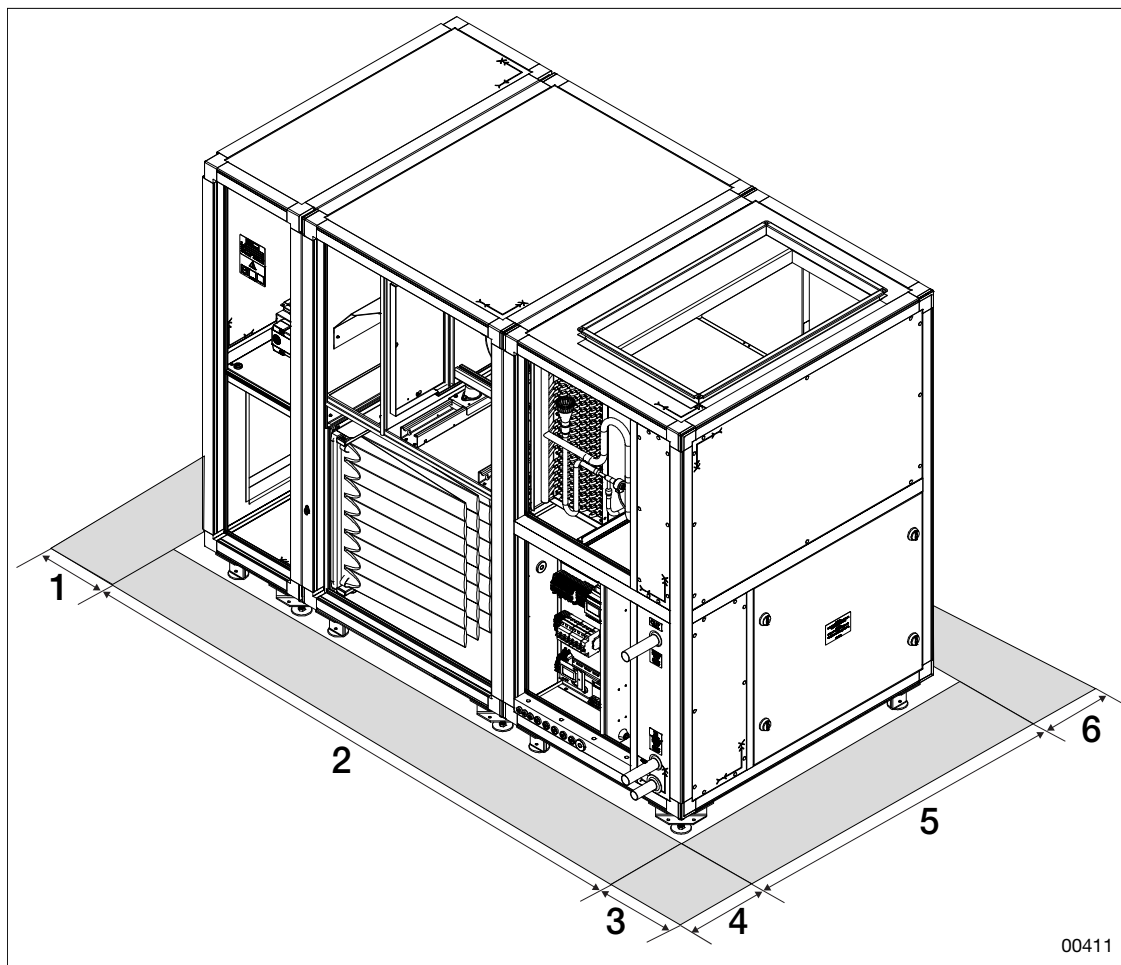

Figure: Service area (grey), right-hand version. Mirrored on the left side.

1. Gable - min 300 mm.
2. Width of the unit (B).
3. Gable, in front of compressor door - min 300 mm.
Recommended distance - 500 mm.
4. In front of the access side, 1.5 x D (min 1200 mm).
5. Depth of the unit (D).
6. Behind - min 300 mm.

6.2 Preparation for outdoor version

For outdoor units, the unit is placed on longitudinal beams on top of a waterproof roof. Water ingress can occur between beams and unit parts.



- Underlying beams (e.g. H- or U-profile) or anchor plates are not provided by IV Produkt.
- For sealing strip for outdoor use, see "[7.5.1 Sealing strip for outdoor use](#)", page 25.

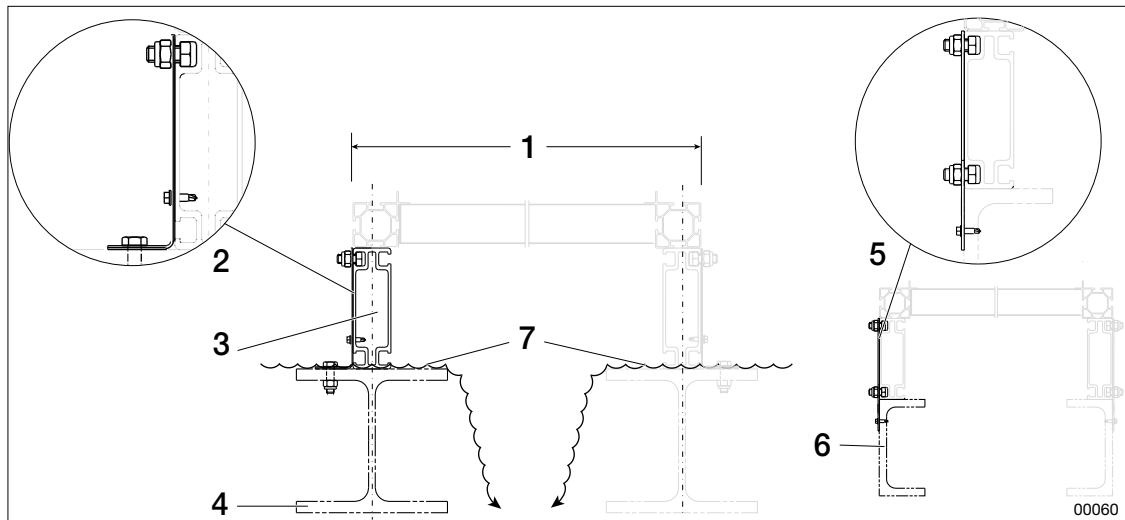

Figure: Aluminium profiles (support) and beam frames in cross-section, seen from the gable side

- | | |
|--|--|
| 1. Unit width | 5. Example, anchor plate on U-profile (not included in delivery) |
| 2. Example, anchor plate on H-profile (not included in delivery) | 6. U-profile (not included in delivery) |
| 3. The unit's aluminium beam frame | 7. Risk of water intake |
| 4. H-profile (not included in delivery) | |

The height of the aluminium beam frames is 100 mm or 160 mm and the width is 50 mm.

Air handling units on the underlying beam frame should be dimensioned as a spread load.

Air handling units on an aluminium beam frame are self-supporting between the access side and the back and only need support under the longitudinal beam on the access side and on the back. The framework should be placed with the profile centred over the H-beam. See previous picture.

Anchoring of the beam frame to underlying beams (substrate) is carried out with anchor plates according to the example in the previous image. Anchoring plates are not included in the delivery and are installed by the customer.

When delivering units in a split outdoor version, also see order-specific drawings, on IV Produkt's order portal.

Externally mounted dampers including damper actuators must be protected from the weather if the unit is not supplied with a protective intake or extractor hood.

Connecting smoke bypass ducts and smoke bypass dampers must be weather-protected and insulated in their entirety if there is a risk of condensate forming in the duct or on the smoke bypass damper.



Assembly instructions EcoHeater

6.3 Floor installation

The unit should be placed on a vibration-free, horizontal and flat surface, preferably a so-called floating floor. It is worthwhile to build a waterproof trough with a water drain on the floating floor to drain condensate.

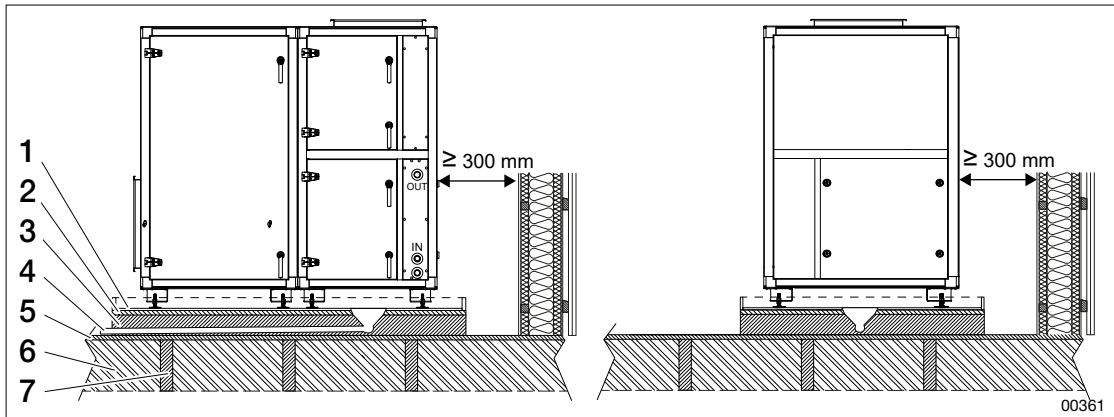

Figure: Example of floating floor with good vibration damping

- | | |
|--|--|
| 1. Waterproof trough with water drainage | 5. Floorboard |
| 2. Chipboard 22 mm or equivalent | 6. Insulation of joists |
| 3. Rock wool 100 mm | 7. Joists. When placed above a noise-sensitive environment, extra measures may need to be taken. |
| 4. Drainage/water runoff | |

6.4 Adjustable feet for vibration damping (accessory)

When mounting on a solid floor, there are two alternative, adjustable feet for vibration damping

- Adjustable foot with steel spring damper
- Sylodyn foot with Sylodyn mat

6.4.1 Adjustable foot with steel spring damper (accessory) - EHPT-05



In spaces with plastic matting, the feet are placed directly on the floor without being anchored. If the unit is placed directly on a concrete floor, the feet can be anchored to the floor with bolts.

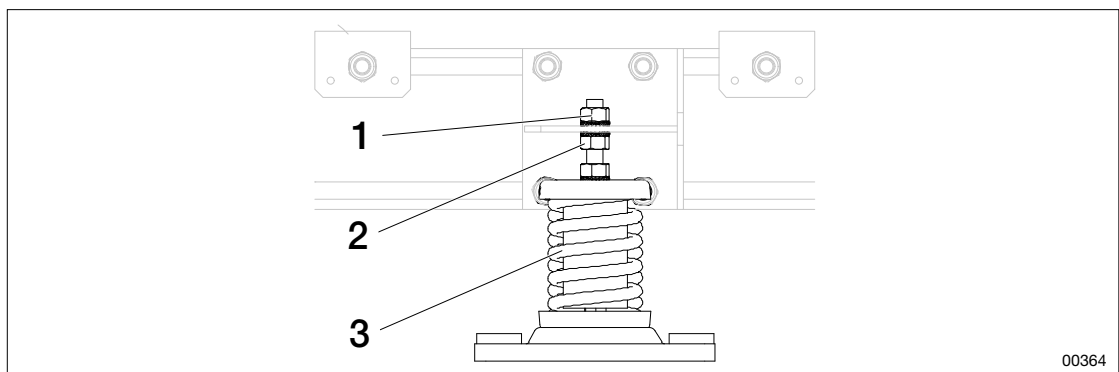

Figure: Steel spring damping

1. Upper adjusting nut
2. Lower adjusting nut

3. Steel spring damping

1. Make sure the bottom nut is in the lowest position against the damper.
2. Screw down the lower adjusting nut so that there is room to get the threaded rod through the hole in the frame.
3. Screw the upper nut above the plate.
4. Adjust the height of the foot by moving the upper and lower nuts.



Assembly instructions EcoHeater

6.4.2 Sylodyn foot with Sylodyn mat (accessory) - AMMT-01



The Sylodon mats are different colours depending on hardness (damp-
ing). See technical data for the unit.

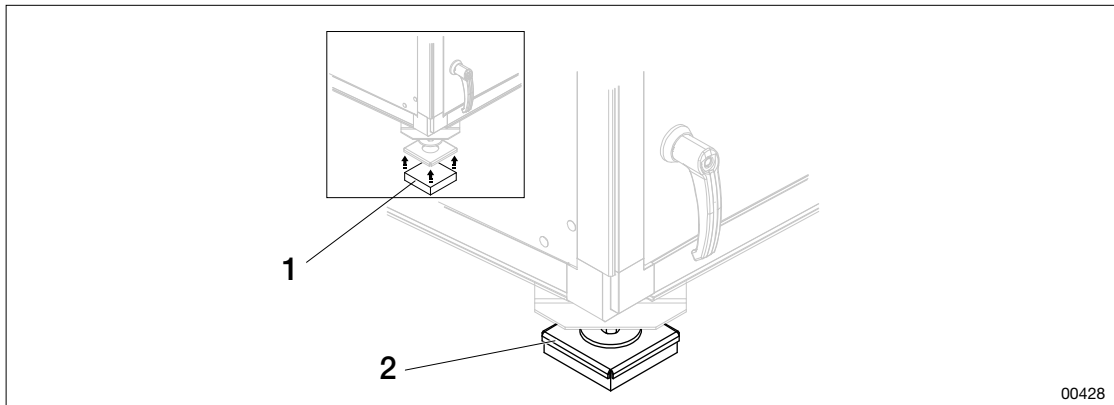

Figure: Vibration damping accessories

1. Sylodyn mat

2. Sylodyn foot with Sylodyn mat under the plate

1. Place the Sylodyn mat under the plate.
2. Assemble the foot in the corner of the unit.

7 ASSEMBLE

Read and follow each step carefully to avoid making mistakes and causing injury to people or damage to the environment or the unit. See "[1 SAFETY](#)", [page 5](#), "[5 LIFTING UNIT](#)", [page 14](#) and "[6 PREPARE FOR ASSEMBLY](#)", [page 18](#) before starting assembly.

WARNING!

Risk of life-threatening or serious personal injury.



Electrical voltage can cause electric shock, burns and death. The product must not be energised during assembly.

- Electrical connection and electrical work may only be carried out by a qualified electrician.
- For initial start-up of the unit, see Operation and Maintenance of the unit on IV Produkt's Order portal.

00176

WARNING!

Risk of life-threatening or serious crushing or compression injury.



The unit parts are often heavy and cannot be lifted by hand. See weights indicated on the layout drawing.

- Follow the lifting and assembly instructions in this manual.
- Use lifting equipment where available.
- Use appropriate protective equipment.

00179

7.1 Tools for assembly

Each unit is supplied with a bag of screws, nuts, corner fittings and other items to be used during assembly. The following tools are required for assembly:

- Screwdriver with 16-socket, 13-socket, 1/4-inch bit, Phillips bit
- Screwdriver
- Spirit level
- Torch
- Sealant gun
- Rubber mallet
- Scissors
- Multi-grip pliers
- Ring spanners 13, 16, 18, 19
- Wooden blocks to place between the support and the wall
- Pop rivet pliers
- Grease in spray bottle
- Pipe cutter

7.2 Assemble, step by step

1. Look at the installation drawing supplied with the unit or download it from IV Produkt's order portal (Technical data). See "[2.1 Documentation and support](#)", [page 10](#).
2. Prepare the appropriate tools.
3. Install and adjust the feet so that the unit is flat and level. See "[7.3 Adjusting the unit feet](#)", [page 24](#).
4. Install sealing strips. See "[7.5 Install sealing strip](#)", [page 25](#).
5. Push together and join the assembly parts. See "[7.6 Connect parts](#)", [page 26](#).
6. Connect the unit parts with quick connectors and connect other control equipment.
7. Connect the pipe system and install a water trap. See "[8 CONNECT PIPE SYSTEM AND WATER LOCK](#)", [page 28](#).
8. Assemble the cover. See "[7.8 Assemble cover detail at joint](#)", [page 27](#).
9. Make sure everything is assembled correctly. See "[11 AFTER ASSEMBLY](#)", [page 34](#) if problems arise "[2.1 Documentation and support](#)", [page 10](#).



Assembly instructions EcoHeater

7.3 Adjusting the unit feet

7.3.1 Adjustable feet on bottom beam

Unit feet on the bottom beam must be mounted on the beam before adjustment:

1. Screw the locking nut (1) onto the support feet (2) and make sure it is screwed in a little.

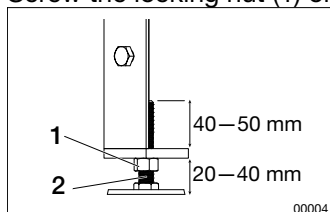

2. Use a spirit level to check that the unit is level. If not, adjust by screwing on the support feet.
3. Lock all feet with the locking nut.

7.3.2 Adjustable feet on other variants

On other variants (not bottom beam) the feet are mounted upon delivery. They are screwed in to their innermost position. Before installing the unit, they must be unscrewed approximately 25 mm to allow for adjustment when the unit is in place.

7.4 Assemble weather hood outdoors (optional)

The weather hood is only used for outdoor installation. Upon delivery, the weather hood is assembled in transport position, under the damper and exterior wall grille. Self-drilling screws for assembly are supplied with units with weather hoods.

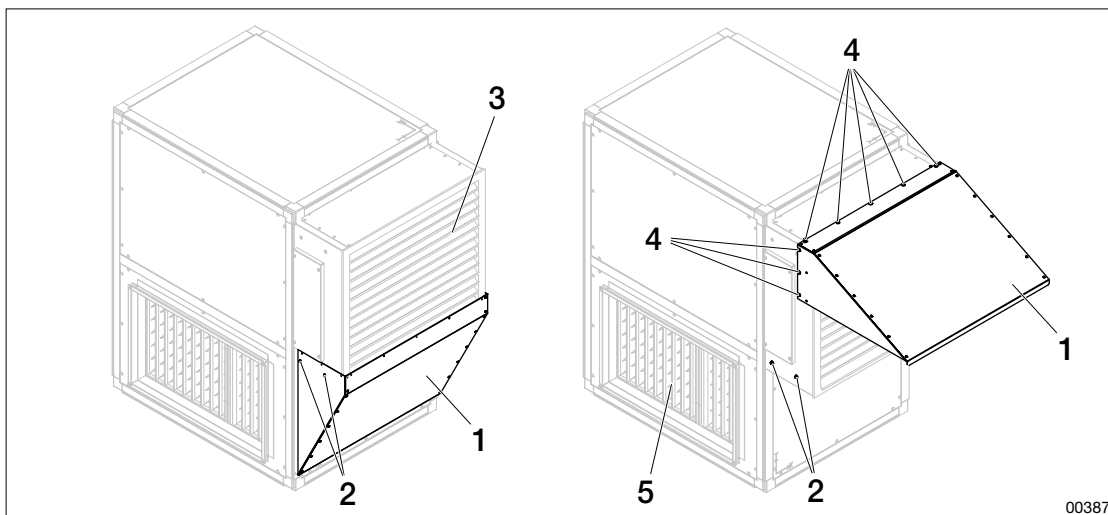

Figure: Weather hood in transport position (left) and assembled (right)

- | | |
|--------------------------------------|------------------------|
| 1. Weather hood | 4. Self-drilling screw |
| 2. Screw M6x16 (2 pcs) | 5. Duct connection |
| 3. Dampers and exterior wall grilles | |

1. Loosen the M6 screws on both sides.
2. Remove the hood.
3. Assemble the hood above the dampers and exterior wall grilles on both the roof and sides. Screw into the pre-punched holes using the supplied self-drilling screw.

7.5 Install sealing strip



- The sealing strip is mounted only on one of two opposing parts.
- For outdoor units, the sealing strip must also be installed on the outer edge, see "[7.5.1 Sealing strip for outdoor use](#)", page 25.

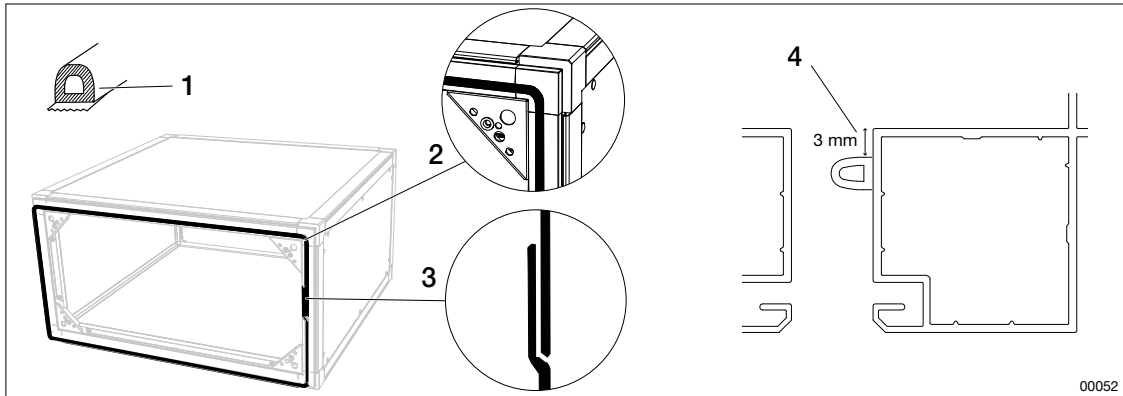

Figure: Sealing strips, placement.

- | | |
|--|---|
| <ol style="list-style-type: none"> 1. Sealing strip type D-profile 2. Sealing strip in corners | <ol style="list-style-type: none"> 3. Sealing strip joint 4. Profile in cross section |
|--|---|

1. Divide the strip into two strips.
2. Install the strip in the intermediate surfaces of the unit, approximately 3 mm from the inner edge. Peel off the protective layer over the adhesive as the strip is glued on. Bend the strip at the corners and join the vertical sides.

7.5.1 Sealing strip for outdoor use

On outdoor units, a strip must also be installed on the outer edges.

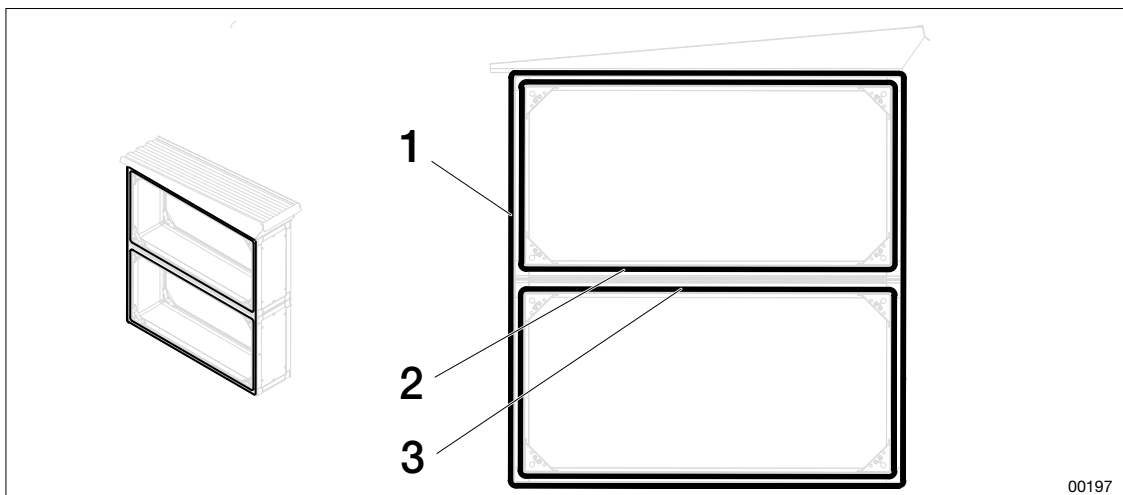

Figure: Placement of sealing strips for exterior construction

- | | |
|---|--|
| <ol style="list-style-type: none"> 1. Sealing strip on the outer edge around the entire two-story section 2. Sealing strip around the top | <ol style="list-style-type: none"> 3. Sealing strip around the bottom |
|---|--|



Assembly instructions EcoHeater

7.6 Connect parts



- In the lowest joint between the fan section and the compressor section, guide pins must be used as there is no access to insert screw connections at the bottom, furthest into the unit.

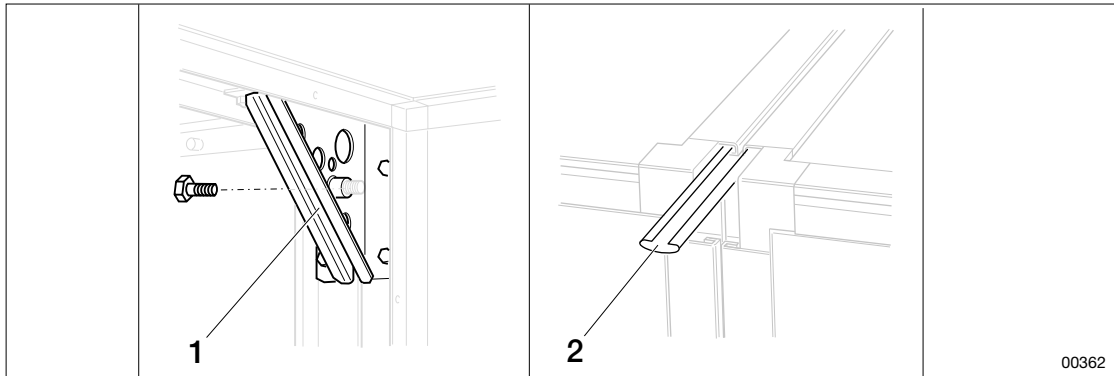

Figure: Screw connections and guide pins

1. Screw connection

2. Guide pins

7.6.1 Join with screw connections

1. Remove any cover plugs to access the screw connections.
2. Screw the unit parts together with bolts through the respective corner braces.

7.6.2 Join with guide pins



- The guide pin must always be inserted all the way from corner to corner of the unit parts, as well as on the opposite side.

Make sure that the unit parts are pushed together completely.

1. Pull the parts together with straps.
2. Slide the guide pin into the profile's groove, all the way to the other end of the unit.
3. Do the same on the opposite side of the unit.

7.7 Quick connectors

See order-specific documentation (Control diagram) at IV Produkt's order portal.

Quick connectors are connected between the fan section and the compressor section. Quick connectors that are to be connected together are marked with the same designation.

7.7.1 Quick connector, signal input

1. Press together the quick connectors according to markings.

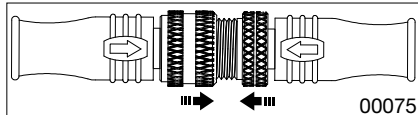

2. Screw together as tightly as possible by hand.

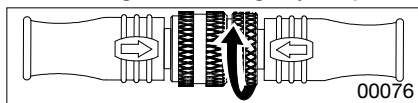

7.7.2 Quick connector, power supply

1. Press the quick connector together according to the marking.

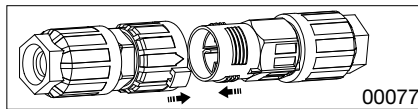

2. Turn the arrow on the white cuff towards the closed (padlock) marking.

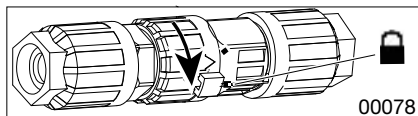

7.8 Assemble cover detail at joint

1. Once the unit parts have been joined, install the cover (1) over the joint.

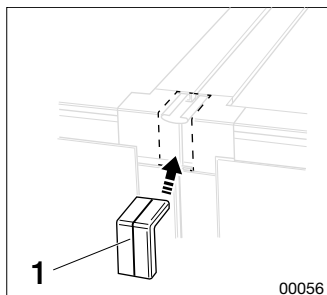

2. Make sure it is firmly attached.



Assembly instructions EcoHeater

8 CONNECT PIPE SYSTEM AND WATER LOCK

For proper function, the pipe system must be supplemented with the necessary pumps, balancing valves, etc.



- Always use a counterweight when connecting.

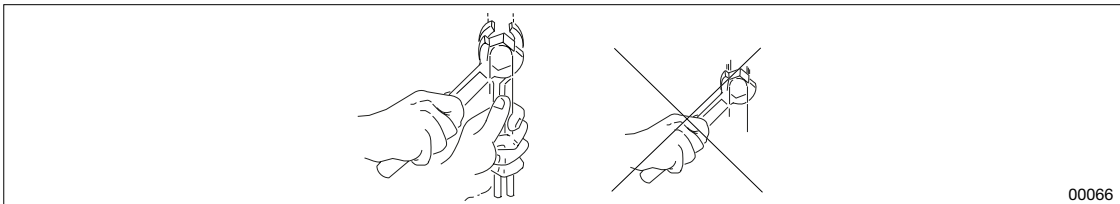

00066

Figure: Pipe connection counterweight

8.1 Schematic diagram, recommended connection

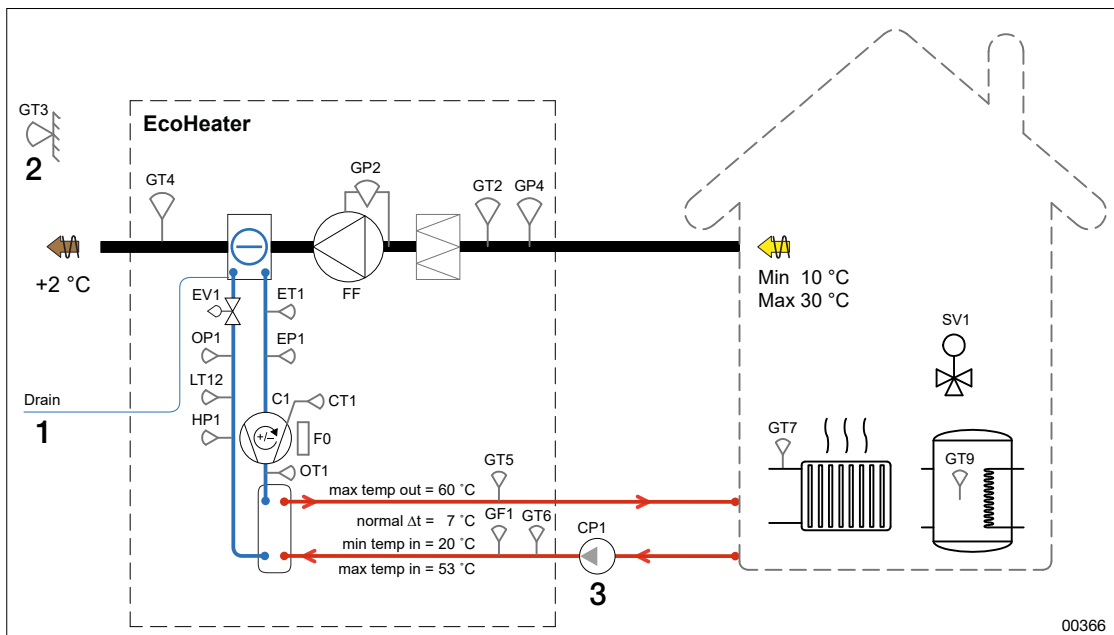

00366

Figure: Schematic diagram, recommended connection

1. Condensate drain (frost-protected)
2. Outdoor air temperature sensor (placed north-east)
3. Circulation pump, heat pump

8.2 Connection of liquid side

Dirt filters/cleaning filters, shut-off valves, safety valves and vent valves are not supplied by IV Produkt.

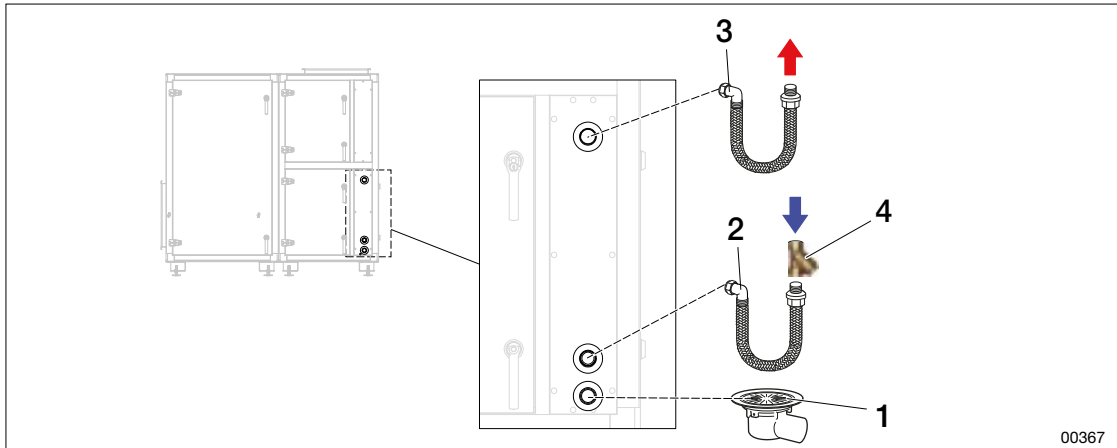

Figure: Connecting liquid

- | | |
|---------------------|--------------------------------|
| 1. Condensate drain | 3. Connection OUT |
| 2. Connection IN | 4. Dirt filter/cleaning filter |

1. Connect the supplied flexible hoses with the enclosed compression fittings to the exhaust air heat pump's IN and OUT connections. The hoses should be installed with a 180° bend and a minimum bend radius of 180 mm.
2. Install dirt filters/cleaning filters on connection IN.
3. If shut-off valves are installed on the connections, a safety valve should be installed after the shut-off valves towards the compressor side to avoid water being trapped. The connections can also be supplemented with vent valves.
4. Route the condensate drain (ABS plastic pipe, Ø32) to a floor drain or equivalent drain for draining condensate.
5. After completing the liquid side connection, bleed the system at its highest point.
6. Provide connecting pipes with venting at the highest point and draining at the lowest point.



Assembly instructions EcoHeater

8.3 Water trap



- Water traps are not used for outdoor installations.
- When installing indoors, a water trap is used to avoid any possible odour.
- If Exhaust air heat pump installed in a cold space, the pipes should be insulated.
- If the exhaust air heat pump is installed in an attic, a heating cable must be installed at the water drain.

- All drains should be connected to separate water traps, which can then be connected to a common drain.

For instructional videos see IV Produkt's order portal:

- Water trap, site-built assembly
- Water trap prefabricated MIET-CL-04 assembly.
- Fill the water trap with water before starting the unit.
- For every additional 100 Pa (over 1000 Pa), H_1 and H_2 are increased by 10 mm.

8.3.1 Connect water trap

MIET-CL-04 (accessory)

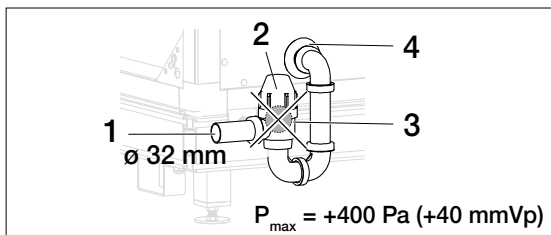

Site-built

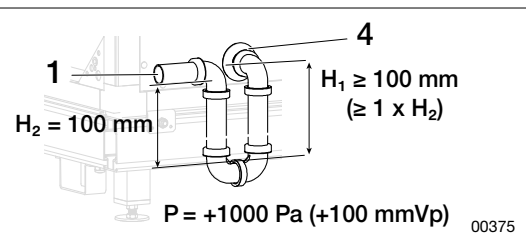

Figure: Water trap (accessory)

1. Outlet (connects to drain)
2. Cup (always mounted upwards)
3. Ball inside the tube (removed in case of overpressure)
4. Inlet, connected to the machine's drainage.

9 CONNECT POWER SUPPLY AND COMMUNICATION



WARNING!

Risk of life-threatening or serious personal injury.

Electrical voltage can cause electric shock, burns and death. The product must not be energised during assembly.

- Electrical connection and electrical work may only be carried out by a qualified electrician.
- For initial start-up of the unit, see Operation and Maintenance of the unit on IV Produkt's Order portal.

00176

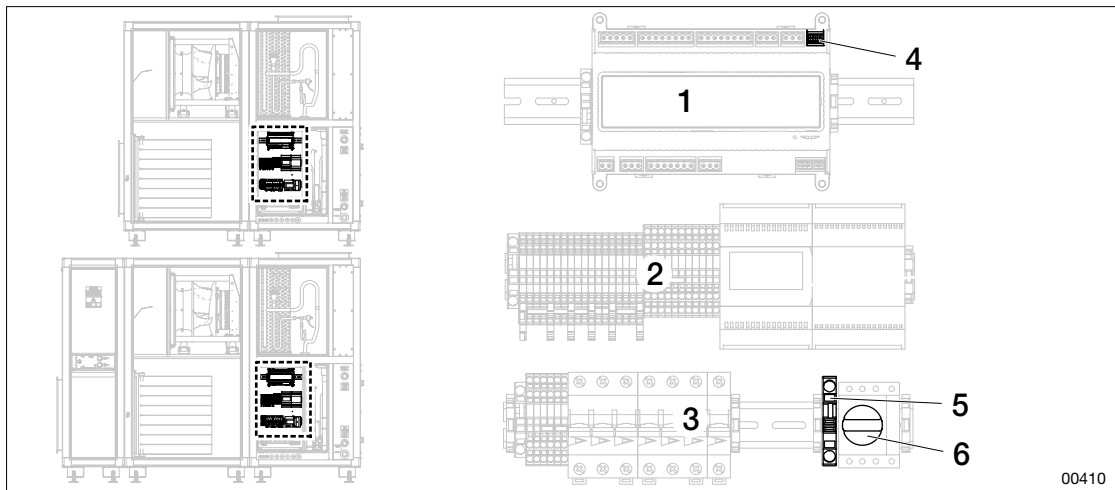

00410

Figure: Power supply and communication

1. Climatrix RC1
2. Terminals for connecting external control equipment/components, see control diagram.
3. Circuit breaker
4. T6 - Modbus communication (option for controlling heating requirement)
5. Earthing system
6. Main switch

9.1 Connection

For connection, see control diagram on IV Produkt's order portal.

1. Connect power supply to the main switch in the compressor section.
2. If applicable, establish communication with the substation (BMS) via COM or signal cable to terminal according to the control diagram. For communication (COM) options, see Control diagram.
3. Connect the signal from the outdoor air temperature sensor, via COM or signal cable on the terminal block, according to the control diagram.

9.2 Recommended fuse and power supply

See Technical data on IV Produkt's order portal.



Assembly instructions EcoHeater

IV Produkt's order portal

10 DUCT ACCESSORIES

WARNING!
Risk of injury and flammable atmosphere
The air flow in the exhaust duct must not be blocked so as to prevent the evacuation of refrigerant in event of leakage.

- Nothing (such as dampers) may be fitted in the exhaust air duct to cause the air flow to be stopped/blocked or obstructed.

00427

Duct accessories should be placed according to the installation drawing. Custom drawings can be downloaded at IV Produkt's order portal (Technical data). See "[2.1 Documentation and support](#)", page 10 and "[2.4 Symbols on drawings and in manual](#)", page 11. Exhaust air heat pump Can be ordered with smoke connection on the back, gable end or roof.

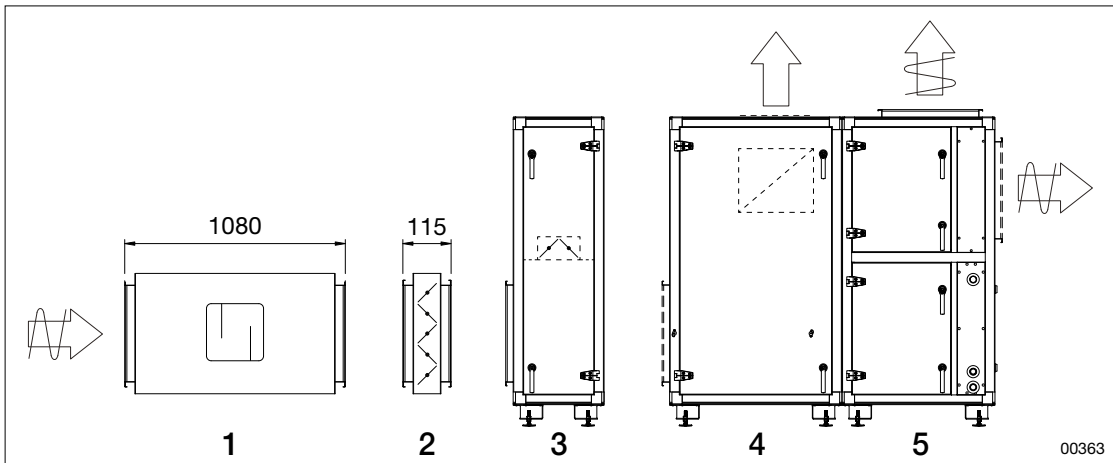

Figure: Example sketch, exhaust air heat pump with duct accessories

- | | |
|--|---------------------------|
| 1. Silencer, EMT-02 | 4. Fan part, EHP-F |
| 2. Shut-off damper, EMT-01 | 5. Compressor part, EHP-C |
| 3. Fire bypass section with internal damper EHP-B (option) | |

10.1 Connection to rectangular duct

Exhaust air heat pump Supplied with rectangular connection socket. Connection sockets on rectangular duct connections must be supplemented with a sealing strip and connected with guide strips.

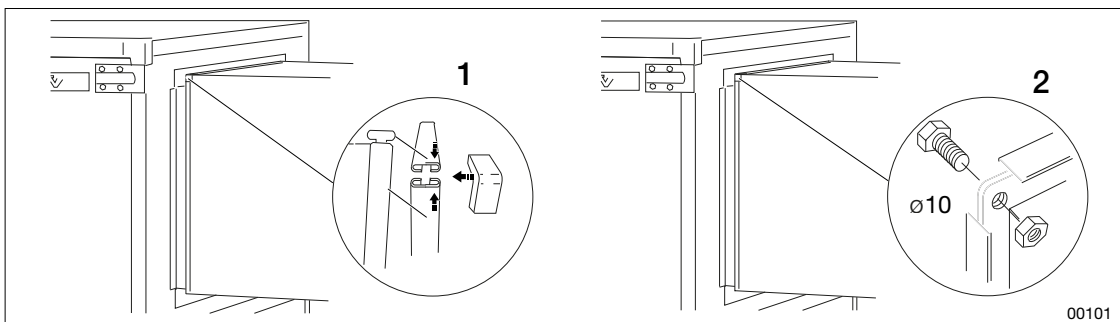

Figure: Rectangular connecting socket

- | | |
|---|--|
| 1. Option 1: The channels are connected with gaskets, guide pins and outer corners. | 2. Option 2: The channels are connected with screws at the corners of the frame. |
|---|--|

10.2 Connect the fabric sleeve (accessory)

If a fabric sleeve is connected for vibration damping, duct insulation must be installed over the entire connection.

10.3 Install sound attenuator (EMT-02)

Sound attenuators are assembled with rectangular connection sockets for guide systems.

10.4 Install shut-off damper (EMT-01)

Dampers, for horizontal or vertical air flow, are assembled with a rectangular connection piece for guide systems.

10.5 Fire bypass section with internal damper (EHP-B)

Module part with internal damper opens for by-pass over filter in case of alarm, assembled with rectangular connection piece for guide system.

10.6 Install Weather hood smoke back (EHPT-08)

The hood is supplied together with a fire bypass part for outdoor installation with a smoke connection on the back. See "[7.4 Assemble weather hood outdoors \(optional\)](#)", page 24.



Assembly instructions EcoHeater

11 AFTER ASSEMBLY

11.1 Post-inspection and maintenance

 **CAUTION!**
Risk of damage to the product.
Swarf from drilling left behind after assembly can lead to corrosion and rust on the surface layer of the unit.

- Make sure that the surfaces of the unit are clean of swarf.

00195

 **CAUTION!**
Risk of damage to the product.
Corrosive substances and strong cleaning agents can damage the surface layer.

- Never use strong cleaning agents or corrosive substances when cleaning the unit.

00183

| Area | Control | Comment |
|-------------------------------|---|--|
| Covers | Make sure all doors are in place. | All sides should have gaps. |
| Covers | Make sure that inspection hatches do not jam when opened. | Adjust the door hinges. If it is not enough, adjust with the support feet. After adjusting the support feet, make sure that the unit does not lean backwards towards the back. |
| Internal surfaces of the unit | Make sure that the unit is clean and free of dirt and debris. | Vacuum or brush as needed. Use a damp cloth. |
| Internal surfaces of the unit | Make sure that the unit does not have any remaining dust from drilling. | Vacuum or brush after assembly. |
| Unit | Make sure that the unit is level. | Measure with a spirit level. Adjust if necessary. See " 7.3 Adjusting the unit feet ", page 24. |
| Drainage | Make sure the water trap is connected. | See " 8.3 Water trap ", page 30. |
| Placement | Make sure that the unit is not firmly connected to the building structure via cable ladders, pipe systems or similar so that transmission of vibrations is avoided. | |
| Duct system | Make sure that ducts are connected with vibration-damping fabric sleeves. Make sure that nothing is blocking the exhaust duct. | Dampers or other items must not block the exhaust air. |

Assembly instructions EcoHeater



Feel free to contact us



IV Produkt AB, Sjöuddevägen 7, S-350 43 VÄXJÖ
+46 470 – 75 88 00
www.ivprodukt.se, www.ivprodukt.com



Support:

Control: +46 470 – 75 89 00, styr@ivprodukt.se
Service: +46 470 – 75 89 99, service@ivprodukt.se
Spare parts: +46 470 – 75 86 00, reservdelar@ivprodukt.se
Documentation: +46 470 – 75 88 00, du@ivprodukt.se



IV Produkt's order portal
