



Climatix™

Climatix Controllers

POL635.XX/XXX

POL636.XX/XXX

POL638.XX/XXX

POL638.70/XXX

For controlling, switching and monitoring functions

The controllers are products of the Climatix range.

Also refer to Data Sheet 3900 and Mounting Instructions M3910

The POL63X controllers are designed for use in connection with compact air heating units or in ventilation, air conditioning and refrigeration plants.

Controller types



POL635.xx/xxx

Basic version SD card, modem, battery holder



POL636.xx/xxx

Basic version and LON interface



POL638.70/xxx

Basic version with HMI and TCP / IP interface



POL638.xx/xxx

Basic version and TCP / IP interface

The controllers offer the following features:

- Freely programmable
- Object-oriented programming by graphic editor SAPRO
- Expandability via peripheral bus for local or remote I/O extension modules
- Power supply AC 24 V or DC 24 V
- 8 universal I/Os (configurable inputs / outputs, for analog or digital signals)
- DC 24 V onboard power supply for active sensors
- 5 digital inputs (potential-free contacts)
- 2 analog outputs (DC 0...10 V outputs)
- 6 relay outputs (NO contacts)
- RS-485 in Modbus RTU model for third-party bus
- Full modem RS-232 port for remote service
- Process bus for connecting room units and remote HMI (DPSU)
- Up to 3 additional communication modules for BACS integration
- Local service connector for user interface (RJ45) and PC tools (USB)
- SD card for application and operating system upgrade
- LON field bus (POL636.00 only)
- Ethernet port for remote or local servicing using standard browsers (POL638.00 only)
- Operating temperature -20...60 °C (without LCD -40...70 °C)

Communication concept

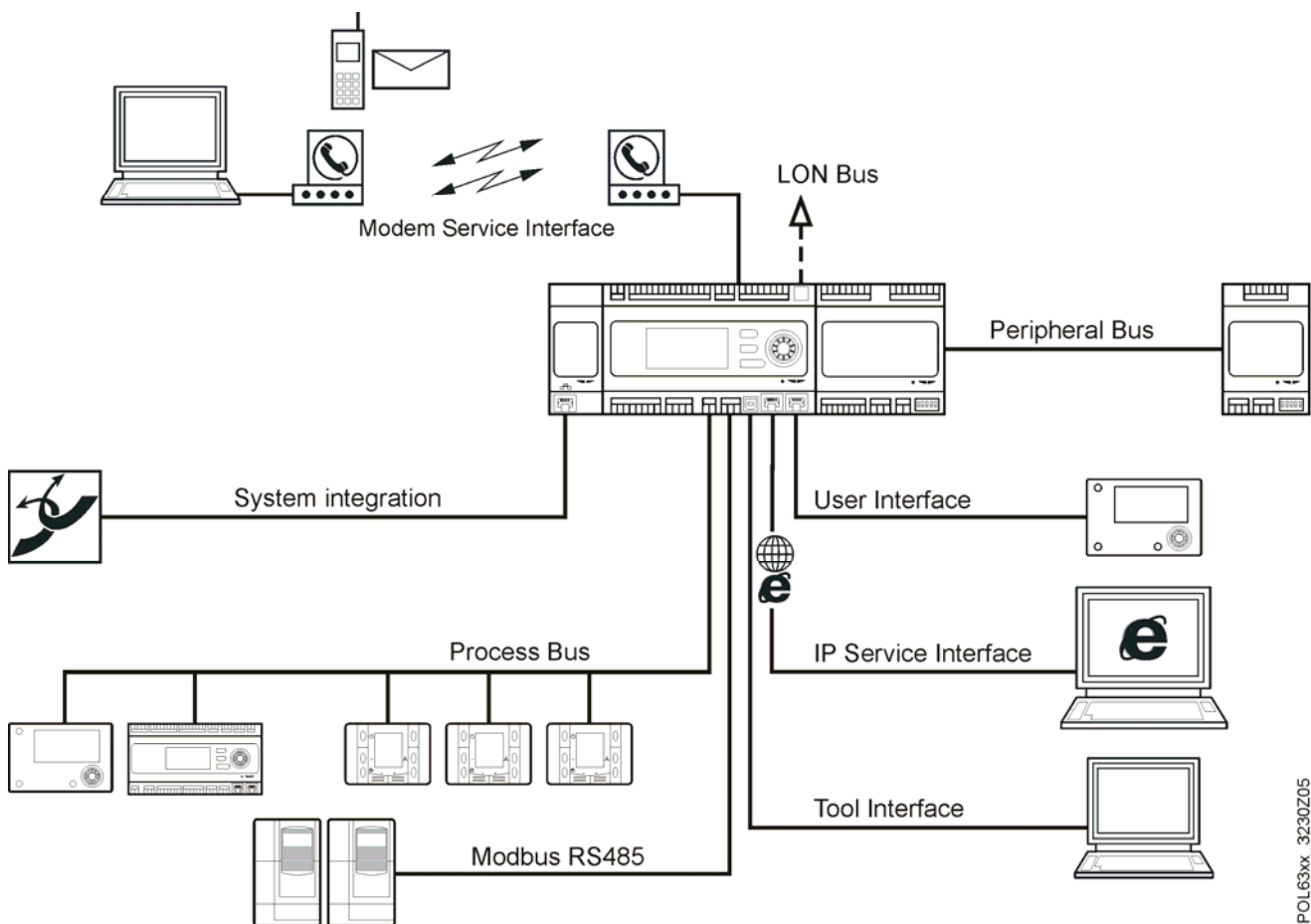

Connection terminals and plugs

Note



The LON interface is installed on POL636.XX/XXX only.
 The Ethernet interface is installed on POL638.XX/XXX only.

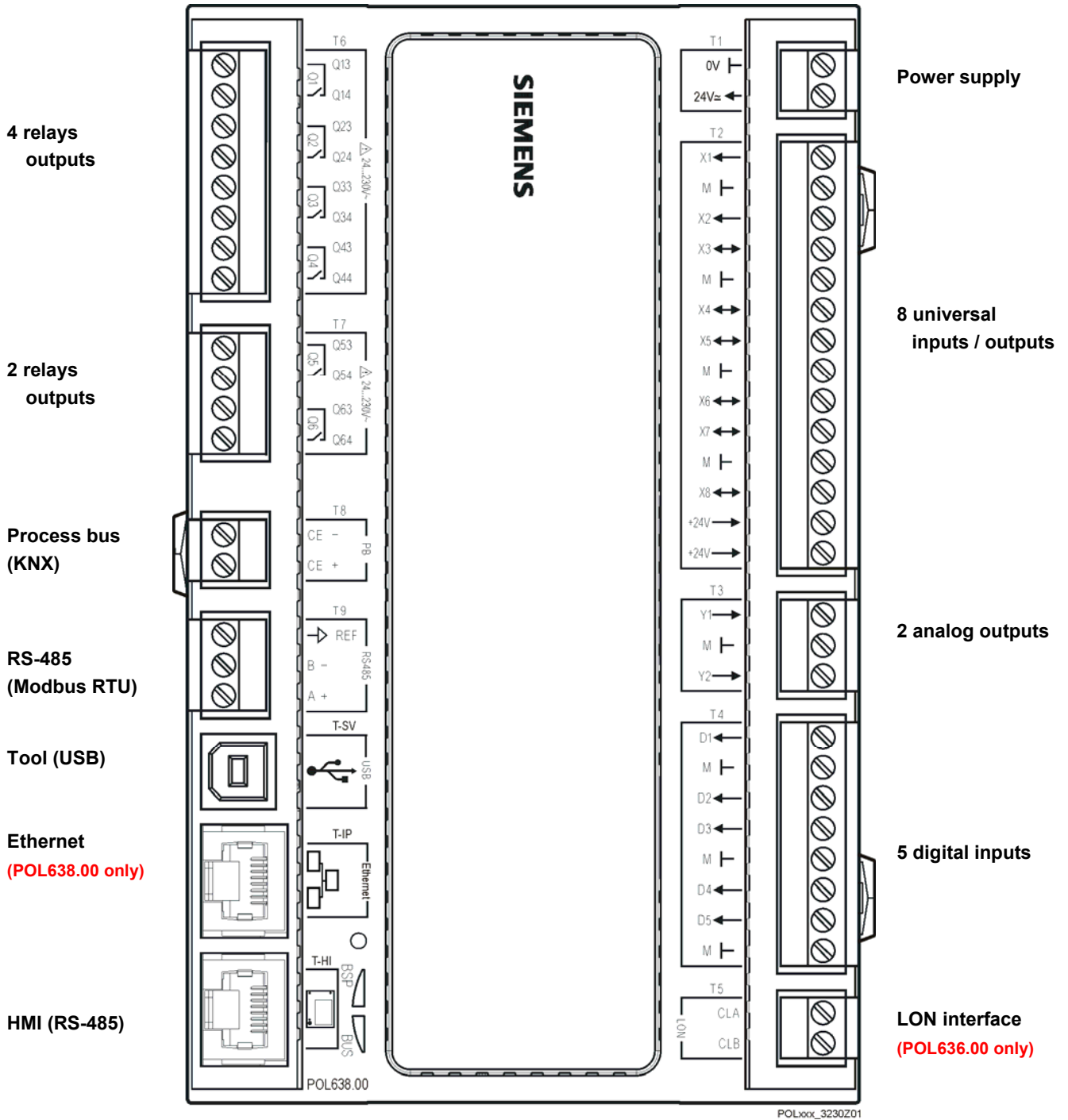

Power supply

0 V, AC/DC 24 V (T1)	Operating voltage	AC 24 V $\pm 20\%$; DC 24 V $\pm 10\%$
	Frequency	45...65 Hz
	Max. AC current without extension modules	1.8 A @ 24 VAC
	Max. DC current without extension modules	1.0 A @ 24 VDC
	Max. current for extension modules	2,2 A @ 24 VAC / 3.0 A @ 24 VDC
	Max. external supply line fusing	10 A slow wire fuse or circuit breaker

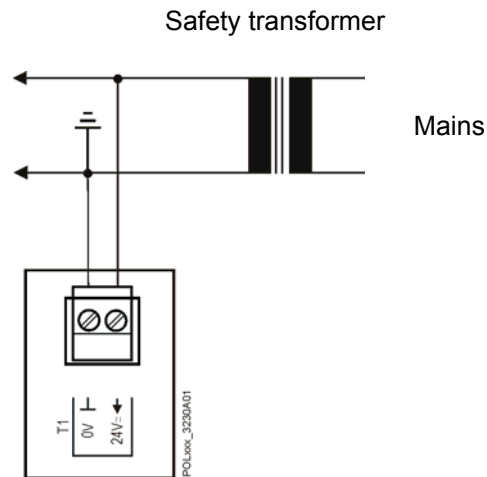

Connecting power supply

Relay outputs

Q1...Q6 (T6, T7)	Relay: Type, contact	Monostable, NO contact
	Contact rating	
	Switching voltage	AC 24...230 V (-20%, +10%)
	Nominal current (res. / ind.)	Max. AC 4 A / 3 A (cos ϕ 0.6)
	Switching current at AC 19 V	Min. AC 30 mA
	Max. external supply line fusing	6.3 A slow wire fuse or circuit breaker



Warning

Do not mix (SELV / PELV) and line voltage on the same terminal

Use external protection for inductive loads

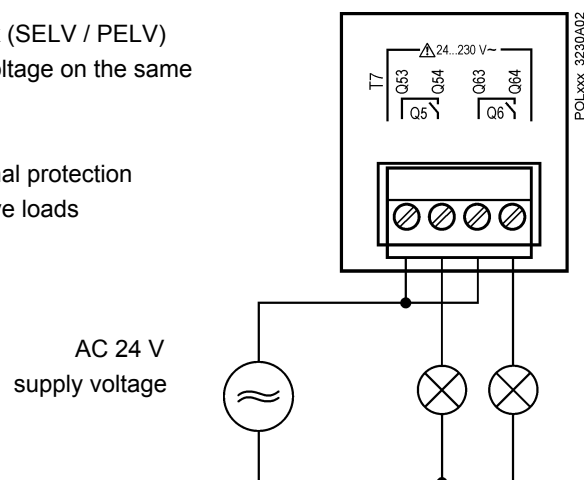

Connecting control lamps to relay output

Universal I/Os

X1,X2 only input
X3...X8 universal (T2)

Configurable
Reference potential
Contact voltage
Overvoltage protection

By software
Terminals \perp
Max. DC 24 V (SELV)
Up to 40 V

Analog inputs (X1...X8)

LG-Ni1000			
Sensor current	1.4 mA		
Resolution	0.1 K		
Accuracy within the range of -50...150 °C	0.5 K		
Pt1000			
Sensor current	1.8 mA		
Resolution	0.1 K		
Accuracy within the range of -40...120 °C	0.5 K		
NTC 10k			
Sensor current	140 μ A		
Temperature range	Accuracy	Resolution	
-50...-26 °C	1 K	0.2 K	
-25...74 °C	0.5 K	0.1 K	
75...99 °C	1 K	0.3 K	
100...124 °C	3 K	1.0 K	
125...150 °C	6 K	2.5 K	
NTC 100k			
Sensor current	140 μ A		
Temperature range	Accuracy	Resolution	
-25...-11 °C	3 K	0.2 K	
-10...9 °C	1 K	0.1 K	
10...99 °C	0.5 K	0.1 K	
100...150 °C	1 K	0.2 K	
0...2,500 Ω			
Sensor current	1.8 mA		
Resolution	1 Ω		
Accuracy	4 Ω		

Ratiometric sensor

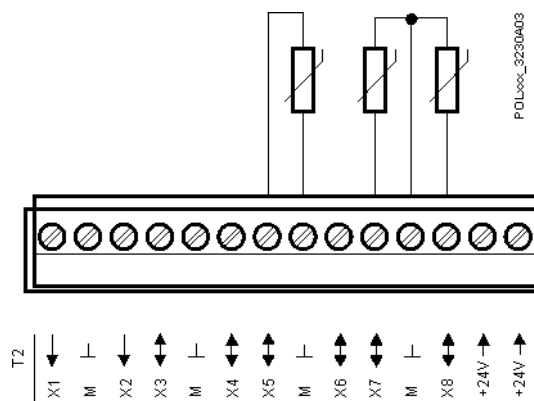

Connecting a ratiometric sensor to universal I/O

DC 0...10 V input	
Resolution	1 mV
Accuracy at 0 V	10 mV
Accuracy at 5 V	25 mV
Accuracy at 10 V	50 mV
Input resistance	100 k Ω

DC 0/4...20 mA input	
Resolution	1 μ A
Accuracy at 4 mA	40 μ A
Accuracy at 12 mA	70 μ A
Accuracy at 20 mA	120 μ A

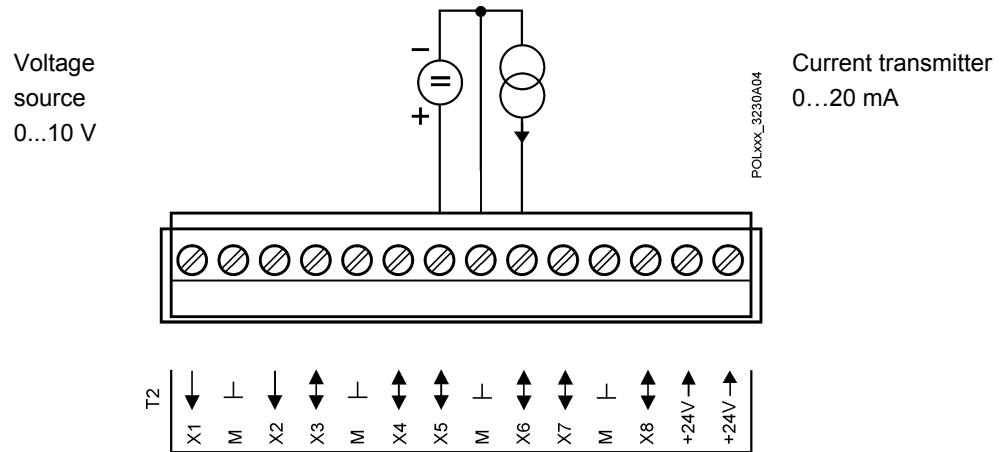

Voltage input DC 0...10 V and
Current input 0/4...20 mA

Digital inputs (X1...X8)

0/1 digital signal (binary)	For potential-free contacts
Sampling voltage / current	DC 24 V / 8 mA
Contact resistance	Max. 200 Ω (closed) Min. 50 k Ω (open)
Delay	10 ms
Pulse frequency	Regulated by cycle time of the Controllertask $f_{max} = 20$ HZ for $T_{cycl. max} \leq 25$ ms $f_{max} = 1 / (2 + T_{cycl. max})$ for $T_{cycl. max} > 25$ ms

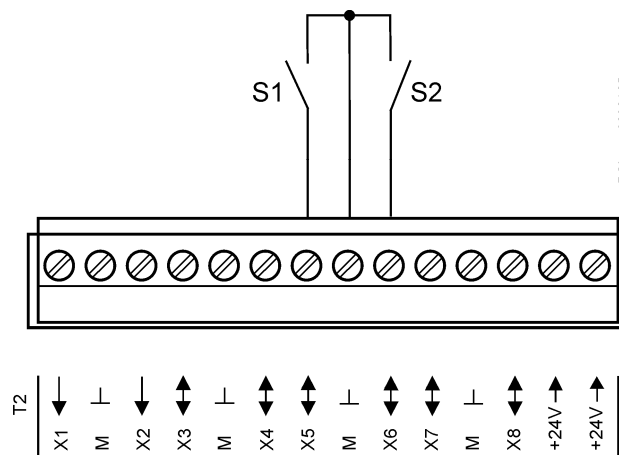

Connecting floating contacts to universal I/O

Analog outputs
(X3...X8)

DC 0...10 V output	
Resolution	11 mV
Accuracy at 0 V	66 mV
Accuracy at 5 V	95 mV
Accuracy at 10 V	124 mV
Output current	1 mA (short-circuit-proof)

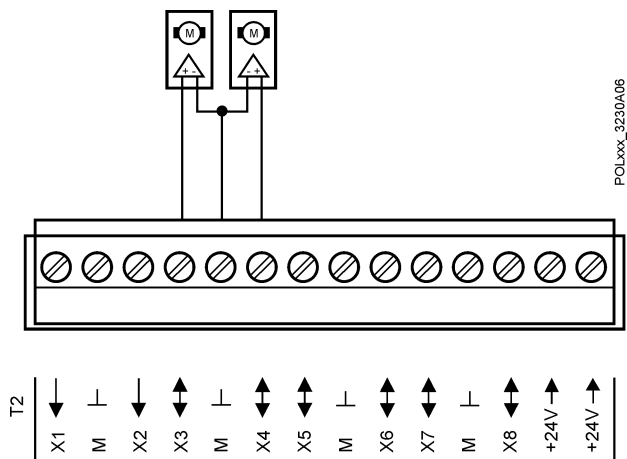

Connecting voltage output and current output to universal I/O

Digital outputs
(X5...X8)

DC output for off board loads	
Switching voltage	DC 24 V
Switching capacity	Max. 25 mA

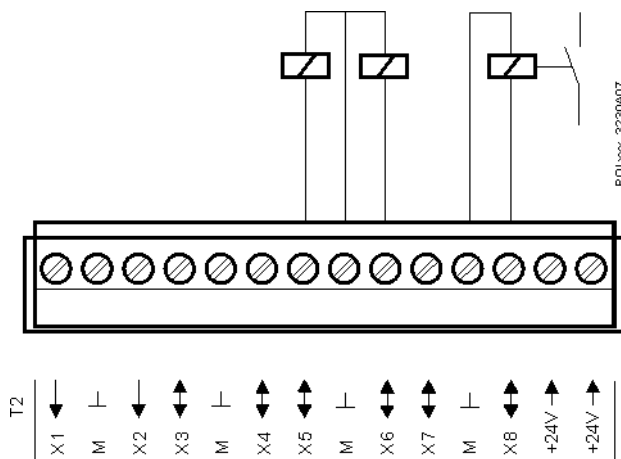

Connecting external relay to universal I/O

**Powering sensors;
active / ratiometric**
2 x 2 outputs +24 V

Voltage / current DC 24 V +10%, -25% / 2 x 40 mA
Reference potential Terminals \perp
Connection Short-circuit-proof

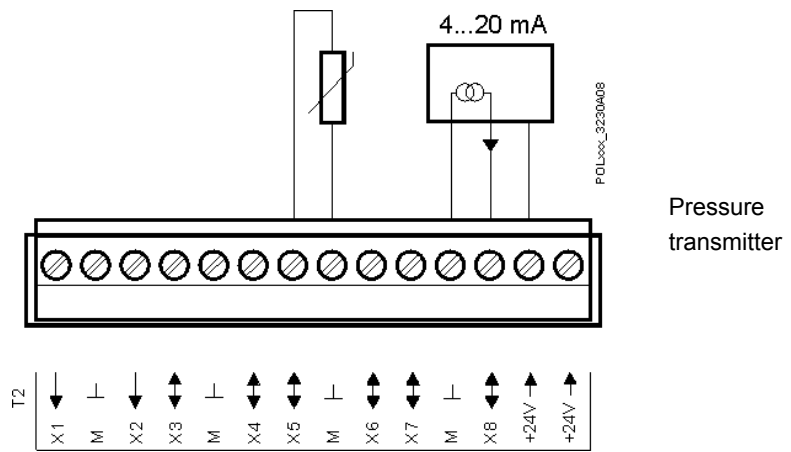

Connecting a sensor with AC 24 V supply voltage

Digital inputs
D1...D5 (T4)

0/1 digital signal (binary)
Sampling voltage / current DC 24 V / 8 mA
Contact resistance Max. 200 Ω (closed)
Min. 50 k Ω (open)
Delay 10 ms
Pulse frequency Max. 30 Hz

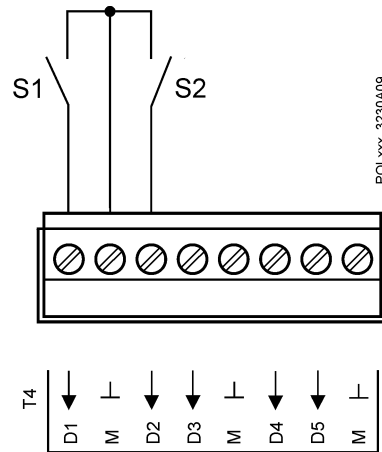

Connecting floating contact to digital input

Analog outputs

Y1, Y2 (T3)

DC 0...10 V output

Resolution

11 mV

Accuracy at 0 V

66 mV

Accuracy at 5 V

95 mV

Accuracy at 10 V

124 mV

Output current

2 mA (short-circuit-proof)

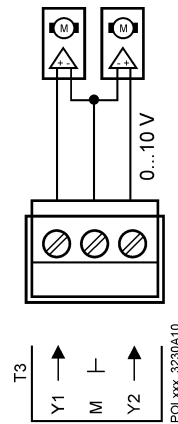

Connecting voltage-outputs 0...10 V

Interfaces

Process bus

CE+, CE- (T8)

Process bus

Bus connection 2-wire twisted pair

Bus connection / electronics

Bus load

Bus cable

Bus cable length between 2 KNX nodes

Total length of bus KNX cable

Bus power supply via

Based on KNX TP1 (refer to KNX Manual)

CE+, CE-, not interchangeable

Galvanically isolated

Max. 5 mA

Must be shielded; refer to KNX Manual

“System Specifications”

Max. length is 700 m

Max. length of KNX cable is 1000 m

Internal DPSU with 50 mA nominal current

External standard KNX power pack

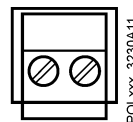
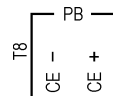

Connecting the process bus

MODBUS
(RS-485 RTU)
A+, B-, REF

RS-485 (EIA 485)	Modbus RTU mode
	2-wire twisted pair, shielded
Bus connection / electronics	Not galvanic isolated
Bus connection 2-wire twisted pair	A+, B-, REF
Bus termination (switched via software)	680 Ω / 120 Ω +1 nF / 680 Ω

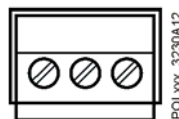
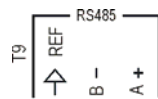

Connecting a MODBUS

Local service tool interface
T-SV

USB device interface	Socket type B
Cable connection	USB receptacle, series B
Standard cable	Length of cable <3 m

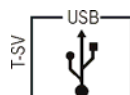

Connecting a USB interface

Local HMI interface
T-Hi

HMI (RS-485)	RJ45 jack, 8 pins
Cable connection	For tools use USB-Cable POL0C2
Cable (< 3 m)	HMI cable is with POL895.51 enclosed
HMI-Communication	RS485
HMI-Speisung	24 V max. 100 mA

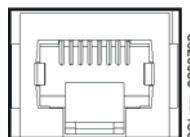

LEDs for diagnostics 3 colors (green, yellow and red)

LEDs

BSP Run/Stop LED

Mode	LED status
Update mode (download active or a new BSP, application)	Every second alternating between red and green
Application not loaded	Yellow blinking: 50 ms on and 1000 ms off
Application loaded but not running	Yellow on
Application running	Green on
BSP error (software error)	Red blinking at 2 Hz
Hardware error	Red on

Bus LED

This LED only indicates the status of the integrated modem communication. It does not indicate the status of the internal communication (to I/O or COM extension modules). This status is visible on the respective extension modules.

Mode	LED status
No modem connected, or LED disabled	Off
Modem connected and initialized no communication active	Yellow on
Modem connected and communication active	Green on
Modem connected but errors active (like provider missing, no initialization possible)	Red on

Modem service interface

Connection via plug at top right of the controller

Tool and modem (full modem interface)

Cable connection	RJ45 jack, 8 pins, at top right length of cable <3 m
Supported modem types	Siemens TC65 GSM modem terminal Devolo Microlink 56k I



SD card

Connection via plug at top right of the controller

SD card (SDHC)	Slot 128 MB...2GB
Data-system	FAT16, FAT32



Warning

Switching on and off during read-and-write access can lead to loss of data.

LON interface

CLA, CLB-

Plug-in terminals	2 wires, interchangeable 2-wires, twisted pair, shielded
Galvanically isolated	

Note



The LON interface is installed on POL636.00/XXX only.

Ethernet

IP service interface
TCP-IP

Communication
Cable connection

10/100 Mbit (IEEE 802.3U)
RJ45 jack, 8 pins

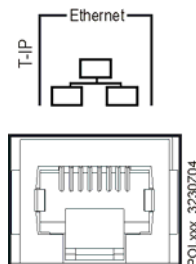

Connecting TCP/IP

Ethernet TCP/IP example

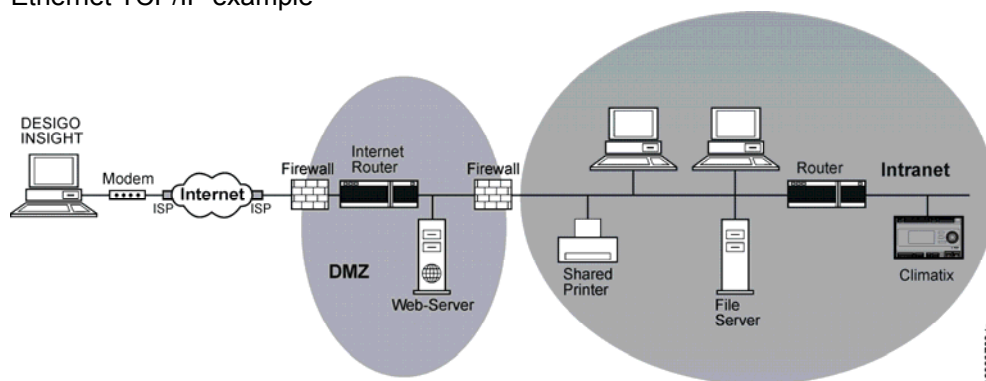

Note



The Ethernet interface is installed on POL638.00/XXX only.

Peripheral bus

COM – extension communication modules

Connection via plug on the bottom left side of the controller.
Based on SPI interface for the communication module connection.

Low-voltage power supply for com module	
Number of COM module	Max. 3 (self-acting module detection)
Voltage / current	DC 5 V \pm 10% / max. 1 A
	Short-circuit-proof
Board-to-board connector (not included)	ZEC1,0/10-LPV-3,5 GY35AUC2C11



I/O – extension I/O modules

Connection via plug at bottom right of the controller.
Based on RS-485 interface for the I/O module connection.

Power supply in the controller	$U_{\text{eff}} = \text{AC } 24 \text{ V } \pm 20\%$, $f_{\text{main}} = 45 \dots 65 \text{ Hz}$ or $U = \text{DC } 24 \text{ V } \pm 10\%$, no internal fuse
Bus termination selectable	(680 Ω / 120 Ω +1 nF / 680 Ω)
Connector (not included)	Board-to-board: ZEC 1,0/4-LPV-3,5 C1 Board-to-wire: ZEC 1,0/4-ST-3,5 C1R1
Solid wire	0.2...1.0 mm ²
Stranded wire (twisted or with ferrule)	0.2...1.0 mm ²
Cable lengths	Max. 30 m

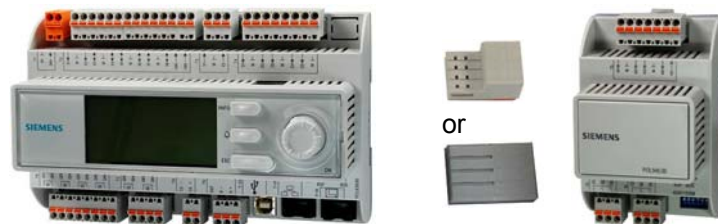

Technical data

Real-time clock	Buffering with internal gold cap	Min. 3 days
	Buffering with additional battery	Min. 200 days
Inbuilt HMI	LCD with white backlight	144 x 64 dots
	Navigation	Roll-and-push knob 3 function buttons
Environmental conditions	Operation	IEC 721-3-3
	Temperature	-40...70 °C
	Restriction HMI	-20...60 °C
	Restriction process bus	-25...70 °C
	Restriction with 1 com module	-40...65 °C
	Restriction with 2 com modules	-40...60 °C
	Humidity	<90% r.h. (non-condensing)
	Atmospheric pressure	Min. 700 hPa, corresponding to max. 3,000 m above sea level
	Transport	IEC 721-3-2
	Temperature	-40...70 °C
	Humidity	<95% r.h. (non-condensing)
Atmospheric pressure	Min. 260 hPa, corresponding to max. 10,000 m above sea level	
Protection	Degree of protection	IP20 to EN 60529 with RJ45 jack at top right IP10 to EN 60529 without RJ45 jack at top right
	Safety class	Suitable for use in safety class II plant
Standards	Product safety	
	Automatic electrical controls	EN 60730-1
	Electromagnetic compatibility	Suitable for residential and industrial EMC environment
	Immunity	EN 60730-1 +A16
	Emissions	EN 60730-1 +A16
	CE conformity	
	EMC directive	2004/108/EEC
	Low-voltage directive	2006/95/EEC
	C-tick conformity	
	In accordance with AU EMC framework	Radio Communications Act 1992 AS/NZS CISPR11
UL approvals	UL916, UL873	
Signal equipment certified for Canada	CSA C22.2M205	
RoHs compliance	2002/95/EC (Europe) ACPEIP (China)	
General data	Dimensions of controller	180 x 110 x 75 mm
	Weight excl. packaging	
	Controller without HMI	487 g
	Controller with HMI	422 g
	Base	Plastic, pigeon-blue RAL 5014
	Housing	Plastic, light-grey RAL 7035

Order data

Basic controller ACX35 EVO	POL635.00/XXX
Basic controller ACX36 EVO with LON interface	POL636.00/XXX
Basic controller ACX38 EVO with TCP/IP interface	POL638.00/XXX
Basic controller ACX38 EVO with TCP/IP interface and HMI	POL638.70/XXX
Connector set screw type (not included)	POL063.85/STD

Plug set



Example FKCT

The necessary plug set (connector set) is not included with the controller

1 positions (Phoenix MVSTBW, FKCCW or FKCT 2,5/2-ST)	Orange
3 positions (Phoenix MVSTBW, FKCCW or FKCT 2,5/2-ST)	Grey
2 positions (Phoenix MVSTBW, FKCCW or FKCT 2,5/3-ST)	Grey
1 positions (Phoenix MVSTBW, FKCCW or FKCT 2,5/4-ST)	Grey
2 positions (Phoenix MVSTBW, FKCCW or FKCT 2,5/6-ST)	Grey
2 positions (Phoenix MVSTBW, FKCCW or FKCT 2,5/8-ST)	Grey

Connection terminals

For I/O signals	Plug-in terminals: Screw / clamp Color: Gray Grid: 5 mm
For communication	Plug-in terminals: Screw / clamp color: Gray Grid: 5 mm
For power supply	Plug-in-terminals: Screw / clamp Color: Orange Grid: 5 mm
Solid wire	0.5...2.5 mm ²
Stranded wire (twisted or with ferrule)	0.5...1.5 mm ²
Cable lengths	In compliance with the load, local regulations and installation documents

Engineering notes



Warning

To ensure protection against accidental contact with relay connections at voltages above 42 V_{eff}, the device must be installed in an enclosure (preferably a control panel). It must be impossible to open the enclosure without the aid of a key or tool. AC 230 V cables must be double-insulated against safety extra low-voltage (SELV) cables.

Disposal notes



The controller contains electrical and electronic components and must not be disposed of together with household waste.

Local and currently valid legislation must be observed!

Dimensions

Dimensions in mm

POL63X.00/XXX

