

Climatix™ C600

HVAC&R controller

POL648.x0, POL688.x0, POL69x.x0



Climatix C600 controllers for heating, ventilation, air conditioning and refrigeration equipment.

- Freely programmable modular controllers
- 21, 27 and 29 physical inputs / outputs per controller
- Integrated stepper motor outputs with failsafe behavior (UPS)
- Integrated local or remote HMI
- Standard USB service connection for tool access
- Ethernet port for local/remote servicing and Climatix IC connectivity
- SD card interface with for applications, firmware download, and archiving
- Physical input/output extension using extension modules
- Third-party integration using the built-in RS-485 interfaces for Modbus RTU
- Networking over the process bus
- Communication module connectivity for additional BACnet IP, BACnet MS/TP, M-bus, LON and OPC
- Operating temperature range: -40...70 degree Celsius

Field of application

Climatix products are designed for use in heating, ventilation, air conditioning and refrigeration machines and provide a broad range of control and monitoring functions.

The number and type of I/Os on the controller and extension modules are optimized for these application types.

Modular design

The product range is of modular design and primarily comprises controllers and various add-on I/O and communication modules. Different HMIs can be connected to the controllers, either directly (local HMI) or via the network (remote HMI).

Freely programmable

The Climatix controllers are freely programmable using a powerful graphical software tool (SAPRO). A number of defined inputs/outputs (analog or digital) plus freely programmable I/O channels make it possible to create a host of applications with or without additional modules.

Communications

On-board communication interfaces complete the scalable and intelligent control system. Additional communication modules can be added to the system in accordance with integration requirements.

Topologies

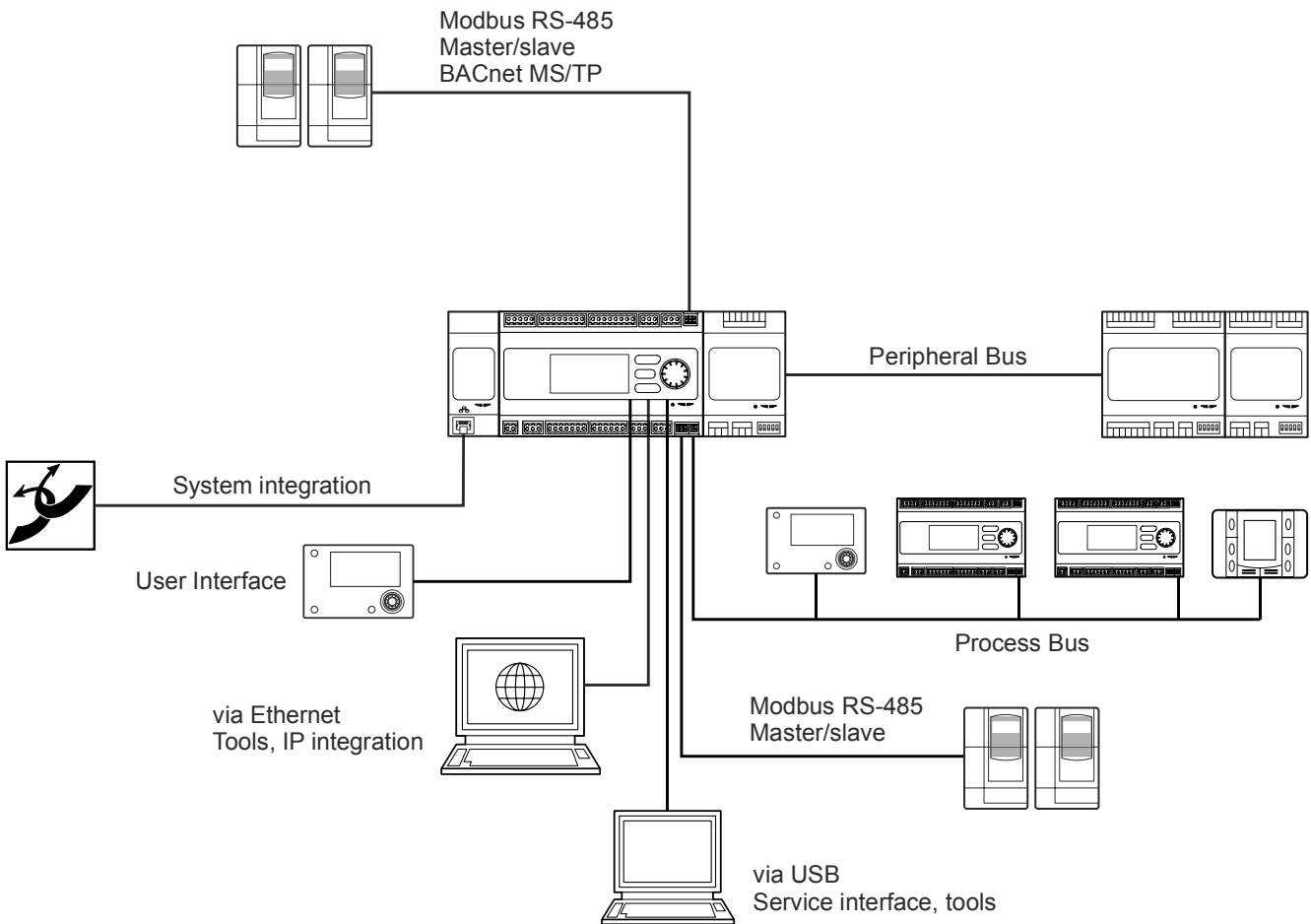

The Climatrix C600 product range consists of three controller types with 21, 27, and 29 physical inputs and outputs.

The design and configuration of the inputs/outputs and interfaces are conceptually equal for all controller types.

The controllers are available with and without integrated HMI.

The following figures display the three basic types, each with integrated HMI.

POL648 - 21 inputs and outputs

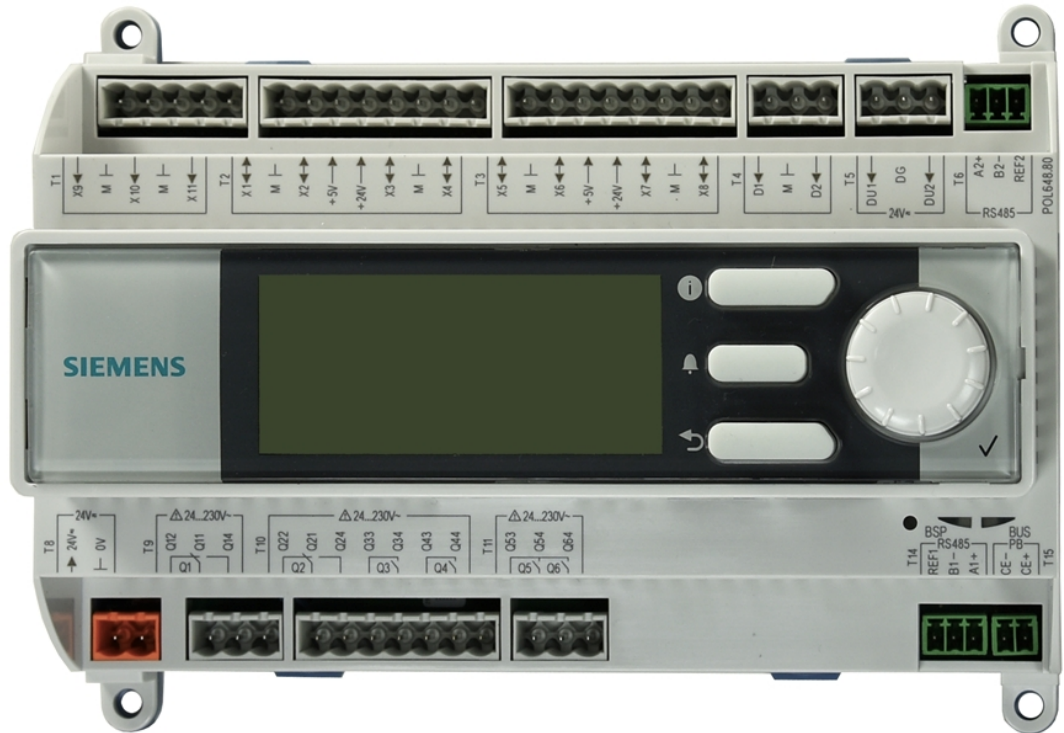

POL688 - 27 inputs and outputs

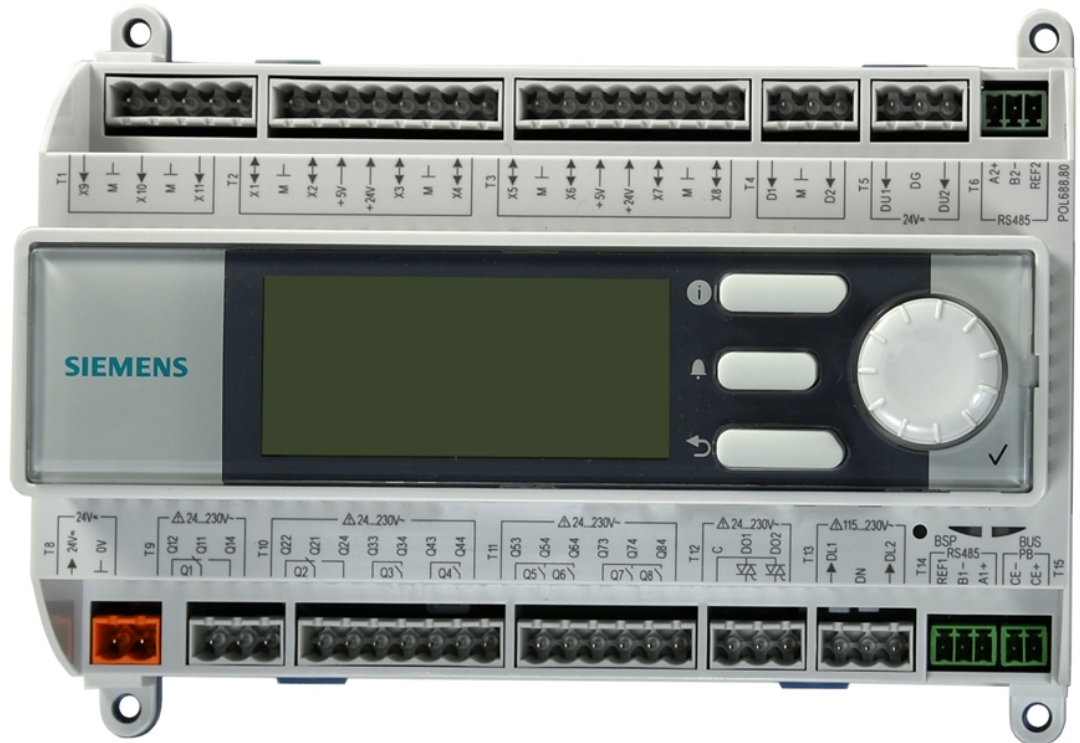

POL69x - 29 inputs and outputs

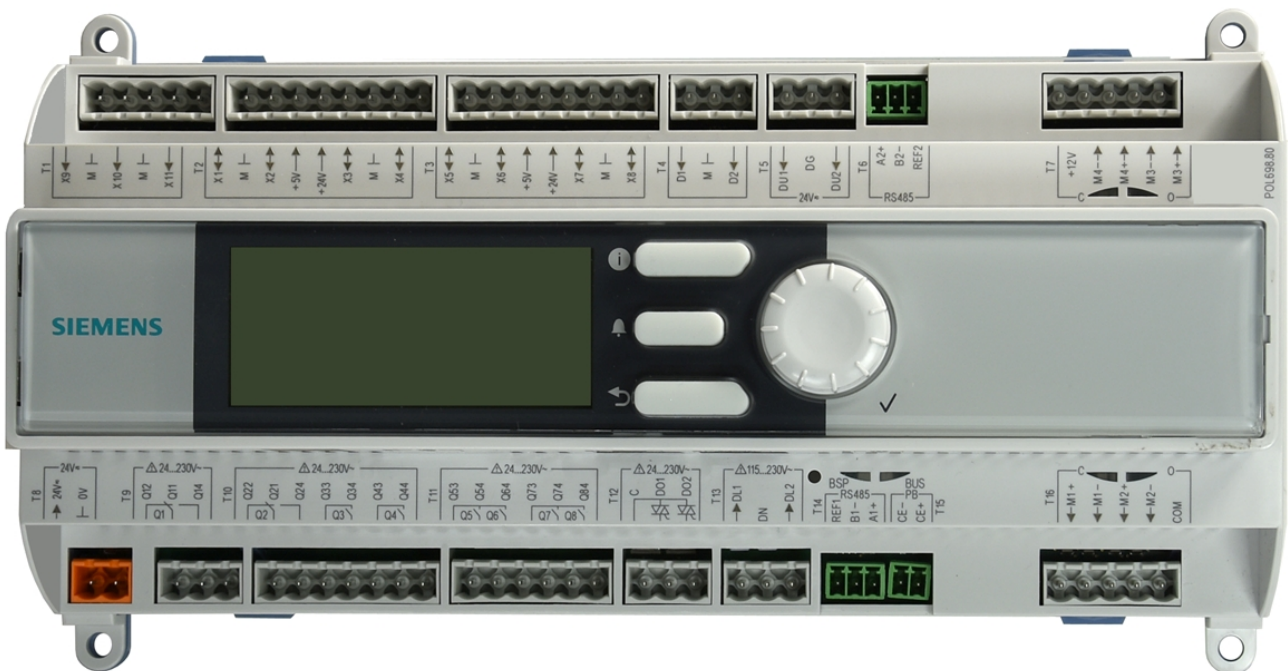

Additional interfaces on the bottom of the devices



Type	Stock number	Inputs	Outputs	HMI, integrated
POL648.10/STD	S55396-C481-A100	3 UI, 8 UIO, 4 DI	6 relays	
POL648.80/STD	S55396-C488-A100	3 UI, 8 UIO, 4 DI	6 relays	Yes
POL688.10/STD	S55396-C881-A100	3 UI, 8 UIO, 6 DI	8 relays, 2 triacs	
POL688.80/STD	S55396-C888-A100	3 UI, 8 UIO, 6 DI	8 relays, 2 triacs	Yes
POL698.10/STD	S55396-C981-A100	3 UI, 8 UIO, 6 DI	8 relays, 2 triacs, 2 stepper motors	
POL698.80/STD	S55396-C988-A100	3 UI, 8 UIO, 6 DI	8 relays, 2 triacs, 2 stepper motors	Yes
POL69U.10/STD	S55396-C991-A100	3 UI, 8 UIO, 6 DI	8 relays, 2 triacs, 2 stepper motors (UPS)	
POL69U.80/STD	S55396-C998-A400	3 UI, 8 UIO, 6 DI	8 relays, 2 triacs, 2 stepper motors (UPS)	Yes

POL648 - Input/output configuration

X9	X10	X11	X1	X2	X3	X4	X5	X6	X7	X8	D1	D2	DU1	DU2
N	N	N	N	N	N	N	N	N	N	N	DI	Dlp	DG	DG
Ni	Ni	Ni	Ni	Ni	Ni	Ni	Ni	Ni	Ni	Ni				
Pt	Pt	Pt	Pt	Pt	Pt	Pt	Pt	Pt	Pt	Pt				
DI	DI	DI	R	R	R	R	R	R	R	R				
			V in	V in	V in	V in	V in	V in	V in	V in				
			mA in	mA in	mA in	mA in	mA in	mA in	mA in	mA in				
			Dlx	Dlx	Dlx	Dlx	Dlx	Dlx	Dlx	Dlx				
			V out	V out	V out	V out	V out	V out	V out	V out				
			mA out	mA out			DV	DV	DV	DV				
							VM	VM						
DS		DS	DO	DO		DO	DO							
Q1		Q2	Q3	Q4		Q5	Q6							

POL688 - Input/output configuration

X9	X10	X11	X1	X2	X3	X4	X5	X6	X7	X8	D1	D2	DU1	DU2	
N	N	N	N	N	N	N	N	N	N	N	DI	Dlp	DG	DG	
Ni	Ni	Ni	Ni	Ni	Ni	Ni	Ni	Ni	Ni	Ni					
Pt	Pt	Pt	Pt	Pt	Pt	Pt	Pt	Pt	Pt	Pt					
DI	DI	DI	R	R	R	R	R	R	R	R					
			V in	V in	V in	V in	V in	V in	V in	V in					
			mA in	mA in	mA in	mA in	mA in	mA in	mA in	mA in					
			Dlx	Dlx	Dlx	Dlx	Dlx	Dlx	Dlx	Dlx					
			V out	V out	V out	V out	V out	V out	V out	V out					
			mA out	mA out			DV	DV	DV	DV					
							VM	VM							
DS		DS	DO	DO		DO	DO	DO	DO		DT	DT		DA	DA
Q1		Q2	Q3	Q4		Q5	Q6	Q7	Q8		DO1	DO2		DL1	DL2

POL69x Input/output configuration

X9	X10	X11		X1	X2	X3	X4	X5	X6	X7	X8		D1	D2	DU1	DU2		M4/3
N	N	N		N	N	N	N	N	N	N	N		DI	Dlp	DG	DG		SMv
Ni	Ni	Ni		Ni	Ni	Ni	Ni	Ni	Ni	Ni	Ni							
Pt	Pt	Pt		Pt	Pt	Pt	Pt	Pt	Pt	Pt	Pt							
DI	DI	DI		R	R	R	R	R	R	R	R							
				V in	V in	V in	V in	V in	V in	V in	V in							
				mA in	mA in	mA in	mA in	mA in	mA in	mA in	mA in							
				Dlx	Dlx	Dlx	Dlx	Dlx	Dlx	Dlx	Dlx							
				V out	V out	V out	V out	V out	V out	V out	V out							
				mA out	mA out			DV	DV	DV	DV							
								VM	VM									
DS		DS	DO	DO		DO	DO	DO	DO		DT	DT		DA	DA			SMc
Q1		Q2	Q3	Q4		Q5	Q6	Q7	Q8		DO1	DO2		DL1	DL2			M1/2

Key

Signal type	Short name	Description
Analog inputs	N	NTC10...100k
	Ni	Ni1000
	Pt	Pt1000
	R	0...2.5 kΩ
	V in	DC 0...10 V
	mA in	4...20 mA
Digital inputs	Dlx	Potential-free
	DI	Potential-free
	Dlp	Potential free, 300 Hz
	DG	Active, 24 V (AC/DC)
	DA	Active, AC 230 V
Analog outputs	V out	DC 0...10 V
	mA out	4...20 mA
	VM	PWM
Digital outputs	DV	DC 24 V
	DS	Relay, NO/NC
	DO	Relay, NO
	DT	Triac
Stepper motors	SMv	Voltage controlled, bipolar or unipolar
	SMc	Current controlled PWM, bipolar

Housing and weight

Housing

Color	<ul style="list-style-type: none"> • Base plate: Pigeon blue (RAL 5014) • Housing: Light gray (RAL 7035)
Dimensions	See "Dimensions [→ 30]"

Weight

Type	Weight
POL648.10/xxx	453 g
POL648.80/ xxx	492 g
POL688.10/ xxx	468 g
POL688.80/ xxx	506 g
POL698.10/ xxx	552 g
POL698.80/ xxx	593 g
POL69U.10/ xxx	611 g
POL69U.80/ xxx	652 g
Packaging for POL69x	119 g
Packaging POL648 and POL688	95 g

Battery compartment for back-up battery

Permissible battery type: BR2032

Processor and memory

Processor

Main processor	Cortex M4 NXP LPC4337JET256 (136 kB RAM, 1 MB Flash)
Subprocessor	Cortex M3 NXP LPC1763FBD100 (64 kB RAM, 256 kB Flash)

Storage

SDRAM	64 MB
Flash	64 MB

Power data

Power, T8	
Operating voltage POL648, POL688 POL698, POL69U	AC 24 V -20%...+20%; DC 24 V \pm 10% AC 24 V -15%...+20%; DC 24 V \pm 10%
Frequency	45...65 Hz
Protection class	III (SELV / PELV) UL Class 2
External fuse in the supply line	max. 4 A non-renewable fuse or circuit breaker, type B, C or D
Power consumption, without connected extension modules POL648, POL688 POL698, POL69U	39 VA / 24 W 60 VA / 43 W
Current consumption AC, without extension modules POL648, POL688 POL698, POL69U	max. 1.6 A @ AC 24 V max. 2.5 A @ AC 24 V
Current consumption DC, without extension modules POL648, POL688 POL698, POL69U	max. 1.0 A @ AC 24 V max. 1.8 A @ AC 24 V
Current consumption AC, for extension modules* POL648, POL688 POL698, POL69U	max. 2.4 A @ AC 24 V max. 1.5 A @ AC 24 V
Current consumption DC, for extension modules* POL648, POL688 POL698, POL69U	max. 3.0 A @ DC 24 V max. 2.2 A @ DC 24 V

* For calculation, see Q3900

Inputs/outputs

Universal inputs (T1)			
Analog inputs X9, X10, X11			
Typical sensor	Range	Resolution	Accuracy
NTC10k / NTC100k	500 Ω...670 kΩ	< 43 Ω @ 10 kΩ < 856 Ω @ 100 kΩ	± 215 Ω @ 10 kΩ ± 2996 Ω @ 100 kΩ
Ni1000 / Pt1000	740 Ω...2000 Ω	< 560 mΩ @ 1100 Ω	± 2250 mΩ @ 1100 Ω

Universal inputs (T1)	
Digital inputs X9, X10, X11	
0/1 digital signal (binary)	For potential-free inputs
Sensing voltage/current	Typical DC 18 V / 7 mA
Contact resistance	Max. 200 Ω (closed) Min. 50 kΩ (open)

Universal I/Os (T2, T3)			
Analog inputs X1...X8			
Type	Range	Resolution	Accuracy
NTC10k (@ 10 kΩ)	100 Ω...760 kΩ	< 43 Ω	± 215 Ω
NTC100k (@ 100 kΩ)	100 Ω...1280 kΩ	< 437 Ω	± 2166 Ω
Ni1000 (@ 1100 Ω)	100 Ω...3800 Ω	< 396 mΩ	± 1980 mΩ
Pt1000 (@ 1100 Ω)	100 Ω...3800 Ω	< 378 mΩ	± 1890 mΩ
Resistance input	0 Ω...2500 Ω	< 1000 mΩ	< 4000 mΩ
Input DC 0...5 V, ratiometric sensor	0...5 V	< 1 mV	< 25 mV @ 5 V
	Input resistance: > 100 kΩ		
Input DC 0...10 V	0...10 V	< 1 mV	< 50 mV @ 10 V
	Input resistance: > 100 kΩ		
Input 0...20 mA	0...20 mA	< 1 μA	< 120 μA @ 20 mA
	Input resistance: < 500 Ω		

Universal I/Os (T2, T3)	
Digital inputs X1...X8	
0/1 digital signal (binary)	For potential-free inputs
Sensing voltage/current	Typical DC 24 V / 6 mA
Contact resistance	Max. 200 Ω (closed) Min. 50 kΩ (open)

Universal I/Os (T2, T3)			
Analog outputs X1...X8			
Type	Range	Resolution	Accuracy
Output DC 0...10 V	0...10 V	< 11 mV	< 124 mV @ 10 V
Output current: Max. 1 mA (short-circuit proof) Capacitive load: < 200 nF			

Universal I/Os (T2, T3)			
Analog outputs X1, X2			
Type	Range	Resolution	Accuracy
Output 0...20 mA	0...20 mA	< 22 μA	< 243 μA @ 20 mA
Input resistance: < 500 Ω			

Universal I/Os (T2, T3)	
DC outputs, e.g. for relay control X5...X8	
Switching voltage	Typical DC 24 V
Switching current	Max. 25 mA

Universal I/Os (T2, T3)	
PWM outputs X5, X6	
Output voltage (high)	DC 8...12 V
Output voltage (low)	DC 0...1 V
Output current	Max. 10 mA
PWM frequency	0.5...2.5 kHz NOTICE! Default settings is 500 Hz
Sampling ratio	0...100 %
Resolution	0.5 %



NOTICE

The following applies to all inputs or inputs/outputs (X1...X11):

- Can be configured via software
- System zero ⊥ is the reference potential
- Maximum contact voltage: DC 24 V
- Overvoltage protection: Up to 40 V
- Resolution and accuracy are indicated at 25 °C ambient temperature.

Supply power for active / ratiometric sensors with 5 V, 24 V, 2 x 2 outputs (T2, T3)	
Sensor power output for active sensors	
Output voltage	DC 24 V (-25 %...15 %)
Output current	Max. 2 x 40 mA (short-circuit proof)
Reference potential	System zero \perp
Reference voltage output for ratiometric measurements NOTICE! Not designed for sensors with pulse-like energy demand.	
Output voltage	DC 5 V (± 2.5 %)
Output current	Max. 2 x 20 mA (short-circuit proof)

Digital inputs (T4)		
Digital inputs, potential-free D1, D2		
	D1	D2
0/1 digital signal (binary)	For potential-free contacts	<ul style="list-style-type: none"> For potential-free contacts or pulse measurements Configurable with firmware
Sensing voltage/ current	DC 24 V / 8 mA	
Contact resistance	<ul style="list-style-type: none"> Max. 200 Ω (closed) Min. 50 kΩ (open) 	
Pulse frequency	Max. 60 Hz	Max. 60 Hz
Pulse measurement		Max. 18,000 pulses/min.

Digital inputs (T5)	
24 V active digital inputs DU1, DU2	
0/1 digital signal (binary)	Galvanically separated voltage input
Nominal voltage	AC 24 V (-20 %...+20 %) DC 24 V (± 10 %)
Input current	8 mA @ DC 24 V
Pulse frequency	Max. 5 Hz

Digital inputs (T13)	
115...230 V active digital inputs DL1, DL2	
0/1 digital signal (binary)	Galvanically separated voltage input
Nominal voltage	AC 115 V...230 V (-15 %...+10 %)
Input current	< 1 mA @ 230 VAC
Frequency range	45...65 Hz
Pulse frequency	Max. 5 Hz
Dielectric strength: Insulation on low voltage	2900 V

Outputs

Relay outputs T9...T11	
Q1, Q2 (T9, T10) and Q3...Q8 (T10, T11)	
Relay: Type, contact	<ul style="list-style-type: none"> • Q1, Q2, monostable, NO/NC • Q3...Q8, monostable, NO
Switching voltage	<ul style="list-style-type: none"> • AC 12 V...250 V (45...65 Hz) • DC 12 V...30 V
Nominal current (resistive)	Max. AC 4 A / DC 3 A
Nominal current (inductive)	Max. 3 A (cos ϕ 0.6)
Maximum switch-on current	10 A (for \leq 1 sec)
Minimum current	10 mA @ AC/DC 12 V 1 mA @ AC 230 V
Contact life	Switchings: 100,000 @ 4 A resistive
	50,000 @ 300 mA resistive
	100,000 @ 2 A inductive
Dielectric strength: Insulation on low voltage	2900 V
External fuse supply line	max. 6.3 A non-renewable fuse or circuit breaker, type B, C or D

Triac outputs (T12)	
DO1, DO2	
Switching voltage	AC 19...250 V
Switching current (resistive)	Max. 500 mA / Min. 30 mA
Maximum switch-on current	1.5 A (for \leq 1 sec)
Cos Phi	1...0.8
Dielectric strength: Insulation on low voltage	2900 V
External fuse supply line	max. 2.0 A non-renewable fuse or circuit breaker, type B, C or D

	NOTICE
	<p>The following applies for relay and triac outputs:</p> <ul style="list-style-type: none"> • Do not mix SELV / PELV and mains power on the same terminal block. • Use external protection circuits for inductive loads. • The outputs are not fused internally. An external fuse is required.

Stepper motor control		
	SMc (T16)	SMv (T7)
Principle	Current controlled PWM	Voltage controlled
Uni/bipolar	Bipolar	Unipolar or bipolar mode can be configured over software
Modes	Half or full step mode can be configured over software	
LED displays	Two green LEDs indicate movement and state of the stepper motor control	
Switching capacity	Max. 7.2 W	Max. 9 W
Overall switching power	Max. 12 W	
Output voltage	Max. DC 24 V	Max. DC 12 V
Output current	Max. 600 mA	Max. 375 mA
Peak current	Max. 800 mA	Max. 550 mA
Overcurrent protection	n/A	> 0.8...2 A
Speed	0...500 steps/half steps per second	
Thermal warning	150 °C...180 °C	120 °C...170 °C
Capacitive load	Max. 2 nF	
Line length	Max. 10 m	
Uninterruptible power supply: UPS (POL69U only)	<ul style="list-style-type: none"> • Energy cells: > 140 Ws • Charge time: < 180 s • The EEV failsafe behavior can be set over software 	
Protection	<ul style="list-style-type: none"> • Overcurrent • Overtemperature • Undervoltage 	<ul style="list-style-type: none"> • Overcurrent • Overtemperature • Under and overvoltage
Notice	The outputs are not protected against incorrect 24 V wiring	

Interfaces



The device interfaces are depicted in "Design [→ 3]".

Interface	Symbol/ Location	Use	Technical data
Service/tool interface	T-SV	Engineering and commissioning <ul style="list-style-type: none"> SAPRO and SCOPE tool 	<ul style="list-style-type: none"> USB 2.0 device Plug: Type Micro-B Data rate: 1.5 Mbps and 12 Mbps. Off-the-shelf USB cable (not included) NOTICE! No galvanic separation to ground.
USB host	T-SP	Auxiliary energy via USB <ul style="list-style-type: none"> Supply of USB powered WLAN routers 	<ul style="list-style-type: none"> Plug: Type A Provides supply current of max. 500 mA NOTICE! No galvanic separation to ground. NOTICE! The interface currently does not provide communications.
SD card	left, from top	Loading and archiving <ul style="list-style-type: none"> Load application programs Download the firmware See SCOPE online help 	<ul style="list-style-type: none"> Cards: SD, SDHC Memory card size: 128 MB up to 32 GB File system: FAT16, FAT32 CAUTION! Switching off the controller during a read/write action may result in a loss of data.
HMI interface	T-HI	Commissioning and operation <ul style="list-style-type: none"> Climatix HMIs 	<ul style="list-style-type: none"> Plug: RJ45, screened Communication: RS485 (Modbus) Power: 24 V, max. 100 mA Compatible cables are included with the HMIs
Ethernet	T-IP	Engineering and commissioning <ul style="list-style-type: none"> SAPRO and SCOPE tool Cloud services <ul style="list-style-type: none"> Climatix IC integration Integration <ul style="list-style-type: none"> Modbus, BACnet IP or OPC Touch panels <ul style="list-style-type: none"> via Modbus IP or IP 	<ul style="list-style-type: none"> Plug: RJ45, screened Interface type: 10Base-T and 100BASE-TX, IEEE 802.3 compatible Bitrates: 10/100 Mbps Auto sensing Multiple, simultaneous connections are possible when using a switch
Process bus	T15	Process bus <ul style="list-style-type: none"> Connection of CLIMATIX controllers and room units KNX-LTE, PL-Link 	<ul style="list-style-type: none"> Type: KNX TP1, galvanic isolation. Baud rate: 9.6 kbps Bus power: 50 mA Bus load: 5mA Short-circuit proof

Interface	Symbol/ Location	Use	Technical data
Third-party bus	T6, T14	Connect field devices <ul style="list-style-type: none"> e.g. variable speed drive, fan coil controller Touch panels <ul style="list-style-type: none"> via RS485 Building automation system <ul style="list-style-type: none"> Modbus RTU BACnet MS/TP (T6 only) 	<ul style="list-style-type: none"> Plug: 3-pin connection for all interfaces RS-485 (EIA-485) interface Galvanically separated (T6 only) Data rate: max. 9.6...115 kBaud (can be set over software) Maximum connectable devices: Up to 31 devices Bus termination (can be set over software): 120 Ω + 1 nF (T6 only) Bus polarization (can be set over software): 680 Ω / 680 Ω NOTICE! The baud rate must be adapted to match the cable length.
Peripheral bus	Right side	Extension inputs/outputs <ul style="list-style-type: none"> Connection of I/O modules 	<ul style="list-style-type: none"> Plug connection (see "Accessory [→ 21]") Maximum number of I/O modules: 31 Addresses 1...31, 0 not used Please note "Power data [→ 9]". NOTICE! Not internally fused. Use an external fuse at 4 A in the power supply line.
Communication interface	Left side	Extending communications and integration <ul style="list-style-type: none"> Connect communication modules 	<ul style="list-style-type: none"> Plug connection (see "Accessory [→ 21]") Maximum number of communication modules: 2 Voltage / current: DC 5 V / max. 670 mA Short-circuit proof

Wire lengths

Interface	Wire lengths
Ethernet	Max. 100 m
Process bus	<ul style="list-style-type: none"> Overall length: Max. 1,000 m Between 2 nodes: max. 700 m (as per KNX specification)
Peripheral bus	<ul style="list-style-type: none"> Overall length: Max. 30 m Voltage drop off on 0 V wire: ≤ 1.5 V
Third-party bus	<ul style="list-style-type: none"> Overall length: Max. 1,000 m @ 9.6kBaud Max. 500 m @ 9.6kBaud between 2 nodes Total 40 m stub lines; 1 stub line max. 20 m
Service interface	Max. 3 m
Signal wiring	Max. 80 m NOTICE! Restriction: X9...X11 on NTC10k, NTC100k: max. 30 m

Cable types

Interface	Specification
Ethernet	Always screened: <ul style="list-style-type: none"> • 100Base-TX, cable category 5 • 10Base-T, cable category 4
Process bus	Shielded, twisted pair: 0.5...1.5 mm ² (as per KNX specification)
Peripheral bus	4-wire (2 wires as twisted pair), shielded, if >3 m
Third-party bus	2 or 3-wire, twisted, shielded, if >3 m
Signal lines (Inputs/outputs)	<ul style="list-style-type: none"> • Wire: 0.5...2.5 mm² • Stranded wire (twisted, terminating sleeves required): 0.5...1.5 mm² • Stripping lengths: <ul style="list-style-type: none"> – 7 mm for screw terminals (MVSTBW) – 10 mm for spring cage terminals (FKCT)

!	NOTICE
	Installation of connections as per: <ul style="list-style-type: none"> • Load • Local regulations • Applicable installation documents

Conformity

Ambient conditions and protection classification	
Classification as per EN 60730 Operation of automatic controller	Type 1
Degree of pollution	2
Overvoltage category	III
Design type	Device suited for use with equipment of safety classes I and II
Degree of protection of housing to EN 60529	IP20
Climatic ambient conditions Transport (in transport packaging) as per EN 60721-3-2	Class 2K3 <ul style="list-style-type: none"> • Temperature -25...70 °C • Air humidity: 5...90 % (non-condensing)
Operation per EN 60721-3-3	Class 3K7 <ul style="list-style-type: none"> • Average ambient temperature: ≤ 45 °C • Temperature: <ul style="list-style-type: none"> – POL6x8: -40...70 °C – POL69U: -40°C...60 °C • Air humidity: 5...90 % (non-condensing) • Air pressure: Minimal 700 hPa (corresponds to a maximum 3000 m above sea level)
Restrictions: Temperature range	<ul style="list-style-type: none"> • POL6x8 with 1 communication module: -40 °C...65 °C • POL6x8 with 2 communication modules: -40 °C...60 °C • LCD reliability range: -20 °C...60 °C • Process bus reliability range: -25 °C...70 °C
Mechanical ambient conditions Transport to EN 60721-3-2	Class 2M2
Operation per EN 60721-3-3	Class 3M2 NOTICE! Screw fix the devices if continuously exposed to resonance frequency. NOTICE! Comply as well with the Mounting Instructions "A6V10990056".

Standards, directives and approvals	
Product standard	EN 60730-1 Automatic electronic controls for household and similar use
Electromagnetic compatibility	For residential, commercial, and industrial environments
EU conformity (CE)	
RCM conformity	
UL Approbation Federal Communications Commission	UL916, UL873. http://database.ul.com FCC CFR 47 Part 15 Class B
CSA-Approbation	C22.2
EAC	
RoHS-China	
Environmental compatibility	The product environmental declaration () contains data on environmentally compatible product design and assessments (RoHS compliance, materials composition, packaging, environmental benefit, disposal).

LED indicators "BSP" and "BUS"

LED	Color	Flash response	Function
BSP	Red/green	Changes at 1 Hz	Software update mode: Download application or new firmware
	Green	Continuous	Application loaded and operational
	Orange	Continuous	Application loaded but not operational
	Orange	Flashing, 50 ms on / 1000 ms off	Application not loaded
	Red	Flashing at 2 Hz	Firmware error
	Red	Continuous	Hardware fault
BUS	The application sets the response and function. Additional notes are available in the SAPRO online help.		

LED indicators (green) "O" and "C" for stepper motor control

LED "O" (open)	LED "C" (close)	Status
Off	Off	Valve is not moving
On	Off	Valve is fully open (if referenced*)
Off	On	Valve is fully closed (if referenced*)
Off	Flashing, 250 ms on / 250 ms off	Valve is closing
Flashing, 250 ms on / 250 ms off	Off	Valve is opening
Off	Flashing, 50 ms on / 450 ms off	Valve moving to the close-failsafe position
Flashing, 50 ms on / 450 ms off	Off	Valve moving to the open-failsafe position
Flashing, 250 ms on / 250 ms off	Flashing, 250 ms on / 250 ms off	Error

* "If referenced" means a reference deployment was made. So that the program knows the position of the valve

Download button

Along with an SD card, the download button provides a simple and fast method for loading firmware and application files to the controller without additional tools.



Additional information on the download button is available in the SCOPE tool online help.

Integrated HMI (for ".80" controller types)

See "Design [→ 3]".

An integrated HMI provides the following operating elements:

- Turn/press button
- Alarm button
- Info button
- ESC button

The LCD has blue background lighting.

Real-time clock

- Backup without battery: 3 days
- Backup with battery: 4 years



The Mounting and installation instructions (A6V10990056) illustrate how to install or replace the backup batteries for the real-time clock.

Data Matrix Code (DMC)

The controller has a Data Matrix Code (DMC).

You can scan the code using a code reader app. The result is a text string that, for example, can be helpful on service calls. Example:

1PS55396-C488-A100+31PPOL648.80/STD+S160908Z0000000005+23S00-A0-03-EB-01-04+3C3WSZHI-2J7SM-ETMN7-I3LO4-VDVNX

The text string is subdivided into code letters:

- 1P: Siemens stock number (SSN); fixed
- 31P: Siemens device type (ASN); fixed
- S: Date (YYMMDD), series, serial number, variable
- 23S: MAC address (hex); variable
- 3C: Climatix IC activation code (password); variable

Climatix controllers

Type	Stock number	Description
POL648.10/STD	S55396-C481-A100	Climatix C600 controller
POL648.80/STD	S55396-C488-A100	Climatix C600 controller with HMI
POL688.10/STD	S55396-C881-A100	Climatix C600 controller
POL688.80/STD	S55396-C888-A100	Climatix C600 controller with HMI
POL698.10/STD	S55396-C981-A100	Climatix C600 controller with EEV drivers
POL698.80/STD	S55396-C988-A100	Climatix C600 controller with HMI, EEV drivers
POL69U.10/STD	S55396-C991-A100	Climatix C600 controller with EEV drivers, UPS (failsafe)
POL69U.80/STD	S55396-C998-A400	Climatix C600 controller with HMI, EEV drivers, UPS (failsafe)

Accessory

Siemens accessories

Type	Stock number	Designation
POL064.85/STD		Terminal set POL648, screw connection
POL064.86/STD		Terminal set POL648, spring return
POL068.85/STD		Terminal set POL688, screw connection
POL068.86/STD		Terminal set POL688, spring return
POL069.85/STD		Terminal set POL69x, screw connection
POL069.86/STD		Terminal set POL69x, spring return

PHOENIX CONTACT accessories, www.phoenixcontact.com

Phoenix cable connector

Phoenix type	Description
ZEC 1,0/ 4-LPV-3,5 GY35AUC2C11	Printed circuit board connector, Board-to-Board to connect I/O modules
ZEC 1,0/ 4-ST-3,5 GY35AUC1R1,4	Printed circuit board connector, Board-to-Board to connect I/O modules
ZEC 1,0/10-LPV-3,5 GY35AUC2C11	Printed circuit board connector, Board-to-Board for connecting COM modules

Phoenix terminal plug

The following overview of compatible types assist you in selecting and ordering the Phoenix type:

Controller connectors	Compatible Phoenix connector types	Color
T1	1 x 5 pos - MVSTBW, FKCVW or FKCT 2,5/3-ST	Gray
T2	1 x 8 pos - MVSTBW, FKCVW or FKCT 2,5/8-ST	Gray
T3	1 x 8 pos - MVSTBW, FKCVW or FKCT 2,5/8-ST	Gray
T4	1 x 3 pos - MVSTBW, FKCVW or FKCT 2,5/3-ST	Gray
T5	1 x 3 pos - MVSTBW, FKCVW or FKCT 2,5/3-ST	Gray
T6	1 x 3 pos - MCVW 1.5/ 3-ST-3,5	Green
T7	1 x 5 pos - MVSTBW, FKCVW or FKCT 2,5/5-ST	Gray
T8	1 x 2 pos - MVSTBW, FKCVW or FKCT 2,5/2-ST	Orange
T9	1 x 3 pos - MVSTBW, FKCVW or FKCT 2,5/3-ST	Gray
T10	1 x 7 pos - MVSTBW, FKCVW or FKCT 2,5/7-ST	Gray
T11	1 x 6 pos - MVSTBW, FKCVW or FKCT 2,5/6-ST	Gray
T12	1 x 3 pos - MVSTBW, FKCVW or FKCT 2,5/3-ST	Gray
T13	1 x 3 pos - MVSTBW, FKCVW or FKCT 2,5/3-ST	Gray
T14	1 x 3 pos - MCVW 1.5/ 3-ST-3,5	Green
T15	1 x 2 pos - MCVW 1.5/ 2-ST-3,5	Green
T16	1 x 5 pos - MVSTBW, FKCVW or FKCT 2,5/5-ST	Gray

Product documentation

Document ID	Title	Description
A6V10990076	Datasheet C600 Climatix controller	Functions, use, technical data, terminal concept, and dimensions for the C600 controller product range
A6V10990056	Installation C600 Climatix controller	Mounting and wiring the Climatix controller
M3910	Climatic mounting instructions	Connecting extension modules. Power variants.
Q3900en	Climatix range	The section "Connecting the extension modules" is important with sample calculations for permissible pass-through current
Q3993en	EMC design guidelines	Notes on EMC, especially for panel design

Notes

Safety: National regulations

	⚠ CAUTION
	National safety regulations Failure to comply with national safety regulations may result in personal injury and property damage. <ul style="list-style-type: none">• Observe national provisions and comply with the appropriate safety regulations.

Engineering: Panel

	⚠ WARNING
	Risk of electric shock caused by unintentional contact with electrical connections Touching powered connections (over 42 Volt) can result in serious injury. <ul style="list-style-type: none">• Install the device in a protective housing (preferably a panel).• A key or tool is required to open the protective housing.• AC 230 V cable must be double insulated versus safety extra-low voltage (SELV) cables.

Installation

	⚠ WARNING
	No internal line protection for supply lines to external consumers Risk of fire and injury due to short-circuits! <ul style="list-style-type: none">• Adapt the line diameters as per local regulations to the rated value of the installed fuse.



⚠ WARNING

Electric shock on plug-in terminal blocks

The distance to parts potentially under power is very small when using plug-in terminal blocks.

- Ensure the device is not connected to power before using plug-in terminals.

Disposal



The device is considered an electronics device for disposal in terms of European Directive 2012/19/EU and may not be disposed of as domestic garbage.

- Dispose of the device through channels provided for this purpose.
- Comply with all local and currently applicable laws and regulations.
- Dispose of empty batteries in designated collection points.

POL648.10, POL648.80

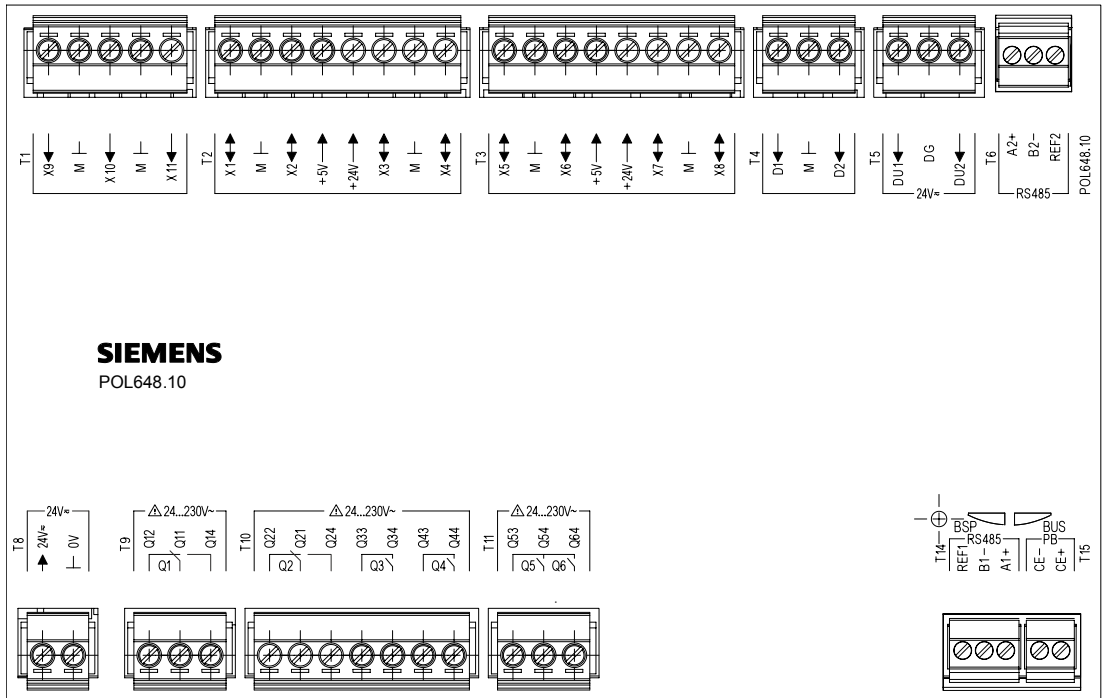

POL648.10

Slot	Terminal	Description
T1	X9, X10, X11	Universal inputs
	M	System zero
T2	X1, X2, X3, X4	Universal inputs/outputs
	M	System zero
	+5V	5V reference power
	+24V	24V sensor power
T3	X5, X6, X7, X8	Universal inputs/outputs
	M	System zero
	+5V	5V reference power
	+24V	24V sensor power
T4	D1, D2	Digital inputs (potential-free)
	M	System zero
T5	DU1, DU2	24 V active digital input
	DG	Reference potential 24V active digital input
T6	A2+, B2-, REF2	Third-party bus, RS-485 NOTICE! Galvanically separated
T8	24V=	Power AC 24V / DC 24V
	0V	System zero
T9	Q11	NO contact Q1 (normally closed)
	Q12	Wiring Q1
	Q14	NO contact Q1 (normally open)
T10	Q21	NO contact Q2 (normally closed)
	Q22	Wiring Q2
	Q24	NO contact Q2 (normally open)

Slot	Terminal	Description
	Q33	Wiring for Q3
	Q34	NO contact Q3 (normally open)
	Q43	Wiring Q4
	Q44	NO contact Q4 (normally open)
T11	Q53	Common wiring for Q5 and Q6
	Q54, Q64	NO contacts for Q5 and Q6 (normally open)
T14	A1+, B1-, REF1	Third-party bus, RS-485 NOTICE! Not galvanically separated
T15	CE-, CE+	Process bus (based on KNX TP1)

POL688.10, POL688.80

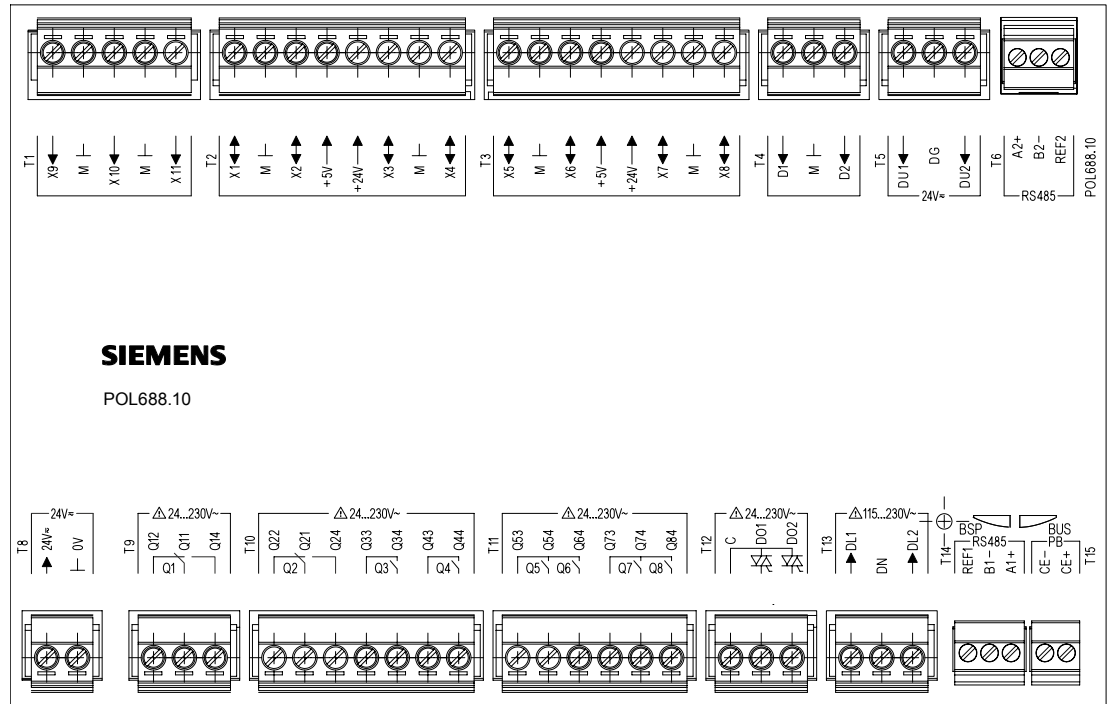

POL688.10

Slot	Terminal	Description
T1	X9, X10, X11	Universal inputs
	M	System zero
T2	X1, X2, X3, X4	Universal inputs/outputs
	M	System zero
	+5V	5V reference power
	+24V	24V sensor power
T3	X5, X6, X7, X8	Universal inputs/outputs
	M	System zero
	+5V	5V reference power
	+24V	24V sensor power
T4	D1, D2	Digital inputs (potential-free)
	M	System zero
T5	DU1, DU2	24 V active digital input
	DG	Reference potential 24V active digital input
T6	A2+, B2-, REF2	Third-party bus, RS-485 NOTICE! Galvanically separated
T8	24V=	Power AC 24V / DC 24V
	0V	System zero
T9	Q11	NO contact Q1 (normally closed)
	Q12	Wiring Q1
	Q14	NO contact Q1 (normally open)
T10	Q21	NO contact Q2 (normally closed)
	Q22	Wiring Q2
	Q24	NO contact Q2 (normally open)
	Q33	Wiring for Q3
	Q34	NO contact Q3 (normally open)

Slot	Terminal	Description
	Q43	Wiring Q4
	Q44	NO contact Q4 (normally open)
T11	Q53	Common wiring for Q5 and Q6
	Q54, Q64	NO contacts for Q5 and Q6 (normally open)
T12	C	Actuator voltage AC 24..230V
	DO1, DO2	Switching output 0.5A, triac
T13	DL1, DL2	115...230V active digital input
	DN	Reference potential 115...230V active digital input
T14	A1+, B1-, REF1	Third-party bus, RS-485 NOTICE! Not galvanically separated
T15	CE-, CE+	Process bus (based on KNX TP1)

POL698.10, POL69U.10, POL698.80, POL69U.80

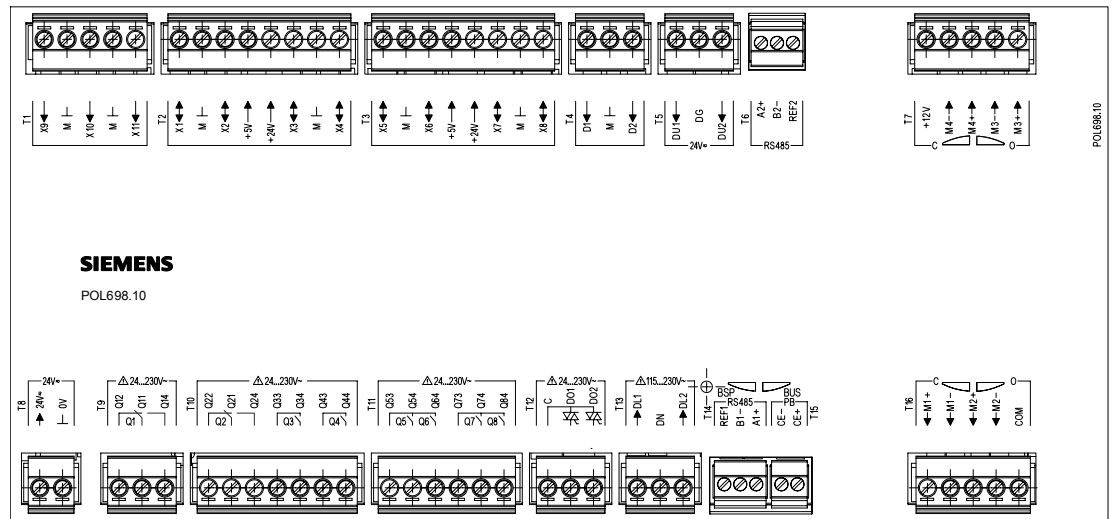

POL698.10 or POL69U.10

Slot	Terminal	Description	
T1	X9, X10, X11	Universal inputs	
	M	System zero	
T2	X1, X2, X3, X4	Universal inputs/outputs	
	M	System zero	
	+5V	5V reference power	
	+24V	24V sensor power	
T3	X5, X6, X7, X8	Universal inputs/outputs	
	M	System zero	
	+5V	5V reference power	
	+24V	24V sensor power	
T4	D1, D2	Digital inputs (potential-free)	
	M	System zero	
T5	DU1, DU2	24 V active digital input	
	DG	Reference potential 24V active digital input	
T6	A2+, B2-, REF2	Third-party bus (RS-485) NOTICE! Galvanically separated	
T7	+12V	Stepper motor control, M4/3 • Voltage controlled • unipolar / bipolar	
	M4-, M4+, M3-, M3+		
	Unipolar		Control of motor windings 0V
	Bipolar		Control of motor winding 0V/12V
T8	24V≈	Power AC 24V / DC 24V	
	0V	System zero	
T9	Q11	NO contact Q1 (normally closed)	
	Q12	Wiring Q1	
	Q14	NO contact Q1 (normally open)	
T10	Q21	NO contact Q2 (normally closed)	
	Q22	Wiring Q2	
	Q24	NO contact Q2 (normally open)	
	Q33	Wiring for Q3	
	Q34	NO contact Q3 (normally open)	

Slot	Terminal	Description	
	Q43	Wiring Q4	
	Q44	NO contact Q4 (normally open)	
T11	Q53	Common wiring for Q5 and Q6	
	Q54, Q64	NO contacts for Q5 and Q6 (normally open)	
	Q73	Common wiring for Q7 and Q8	
	Q74, Q84	NO contacts for Q7 and Q8 (normally open)	
T12	C	Actuator voltage AC 24...230V	
	DO1, DO2	Switching output 0.5A, triac	
T13	DL1, DL2	115...230V active digital input	
	DN	Reference potential 115...230V active digital input	
T14	A1+, B1-, REF1	Third-party bus, RS-485 NOTICE! Not galvanically separated	
T15	CE-, CE+	Process bus (based on KNX TP1)	
T16	COM	Not connected internally	Stepper motor control, M1/2 <ul style="list-style-type: none"> • Current controlled • bipolar
	M1-, M1+, M2-, M2+	Control of motor winding 0V/24V	

Dimensions

POL648 and POL688 (all dimensions in mm)

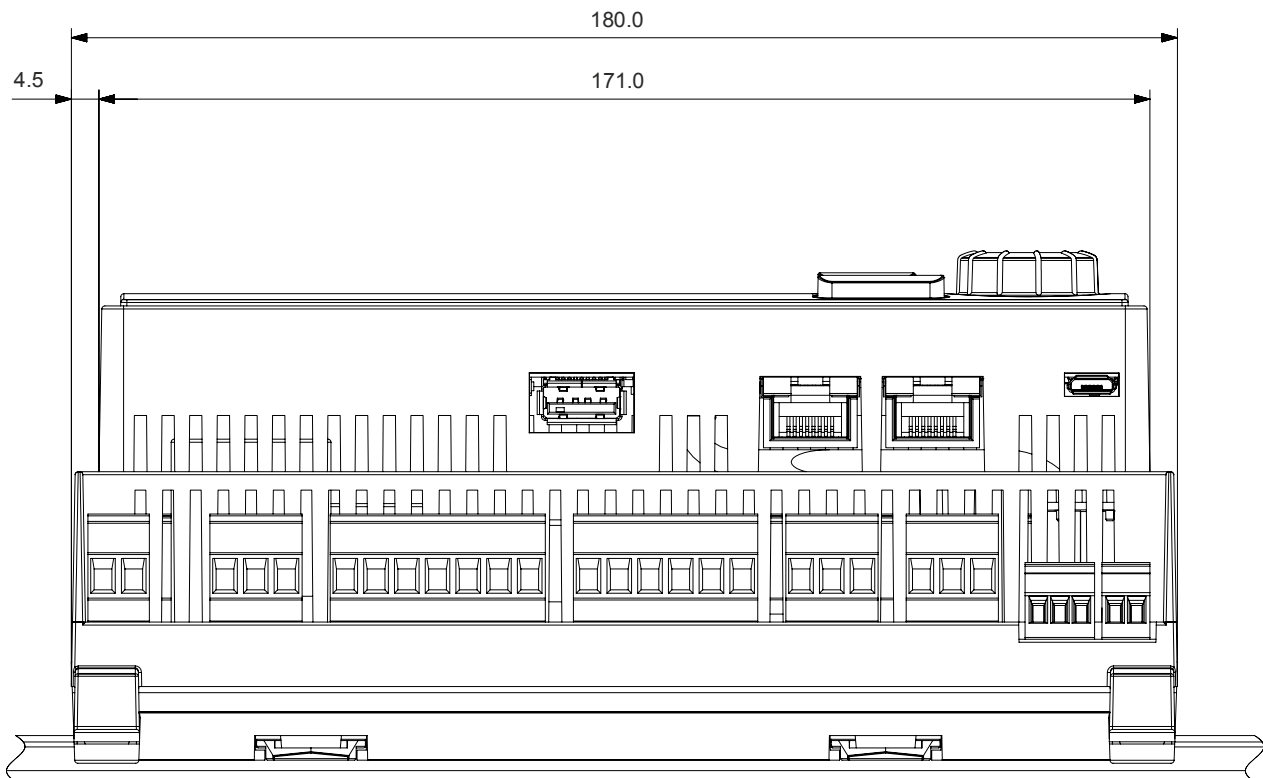

Bottom view POL648 and POL688 (POL688 depicted here)

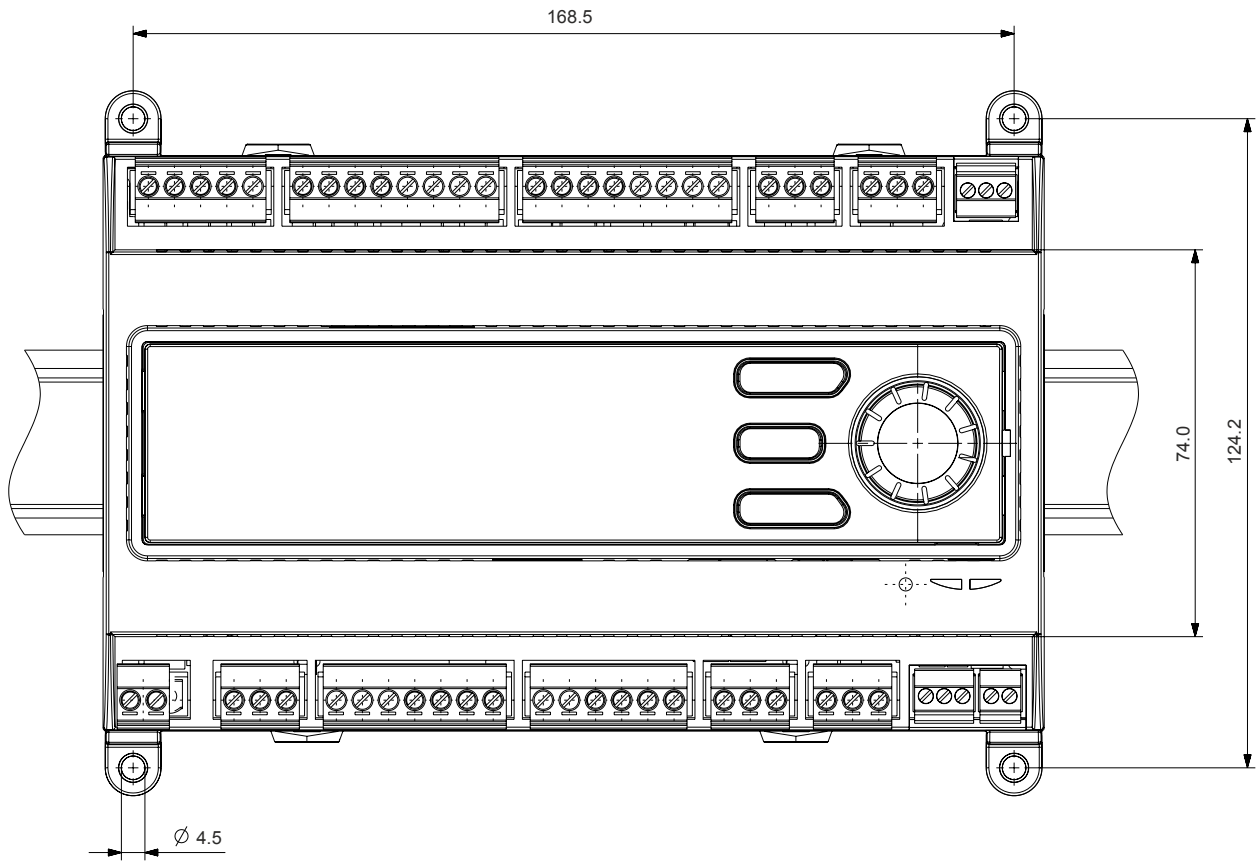

Front view POL648 and POL688 (POL688 depicted here)

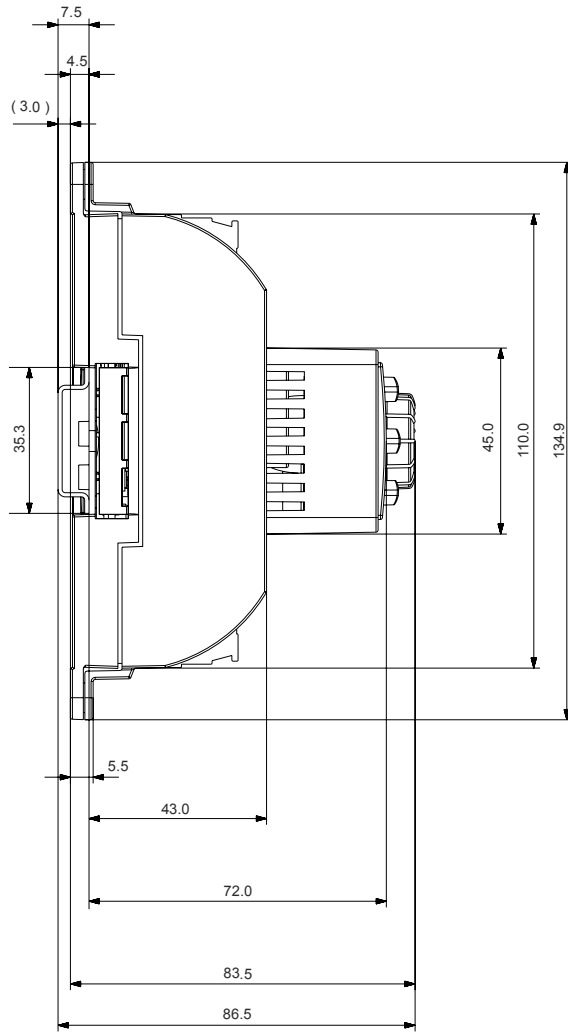

Side view POL648 and POL688

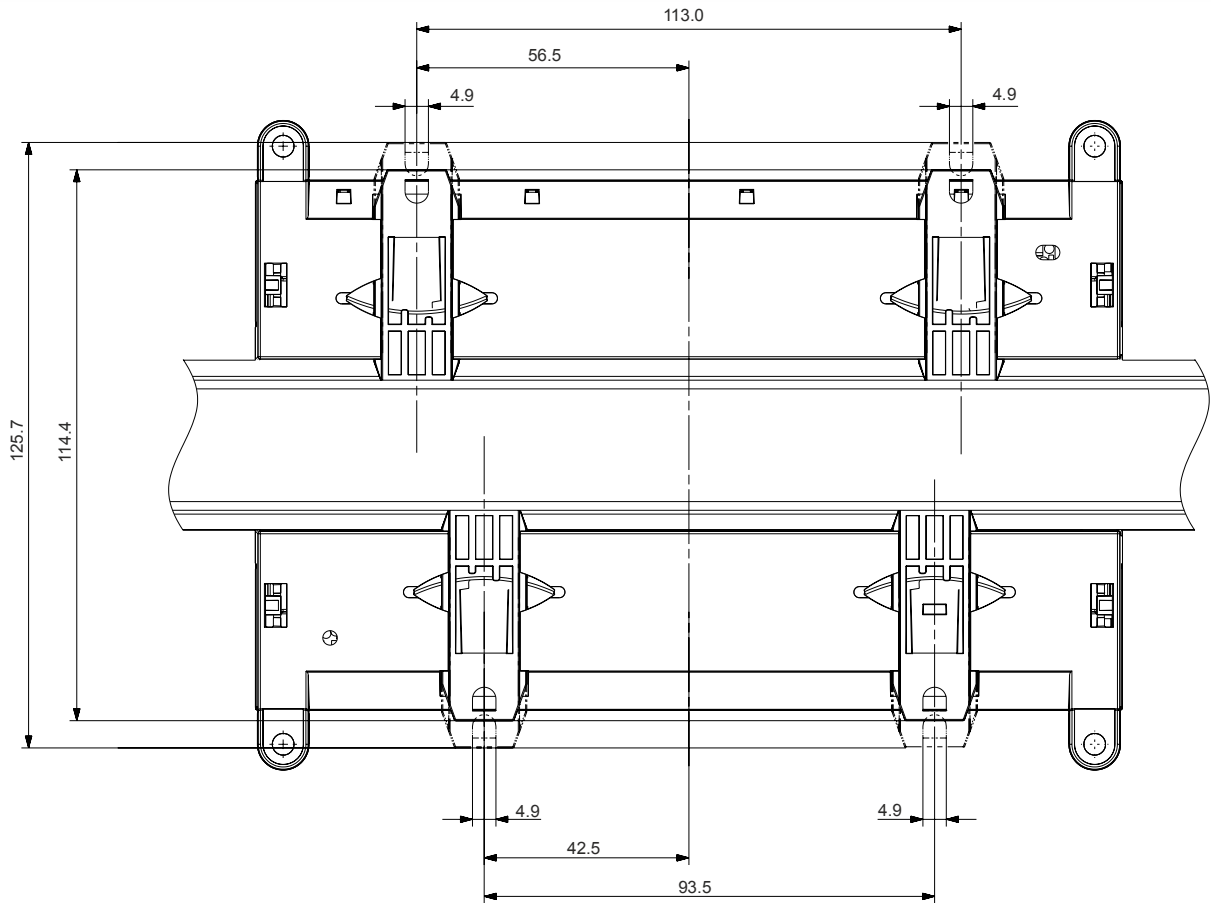

Rear view POL648 and POL688

POL698 and POL69U (all dimensions in mm)

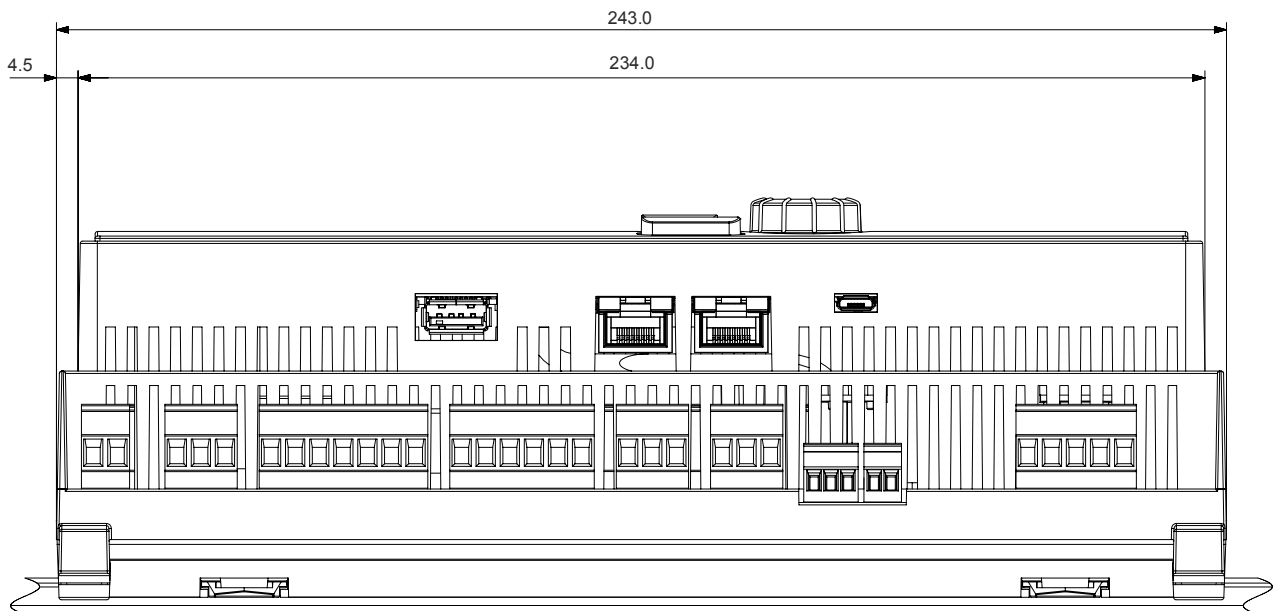

Bottom view POL698 and POL69U

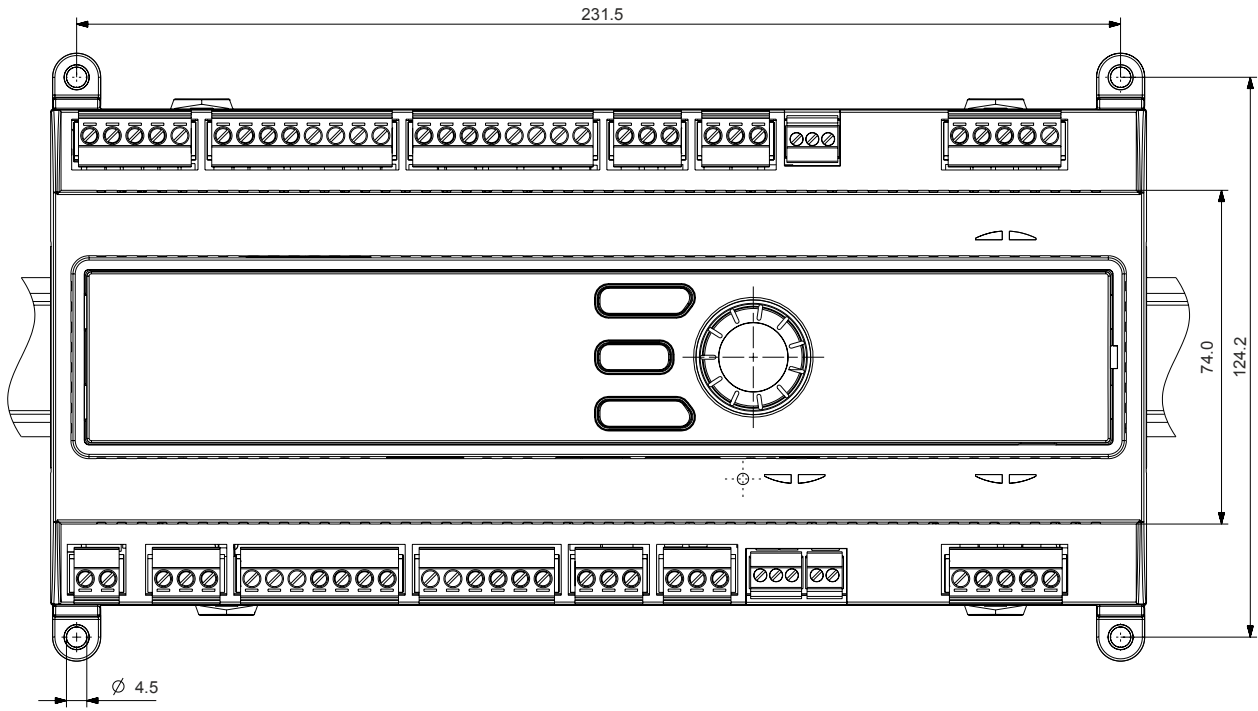

Front view POL698 and POL69U

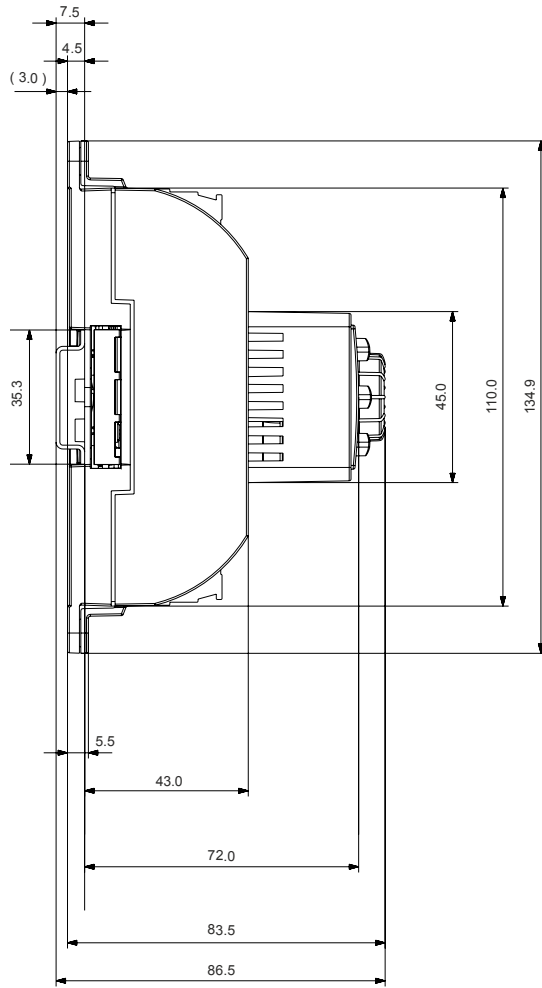

Side view POL698 and POL69U

